

# Tile Installation Manual Specification Guide 09 30 00

Published 2025



# PROFILE OF TTMAC

The Terrazzo, Tile and Marble Association of Canada was founded in 1944. Its mandate was to develop a method of standardizing terrazzo, tile and marble installation techniques, as well as being a technical resource and liaison for architects, specifiers, designers and engineers. TTMAC honours this commitment today as well as many other services and support of the hard surface industry and its members.

## ASSOCIATION ACTIVITIES & BENEFITS

- Produces and distributes specification guidelines.
- Sets standards for installation methods used in the industry.
- Promotes technical research, new materials and techniques.
- Maintains an up-to-date library resource centre.
- Encourages development of new technology and products.
- Is a door to the industry in Canada with a global outlook.
- Publishes newsletters, maintains and circulates an annual Membership Directory and Buyers Guide.
- Provides a liaison with other associations, government departments, trade magazines, trade commissions, and those interested in sharing information for the good of the industry.
- Offers independent arbitration of complaints and site inspections.
- Promotes an annual convention, seminars and workshops. Provides general information to architects, specifiers, engineers, contractors, designers and the building industry in general.
- Encourages and promotes the installation of terrazzo, tile marble, granite, slate and other dimensional stone products and related materials.
- Has full-time technical representative on staff.
- Assists in setting training standards and distributes information to further develop training in the hard surface industry.

## SPECIFICATION STUDY ON TILE

The Terrazzo, Tile and Marble Association of Canada provides this 2019-2021 Specification Guide 09 30 00 to assist in clarifying and standardizing installation specifications for hard surface material and related products.

It is the responsibility of the architect/specifier or qualified consultant to clearly specify in detail requirements for the complete installation of the hard surface materials, products, systems, related sections, warranty and guarantees.

This guide refers to the usual circumstances relating to tile installations. In the case of circumstances out of the ordinary, we suggest that you consult the TTMAC. The scope of work and methods of installation may vary by site conditions and from region to region.

Distribution of this document in its original published form is restricted. Reproduction for commercial or advertising purposes shall not be made without the permission of the Terrazzo, Tile and Marble Association of Canada.

The Terrazzo, Tile and Marble Association of Canada do not accept liability for the information presented by this document. Readers are expected to make judicious use of data in this guide as part of the quest to further their knowledge.



## TTMAC SPECIFICATIONS AND GUIDES

Life Cycle Guideline  
Tile Installation Manual 09 30 00  
Terrazzo Specification Guide 09 66 00  
Fabrication Manual

Terrazzo Colour Plates  
Hardsurface Maintenance Guide  
Dimensional Stone Guide  
Tile Installer's Technical Handbook

As the members of TTMAC are continually striving to maintain and improve the standards of the industry, specifications are subject to revision at any time.

Photo on cover: Intersecting Waves, Montreal, QC. Photo courtesy of Mapei Inc.

## ACKNOWLEDGEMENTS

Terrazzo, Tile and Marble Association of Canada appreciates the assistance of the following in the preparation of this guide:

### **TTMAC Board of Directors**

#### **Executive**

**President:**

Craig Wood – Apex Granite and Tile Ltd.

**Vice President:**

Sherril Wildman – Ardex Canada

**Secretary/Treasurer:**

Andrew Carniel – Bridgewater Tile Ltd.

**Past President:**

Tod Valickis – Schluter Systems Canada Inc.

**General Officer:**

Sylvie Dzikewich – Mapei

#### **Directors**

**Contractor Division:**

Steve Bordt – Apex Granite and Tile Inc.

Carlo Rao – Castlewall Marble and Tile

Nicola Capomasi – Thor and Partners

Andrew Carniel – Bridgewater Tile Ltd.

**Supplier Division**

John Alley – Custom Building Products

Pierre Hebert – Sika Canada

Barb Hilderman – Ames Tile

Badr R. Salhia - CIOT

Aneil Hussein – SHNIER/Division9

### **TTMAC SPECIFICATIONS & TECHNICAL RESEARCH COMMITTEE**

Dale Kempster – Chairperson – Schluter Systems Canada Inc.

Alexander Grams – Dialog Design

Bill Wright – Ardex Canada

Owen Huard – Huard-Duncan Group

John Alley – Custom Building Products

Derek Januszewski – Kiesel

Stefan Helmrich – Rudiger Group Inc

Johanne Racine – Ceragres

Pierre Hebert – Sika Canada

Alex Grams – Dialog Design

Paul Locicero – Mapei

Will White – Custom Building Products

**TTMAC General Manager:** Violeta Ivanescu

This 2025 Specification Guide 09 30 00 Tile Installation Manual has been completely overhauled to provide the user with a more orderly and concise document.

This manual has been created with reference to Master Format 2015 TM numbering and titling systems in conformance with Construction Specifications Canada recommended practice.

Changes are noted with a  in the margin.

### **ORGANIZATIONS**

American National Standards Institute (ANSI)  
American Society for Testing and Materials (ASTM)  
Canadian General Standards Board (CGSB)  
Canadian Standards Association (CSA)  
Construction Specifications Canada (CSC)  
Ceramic Tile Institute of America (CTIOA)  
International Standards Organization (ISO)

Natural Stone Institute of America (STIA)  
Materials and Methods Standards Association (MMSA)  
The National Terrazzo & Mosaic Association (NTMA)  
Tile Council of North America (TCNA)  
Terrazzo, Tile and Marble Guild of Ontario (TTMGO)  
Terrazzo, Tile & Marble Trade School Inc. (Ontario) (TTMTS)  
Trowel Trades Training Association (TTTA)

**This 09 30 00 2025 Guide supersedes 09 30 00 2019-2021**

## TABLE OF CONTENTS

|  |         |
|--|---------|
| Acknowledgements   | Page 2  |
| SUSTAINABILITY   | Page 6  |
| Notes for the Professional   | Page 7  |
| • Surface Preparation  | Page 7  |
| • Environmental Conditions   | Page 7  |
| • Site Conditions  | Page 7  |
| • Materials  | Page 7  |
| • Mock-ups   | Page 8  |
| • Execution  | Page 8  |
| • Recycling & Environmental Responsibilities                             | Page 9  |
| • Cleaning   | Page 9  |
| Successful Tile and Stone Projects Roles and Responsibilities            | Page 9  |
| Canadian Certified Tile Installer  | Page 11 |
| Concrete Chronicles Article  | Page 12 |
| Tile   | Page 16 |
| • Types  | Page 16 |
| • Ceramic Tile   | Page 16 |
| • Porcelain Tile   | Page 17 |
| • Thin Ceramic Tile Panels   | Page 17 |
| • Trims  | Page 18 |
| Ceramic Tile Notes for the Specifier                                     | Page 18 |
| • Selection  | Page 18 |
| • Stone Tile   | Page 19 |
| • Surface Finishes   | Page 19 |
| • Stone Tile Selection   | Page 20 |
| Stone Notes for the Specifier  | Page 20 |
| Other Considerations for Specifying Tile                                 | Page 20 |
| Installation Notes for the Specifier                                     | Page 21 |
| • Size Tolerances for Tile and Grout Joint Selection                     | Page 21 |
| • Tile lippage   | Page 21 |
| • Deflection   | Page 22 |
| • Exterior Tile Cladding   | Page 22 |
| • Exterior Tile Floors & Decks   | Page 23 |
| • Installation of Agglomerate Marble, Terrazzo, Tile & Dimensional Stone | Page 23 |
| Installation Materials   | Page 23 |
| • Setting Materials – Adhesives and Mortars                              | Page 23 |
| • Types of Installation Systems  | Page 24 |
| Spot Bonding   | Page 26 |
| • Introduction   | Page 26 |
| • The Issue  | Page 26 |
| • Industry Coverage Requirements   | Page 27 |
| Flat back-troweling & Notched Back-Troweling                             | Page 28 |
| Optical Hazing   | Page 29 |
| Grout Guide  | Page 30 |
| Trowel Recommendations   | Page 31 |
| Grouting Materials   | Page 34 |
| Questionable/Unsuitable Substrates                                       | Page 35 |
| Profiles   | Page 36 |
| Membranes and Underlayments  | Page 36 |
| • Cimentitious Backer Unit   | Page 36 |
| • Waterproof Membranes   | Page 36 |
| • Crack Isolation Membranes  | Page 36 |
| • Bonded Sound Reduction Underlayments                                   | Page 36 |
| • Flowable Hydraulic Cement Underlayment/Self-leveling Underlayment      | Page 37 |
| • Foam Core Backer Board   | Page 37 |
| • Vapor Retarder Membranes   | Page 37 |
| • Uncoupling Membranes   | Page 37 |
| • Electric Heating Membranes/Matting                                     | Page 37 |
| • Tile Testing Comparison  | Page 38 |
| Sound Control Underlayments  | Page 39 |
| • STC Ratings  | Page 39 |
| • IIC Ratings  | Page 39 |

## TABLE OF CONTENTS

|  |  |
|--|--|
| <ul style="list-style-type: none"> <li>• AllC Single Index</li> <li>• ISR Single Index</li> <li>• NISR Single Index</li> <li>• STC and IIC Ratings and Building Codes</li> <li>• Challenges</li> <li>• Concrete Slab Subfloors</li> <li>• Wood Joist Floors</li> <li>• Key Points to Remember</li> </ul> | <ul style="list-style-type: none"> <li>Page 39</li> <li>Page 39</li> <li>Page 39</li> <li>Page 39</li> <li>Page 40</li> <li>Page 40</li> <li>Page 40</li> <li>Page 40</li> </ul> |
| Testing and Standards  | Page 41  |
| <ul style="list-style-type: none"> <li>• ISO 13007 and 10545 standards</li> <li>• ASTM</li> <li>• Coefficient of Friction/Slip Resistance (COF)</li> </ul>   | <ul style="list-style-type: none"> <li>Page 41</li> <li>Page 42</li> <li>Page 44</li> </ul>  |
| Testing After Installation and Site Testing  | Page 45  |
| Life-Cycle Cost for Tile Flooring in Commercial Buildings  | Page 46  |
| 301MJ Movement Joints for Tile Installations   | Page 47  |
| 302W Tile Installed on Cement Mortar Over Masonry or Concrete Walls  | Page 50  |
| 303W Tile Installed Over Masonry Or Concrete Walls - Thin-Set Method   | Page 51  |
| 304W Tile Installed Over Gypsum Board - Thin-set Method Dry Areas Only   | Page 52  |
| 305W Tile Installed on Cementitious Backer Unit - Thin-Set Method/Walls  | Page 53  |
| 305W Tile Installed on Coated Glass Mat Backer Board   | Page 55  |
| 306W Tile Installed Over Cementitious Backer Unit on Bathtub Walls   | Page 56  |
| 306W Tile Installed on Coated Glass Mat Backer Board on Bathtub Walls  | Page 57  |
| ☀ 306W Tile Installed Over Foam Core Backer Board  | Page 58  |
| 307W Tile Installed on Cement Mortar Over Solid Backing on Interior/Exterior Walls   | Page 59  |
| 308W Tile Installed on Inter/Exterior Walls on Cement Mortar Over Wood Or Metal Studs  | Page 60  |
| 309F Tile Over Mortar Bed With Cleavage Membrane Interior Only   | Page 61  |
| 310F Tile Installed on Interior/Exterior Cement Mortar Bed on Concrete Slab  | Page 62  |
| 310F Tile Installed on Interior/Exterior Cement Mortar Bed on Concrete Slab - Chemical Resistance  | Page 63  |
| ☀ 310F Tile Installed on Interior Flowable Hydraulic Cement Underlayment/Self-Leveling Underlayment on Concrete Slab - Chemical Resistance   | Page 64  |
| ☀ 310F Tile Installed on Interior Flowable Hydraulic Cement Underlayment/Self-Leveling Underlayment on Concrete Slab - Interior Only   | Page 65  |
| 311F Tile Bonded to Concrete Slab - Thin-Set Method  | Page 66  |
| 311F Tile Bonded to Concrete Slab - Thin-Set Method - Epoxy method   | Page 67  |
| 311F Tile Bonded to Concrete Slab - Thin-Set Method - Crack concrete interior/exterior   | Page 68  |
| 311F Tile Bonded to Concrete Slab - Thin-Set Method - Uncoupling over green/young concrete   | Page 69  |
| ☀ 312F Tile Bonded to Concrete Slab - Thin-Set Method - Thin-set Method  | Page 70  |
| 313F Tile Applied Over Wood Sub-Floor in Dry Areas - Thin-set Method   | Page 71  |
| 314F Tile Over Heated Floor Systems - Mortar bed over plywood  | Page 74  |
| 314F Tile Over Heated Floor Systems - Gypsum concrete over plywood   | Page 76  |
| ☀ 314F Tile Over Heated Floor Systems - Flowable Hydraulic Cement Underlayment/Self-Leveling Underlayment Over Plywood   | Page 77  |
| 314F Tile Over Heated Floor Systems - Thin electric heating cable on plywood   | Page 78  |
| 314F Tile Over Heated Floor Systems - Thin electric heating cable with cementitious self-leveling on plywood   | Page 79  |
| 314F Tile Over Heated Floor Systems - Modular screed system over plywood   | Page 80  |
| 314F Tile Over Heated Floor Systems - Mortar bed bonded to concrete slab   | Page 81  |
| 314F Tile Over Heated Floor Systems - Thin-set on concrete slab  | Page 82  |
| 314F Tile Over Heated Floor Systems - Gypsum underlayment over concrete  | Page 83  |
| 314F Tile Over Heated Floor Systems - Modular screed system  | Page 84  |
| ☀ 314F Tile Over Heated Floor Systems - Flowable Hydraulic Cement Underlayment/Self-Leveling Underlayment Over Concrete Slab   | Page 85  |
| 315C Tile Installed on Interior/Exterior Ceilings or Soffits - Mortar bed over concrete  | Page 86  |
| 315C Tile Installed on Interior/Exterior Ceilings or Soffits - Thin-set method over cementitious backer unit   | Page 87  |
| 316B Tile Tub Over Wood Frame – Thin-set Method Over Mortar Bed  | Page 88  |
| 317SP Tile Installed Over Concrete in Swimming Pools or Tanks  | Page 89  |
| 318S Tile Installed on Interior/Exterior Stairs  | Page 91  |
| 319SR Tile on Shower Receptors - On solid backing or mortar bed over wood or metal studs   | Page 92  |
| 319SR Tile on Shower Receptors - Thin-set on backer unit/board   | Page 93  |
| 319SR/BF/C Tile on Shower Receptors - Curbless/barrier-free shower construction on recessed slab   | Page 95  |
| 319SR/BF/C Tile on Shower Receptors - Curbless/barrier-free shower construction on wood-frame  | Page 97  |
| 320R Tile Over Insulation in Refrigeration Rooms - On mortar bed   | Page 99  |
| 320R Tile Over Insulation in Refrigeration Rooms - Thin-set on cementitious backer unit  | Page 100   |
| 321SR Tile Installed in Steam Rooms - Concrete or masonry construction   | Page 101   |
| 321SR Tile Installed in Steam Rooms - Frame construction   | Page 102   |

## TABLE OF CONTENTS

|                          |   |          |
|--------------------------|---|----------|
| 322C                     | Tile Installed on Counter Tops  | Page 103 |
| 323RW                    | Tile Installed Over Existing Tile - Interior Walls Only   | Page 105 |
| 324RF                    | Tile Installed Over Existing Tile - Interior Floors Only  | Page 106 |
| ✻ 324RF                  | Tile Installed Over Existing Tile - Flowable Hydraulic Cement Underlayment / Self-Leveling Underlayment Interior Floors Only                    | Page 107 |
| 325ED                    | Exterior Decks  | Page 108 |
| 326DR                    | Drainage Systems Interior/Exterior  | Page 110 |
| 327GTF                   | Large Format (Fused) Glass Tile on Interior Floors  | Page 111 |
| 328GTW                   | Large Format (Fused) Glass Tile on Interior Walls   | Page 112 |
| 329LFT                   | Large Format Tile on Interior Floors  | Page 113 |
| 330LFT                   | Large Format Tile on Interior Walls   | Page 114 |
| 331F-SC                  | Sound Control Systems on Interior Floors - Thin-set over plywood  | Page 115 |
| 331F-SC                  | Sound Control Systems on Interior Floors - Thick system over plywood  | Page 116 |
| ✻ 331F-SC                | Sound Control Systems on Interior Floors - Flowable Hydraulic Cement Underlayment / Self-Leveling Underlayment Over Plywood                     | Page 118 |
| 331F-SC                  | Sound Control Systems on Interior Floors - Thin system on concrete with dropped ceiling   | Page 119 |
| 331F-SC                  | Sound Control Systems on Interior Floors - Thick system on concrete with dropped ceiling  | Page 120 |
| ✻ 331F-SC                | Sound Control Systems on Interior Floors - Flowable Hydraulic Cement Underlayment / Self-Leveling Underlayment on Concrete with dropped ceiling | Page 121 |
| 331F-SC                  | Sound Control Systems on Interior Floors - Thin system on concrete with no dropped ceiling  | Page 122 |
| 331F-SC                  | Sound Control Systems on Interior Floors - Thick system on concrete with no dropped ceiling   | Page 123 |
| 332F                     | Tile Bonded to Suspended Access Panel Thin-set Method   | Page 124 |
| ✻ 332F                   | Tile Bonded to Suspended Access Panel Thin-set Method - Interior dry/wet flowable hydraulic cement underlayment /self-leveling underlayment     | Page 125 |
| Tile Guide Specification |   | Page 126 |
| Glossary                 |   | Page 149 |
| Metric Conversion Guide  |   | Page 172 |

# SUSTAINABILITY

**Note:** LEED V.5 is scheduled to complete ballot and be fully available for use in 2025. Please check back on the TTMAC website <https://www.ttmac.com/en/technical/specification-addendums> for an updated summary of the key points to be aware of with the latest version of LEED V.5

Sustainability is the process of maintaining change in a balanced fashion, in which the exploitation of resources, the direction of investments, the orientation of technological development and institutional change are all in harmony and enhance both current and future potential to meet human needs and aspirations. LEED® (Leadership in Energy and Environmental Design) Green Building Rating System is the accepted standard in the US (US Green Building Council, [www.usgbc.org](http://www.usgbc.org)) and in Canada (Canada Green Building Council, [www.cagbc.org](http://www.cagbc.org)) for what constitutes a “green building”.

One of the most recognized standard is the LEED® Green Building Rating System is an assessment tool quantifying the positive contribution of different sections to the environment and well-being of the occupants. Check with Green Building Council (CaGBC or USGBC) rating system being used for the building which version is being used; such as New Construction, Schools, Core and Shell or Commercial Interiors, and what the latest version is; such as CaGBC v4, or LEED®.USGBC v4.

LEED® accreditation identifies leaders in green building design.

LEED® recognizes achievements and promotes expertise in “green” building practices through a comprehensive point-based rating system. Using the system, building owners and architects can measure their success in environmental stewardship. Achieving a LEED® certification on your project requires a clear, well defined strategy which is written up-front, checked for compliance, monitored through bid review and finally audited for success. Taking into account all areas where LEED® credits can be reached is paramount in obtaining each valuable point.

The trend in sustainability reporting is to move away from reporting recycled content and regional manufacturing to the use of product transparency information. Health Product Declarations (HPDs) and Environmental Product Declarations (EPDs) are based on a life-cycle assessment of the environmental impacts of a product or service – from the extraction and processing of raw materials, to the distribution, use and end of life of the product/service. EPDs are provided by the manufacturers to deliver this transparency information to their customers and end users.

Materials and Resources (MR) Building Product Disclosure and Optimization—Sourcing of Raw Materials. Manufacturers will provide information on Plant Location(s), based on zip (postal codes) which can be used to calculate whether or not the product and material that is extracted, manufactured, and purchased is within 100 miles (160 kilometers) of the project. Percentages of raw materials by product category can be shared as part of the transparency process by the manufacturer. This category aims to minimize the embodied energy and other impacts associated with the extraction, processing, transportation, maintenance and disposal of building materials by adopting a harmonized life-cycle approach.

Recycled Content is expressed in Percentage of Recycled Content and the source (Pre-Consumer or Post-Consumer) is provided by the manufacturer.

MR Credit Building Product Disclosure and Optimization— Environmental Product Declarations:

Option 1 of MR credit BPDO – Material Ingredients relates to transparency, with the incentive for project teams to gather information about building materials and identify specific ingredients of a given product. It requires selection of products for which manufacturers disclose a product’s chemical inventory to at least 0.1% or (1,000 ppm). That is to say 99.9% of a product’s ingredients must be disclosed.

The USGBC’s LEED v4 BD+C Reference Guide Addenda tables in April 2016 and April 2017 expanded the list of acceptable programs to include Declare, ANSI/BIFMA e3 Furniture Sustainability Standard, Cradle to Cradle Material Health Certificate, Product Lens Certification and Facts - NSF/ANSI 336, in addition to Manufacturer Inventory, Health Product Declaration (HPD), and Cradle to Cradle. Note that Material Safety Data Sheets (MSDS) are only required to report ingredients to 1% (10,000 ppm), so unless the MSDS specifically states materials have been disclosed to 1,000 ppm, it is not compliant documentation. For a complete list of acceptable programs refer to the Credit Library.

For assistance identifying compliant documentation consult this website for guidance on HPDs and this summary of Declare labels.

Option 2, Material Ingredient Optimization, relates to reducing impact on health and the environment, with the incentive for project teams to go a step further and make choices about less harmful products. It requires selection of products which comply with either GreenScreen v1.2 Benchmark, REACH Optimization or Cradle to Cradle. Note that manufacturers must disclose a product’s chemical inventory to at least 0.01% (100 ppm), as 100 ppm is a more granular level of detail than 1,000 ppm.

VOC Content of a product is confirmed (or not) to conform to the South Coast Air Quality Management District (SCAQMD) Rule #1168 for Ceramic Glass, Porcelain, & Stone Tile Adhesive and the content in g/L is stated.

VOC Emission of a product, when tested should be certified by CRI (Carpet & Rug Institute) Green Label Plus to conform to the California Department of Health; Section 01350 requirements. CRI Green Label Plus # GLP01646. CRI Website at [www.carpet-rug.org](http://www.carpet-rug.org) can be consulted for additional information.

Additional Product Transparency such as Manufacturer Inventory (MI), Health Product Declaration (HPD), Cradle to Cradle (C2C), Living Building Challenge (LBC) 'red list free'. When considering LEED V4, manufacturer should publicly disclose an ingredients list within this product on the Safety Data Sheet (SDS) as required by laws and regulations. The portion of the ingredients that are not required to be disclosed on the SDS are considered to be confidential business information. These ingredients are screened per the most current LBC 'red list' (v3.1) ILFI website: <https://living-future.org/declare/declare-about/red-list/> and are found to not contain any intentionally added 'red list' chemicals.

Moving forward manufacturers will be providing a "PRODUCT REPORT" which generally will include the following\*:

PERFORMANCE TRANSPARENCY (which is typically the product datasheet)

REGULATORY TRANSPARENCY (in essence, this is the SDS - Safety Data Sheet)

SUSTAINABILITY PRODUCT REPORT (A sustainability report in its most basic form is a report about an organization's environmental and social performance)

ENVIRONMENTAL TRANSPARENCY (is the EPD (Environmental Product Declaration); is a standardized way of providing data about the environmental impacts of a product through the product life cycle)

VOC TRANSPARENCY (generally a certificate issued by a 3rd party)

CHEMICAL TRANSPARENCY (generally a certificate issued by a 3rd party listing the MI (Material Ingredients)).

\*It should be noted that reporting is voluntary.

## NOTES FOR THE PROFESSIONAL

### Surface Preparation:

- All supporting surfaces should be structurally sound, solid, stable, flat, plumb and true with a maximum permissible variation of 6 mm in 3000 mm from the required plane. Surfaces should be clean and free of dust, oil, grease, paint, tar, wax, curing agent, primer, sealer, form release agent and any deleterious substance or conditions that may prevent, reduce or affect adhesion or performance. Concrete must be cured for a minimum of 28 days (preferably 90 days or longer to minimize the effect of shrinkage) and should have a steel trowel and fine broom finish for thin-set applications and should be screed finished for mortar bed applications. If a cleavage membrane is being used, concrete should be steel trowel finished; if a cleavage membrane is to be applied over a rough surface, a 6 mm sand-bed must be applied under the cleavage membrane.
- Variances in substrate not to exceed 6 mm in 3000 mm for mortar bed or thin-set applications.
- When specifying any tile or stone with at least one edge greater than 380 mm, more stringent tolerances of the substrate are required and must include a specific and separate requirement to bring the standard supporting surface maximum permissible variation [e.g. 6 mm in 3000 mm and 3 mm in 600 mm] tolerances into compliance to 3 mm in 3000 mm and 1.5 mm in 600 mm tolerances.
- Substrate repair variations of 5 mm or less can be levelled with a latex Portland cement mortar or an epoxy mortar levelling and allowed to set before application of other materials. A levelling coat in excess of 5 mm should be installed with a Large and Heavy Tile mortar or a mortar bed. If required, the method must be specified by the consultant.
- For rectified tiles and/ or grout joints of 5 mm or less, a more stringent tolerance of 3 mm in 3000 is required.
- Refer to specification section.

### Environmental Conditions:

- Tile should not be installed at temperatures below 12°C when using Portland cement mortars, dry-set mortars, latex-Portland cement mortars or bond coat and temperature should be maintained at a minimum of 12°C or a maximum of 38°C until cured. Follow manufacturers recommendations.
- Certain rapid-set, dry-set or latex mortars may be suitable for use at temperatures as low as 5°C. Manufacturer's recommendations must be followed.
- Epoxy mortars and grouts should not be applied at temperatures below 16°C or above 32°C or follow manufacturer's recommendations.

### Site Conditions:

Protecting new tile work – General contractor to provide appropriate protection to completed tile work. Protect work of other trades. Prohibit traffic during installation and for 48 hours after completion or longer if required by tile contractor for unique installation requirements. Protect floor from impact and vibration for a minimum of 48 hours after installation. On completion of tile floor it is the responsibility of the owner/agent or general contractor to protect the floor from damage.

### Materials:

- Materials used, must, at a minimum, meet the requirements of relevant standards listed under “References”.
- Metal lath – refer to Detail 307W-2019-2021. Attachment of metal lath should be with fasteners on maximum 600 mm o.c. having a pull out resistance of minimum of 400 N. Use galvanized or stainless steel lath in wet areas and exterior applications.
- Do not use paper-back, mesh-back or dot mounted tile for exterior use or in locations of extreme moisture unless the manufacturer guarantees in writing that the material is suitable for this type of installation.
- For colour and size consistency, tile should be from the same production run, dye lot, calibre and batch number. If shading variation is evident, the consultant, owner, designer and architect must be notified prior to installation. Slight shading variations in the manufacturing of the tile may occur even with the highest modern technologies. On large quantity projects, it may not be possible to obtain all tile from the same production run, dye lot, calibre or batch number, therefore, consult with the supplier or manufacturer to ensure tile consistency.
- Natural stone is a product of nature and is not subject to the rules of consistency that apply to manufactured materials. The selection of natural stone tile (marble, granite, limestone and slate) should never be made on the basis of viewing one single sample, as these products are subject to variation in their tonal qualities, veining and shading variations. However, the aforementioned characteristics make these products highly desirable and therefore selection should always be made by viewing sufficient material in order to observe an adequate range of the material's characteristics prior to installation.
- Material must be inspected prior to installation.
- Use or installation constitutes acceptance of materials.
- Installer to work from multiple boxes or multiple pallets to ensure even shading distribution.

### Mock-ups:

Mock-ups should be installed as per the specification when being used to evaluate the entire assembly. Specify whether the mock-up will form an integral part of the installation. Material mock-ups are intended to show the range and appearance of the tile, and the standard of the installation workmanship. Mock-ups may be specified to pre-determine and/or negotiate the range of a stone. Mock-ups should be used for approval by all parties.

### Execution:

- Movement Joints are mandatory – see Detail 301MJ-2025.
- Grout joint width for floors and walls are normally 2 mm to 6 mm depending on the type of material. Required grout joint width (joint width is the space between vertical edges of tile) should be specified for both the minimum and maximum width of joint. (butt joints are not acceptable). Tile with bevelled or cushioned edges will appear to have wider grout joints than specified. For ease of maintenance, grout joints should be installed flush to tile face. Grout depth maximum tolerance must not exceed the depth of the bevelled or cushion edge of the tile. For rectified tile, grout must be close to flush with the surface of the tile for joint widths up to 6 mm; maximum allowable grout concave depression not to exceed 1 mm for joints in excess of 6 mm up to 10 mm. Concave depression in the middle of the joints in excess of 10 mm width not to exceed 2 mm. For epoxy grouts, joints must be filled close to flush with tile edges to a maximum concave depression in the middle of the joint not exceeding 1 mm for joints up to 6 mm and 2 mm for wider joints up to 10 mm. Manufacturer's recommendations must be followed. A minimum of 2/3 of joint depth should be kept open for grouting and grout must penetrate the joint to the bond coat.
- Latex-Portland cement mortar will improve adhesion of porcelain tile and Flat back and notched back trowelling will assist in achieving higher bond strengths.
- When tiles are set by the thin-set method on exterior surfaces, in areas subject to heavy loads, in wet areas or for tile with any edge longer than 380 mm that are going to be subjected to heavy load impact, a minimum of 95% coverage must be achieved. The bonding material must be notched in horizontal straight lines. Set tile on the freshly notched thin-set mortar, slide tile back and forth at 90° to the notches. This method can produce maximum coverage, with the corners and edges fully supported.
- Flat back and notched back trowelling may be necessary to achieve a minimum of 95% coverage when installing tile with any edge larger than 300 mm. Flat back and notched back trowelling also improves adhesion to tiles with bond breakers such as dust, kiln release agents and dirt, as well as tile with a raised or textured back. Flat back and notched back trowelling involves application of a thin trowelled coat to the back side of the tile using the flat side of the trowel immediately before setting the tile.
- Notch back trowelling involves additional modified/ non-modified dry-set mortar (thin-set mortar) applied to the back- side of ceramic, porcelain, glass and stone tile and uniformly combed in one direction with an appropriate notched trowel just before the tile is embedded into the setting mortar
- Wipe the backs of all tiles with a damp cloth to remove the dusty film that can prevent the adhesive from bonding to the tile.
- Immediately prior to setting ungauged slate, marble, stone or large sized ceramic, tile must be flat and notch back trowelled through a push box or box screed to achieve a uniform thickness of tile and mortar combined.
- Tile must always be set while bond coat is wet and tacky and has not skinned over.
- For rough textured or irregular surface tile it is advisable to pre-seal or pre-wax tile prior to grouting.
- For broken –joint pattern with a tile that is rectangular, the off-set should not be more than 33%.
- The waterproofing membrane should be installed at least to the shower-head or preferably to the ceiling.
- Plywood even if exterior grade is not recommended as a substrate on walls due to potential warpage from humidity and seasonal changes.

Guidelines cannot address every installation. The type and size of tile, use or service requirements, environmental conditions, tile spacing and individual manufacturer's recommendations are all factors that should be considered and specified.



The TTMAC Specifications and Technical Research Committee has decided to identify those installation methods in the following pages that require unique installation knowledge and experience. The tile contractor selected for these installations should be a member in good standing with the TTMAC and must have a minimum of 5 years experience and references for the installation method specified.

### Recycling & Environmental Responsibilities

Many manufacturers are moving towards environmentally friendly production. For many years there have been tiles made from recycled glass. The movement from tunnel (slow fire) kilns to fast fire (porcelain) kilns has helped reduce energy consumption. In 1992 the European Community developed a product certification policy called Eco-Label. Under the HFC (Hard Floor Coverings) category, manufacturers must meet strict criteria to ensure that their products have a reduced impact on the environment. The Eco-Label criteria examines the entire process from raw materials, through production, distribution (including packaging) and finally to disposal of the product to determine its impact on the environment. Factories are inspected for water recycling, pollution emissions, use of hazardous substances (including lead and cadmium) and waste management. Only 30% of the tile currently on the market has achieved the Eco-Label status.

Ask manufacturers for a copy of the label or look for it on their product brochures. More information can be found at [Europa.eu.int/ecolabel.it](http://Europa.eu.int/ecolabel.it). Specifying products from factories that have achieved Eco-Label status is a powerful way to encourage ecological manufacturing.

### Cleaning

The more slip resistance a tile has, the more difficult it is to keep clean. Textured tiles grab the bottom of shoes and therefore the floor will get dirtier, faster. Textured surfaces do not release dirt as easily as smooth tiles and may require more maintenance to be kept clean.

## SUCCESSFUL TILE AND STONE PROJECTS ROLES AND RESPONSIBILITIES

Two of the most important aesthetic components of construction are floor and wall finishes. We often don't realize the extent of collaboration required between the design team, (architects, engineers, interior designers), general contractors, tile or stone installation firms, tile or stone suppliers and floor preparation/installation product manufacturers, to achieve a successful long term use of the completed installation.

It is helpful to understand the responsibilities and limitations of each member of the team in order to provide the necessary structural and installation qualifications required for success. Each component of construction is regulated by codes from municipalities, provinces, countries and by factors within their own industries. Recommendations for tile and stone installations, for example, are supported by the Terrazzo, Tile and Marble Association of Canada with the Specification Guide 09 30 00 Tile installation Manual (Current edition), updated regularly to reflect changes to the construction industry.

Exact and precise communication and a full understanding of individual responsibilities between all parties involved in the project is a crucial component for success. What are the specific responsibilities? A pre-installation site meeting, involving all members of the team significantly reduces surprise situations on site and insures all criteria are met. Attached are some basic guidelines to consider when detailing roles and responsibilities of the project team.

### Design Team (Architects, Engineers, Interior Designers, Project Managers)

As it is a team effort to fulfill the project needs, the design team is the team leader. The design team usually has the final responsibility in determining the material performance requirements and appearance for all products listed for inclusion on the project. Using consultation from the installer and tile or stone supplier team members, they incorporate their choice of materials and methods to ensure they achieve the project goals. Prior to preparing the specification, they can alleviate site issues by confirming compatibility between the various products of the tile or stone by consulting manufacturers' technical representatives and incorporating appropriate decisions into the written documents. The design team is responsible to ensure that the support surfaces have been built to the requirements of the finish product supplier, and if not, to specify the requirements for levelling and straightening to bring the support surface within tolerance required by the finish product.

### Tile or Stone Supplier

Tile and stone suppliers are responsible to ensure their product will meet the aesthetic, warranty and functional needs of the owner/design team. They must also provide precise industry and building code standard identification of which installation materials and methods will achieve the performance requirements of the project.

NOTE: The tile or stone supplier should build trust and maintain integrity in their recommendations to the owner/design team, keeping in mind that a failure to meet the performance requirements of the project because of too much emphasis on a product's appearance will damage the supplier's reputation and potentially burden the owner/design team with repair and replacement costs.

### Preparation and Installation Product Manufacturer

Product manufacturers are responsible to ensure their product will meet the warranty and functional needs of the owner/design team. Simply put, manufacturers provide products designed to meet the performance requirements of the complete assembly. They will provide product qualifications to meet the performance requirements outlined by the design team and as stipulated by industry standards. Manufacturers provide, through documentation, the performance values of their products as well as the site conditions required to meet these declared values. Manufacturers are not responsible for the methodology chosen to achieve code, preparation, or structural requirements or other duties that are the contractual obligation of others for a given project. These fall under the responsibility of the general contractor and the finish installer.

NOTE: A distributor is not the technical representative for the manufacturer and as such, it is important the design team verifies that the actual manufacturer supports any information provided by the distributor.

### Tile or Stone Installation Firm

The installation firm is responsible to verify and prepare the substrate so that they can properly install the tile or stone according to industry standards and the instructions provided by the material manufacturer. They must confirm that the chosen installation system meets the requirements stipulated by the tile or stone supplier. They must also obtain assurances from the general contractor that other structural, substrate, or any other conditions (such as cure times, moisture/vapour transmission, temperature, post installation protection etc.) concerning the chosen application can be met. The installation firm must also execute any other requirement set forth in their particular section of the project specification or identify to the design team where conflicts or disconnects occur so that an appropriate solution can be agreed upon.

### Constructor (General contractor, Construction Manager and/or Design Builder)

The constructor is responsible to ensure that the structural and installation criteria as provided by the tile or stone installer can be respected. This includes allocation and provision of proper installation and protection environments needed prior to, during, and after the installation, as well as respecting cure times before exposing the installation to work from other trades. The constructor must execute and coordinate all the requirements set forth in the project specifications.

NOTE: Industry standards and recommendations are developed by testing and historical monitoring over many years. They are based on minimal requirements and conditions. Project success is based on the conditions stipulated in these recommendations. Whenever recommendations are presented contradicting or creating a non-conforming application to these recommendations, they should be supported with warranty, matching or better than the warranties provided by the suppliers of the industry standard method.

**This section is intended for use as a general guideline only and is not a legal or binding document.**



### Why CCTI?

The Terrazzo Tile and Marble Association of Canada is the governing body in the country for tile installation. We are the body who writes the 093000 Tile Installation Manual, the technical book, which is followed by all in the industry, it is quoted by specifiers in their new projects and well known by architects, designers and everyone else involved in the hardsurface industry.

TTMAC discussed with all its members the need to have tile setters certified, to differentiate between someone who knows how to install tile according to specifications and someone who learns how to install tiles on youtube. This certification course is very comprehensive and very well set. The curriculum was written based on the specification manual and has been scrutinized by many. After taking the online course as well as the hands-on test, all installers who pass the test, will be listed on our website, the 09 30 00 Manual and will all be promoted to the industry as certified tile installers.

### LIST OF THE GRADUATES

| Installers Name       | Employer                 | Certification | City            | Prov |
|-----------------------|--------------------------|---------------|-----------------|------|
| Max Poulin            | Mountain Top Surfaces    | 2022-001      | Calgary         | AB   |
| Jamie Scobie          | Island Floors            | 2022-002      | Victoria        | BC   |
| Patrick Keith Fogarty | True Line Flooring       | 2022-003      | Pender Island   | BC   |
| Kevin Enstedt         | Huard-Duncan Group       | 2022-004      | New West        | BC   |
| Brad Smith            | City of Vancouver        | 2022-005      | Vancouver       | BC   |
| Mike Bevacqua         | Apex Granite             | 2022-006      | Burnaby         | BC   |
| Trevor Anderson       | WNA Tile                 | 2022-007      | St. Albert      | SK   |
| Scott McGillivray     | Nu-Way Floors            | 2022-008      | Calgary         | AB   |
| Roman Tataru          | Self Employed            | 2022-009      | Calgary         | AB   |
| Byoungwoo Yoo         | Antex Western            | 2022-010      | Winnipeg        | MB   |
| Tyler Bergen          | Surface Studio           | 2022-011      | Winnipeg        | MB   |
| Bosung Kwon           | Antex Western            | 2022-012      | Winnipeg        | MB   |
| Donghun Lee           | Antex Western            | 2022-013      | Winnipeg        | MB   |
| Jungmin Shin          | Antex Western            | 2022-014      | Winnipeg        | MB   |
| Dan Wall              | Covenant Construction    | 2022-015      | Toronto         | ON   |
| Spencer Judd          | Tile with Style BC       | 2022-016      | Kamloops        | BC   |
| Nolan Wilson          | Island Floors            | 2022-017      | Victoria        | BC   |
| Alin Alexoaie         | Titan Edge               | 2022-018      | Burnaby         | BC   |
| Sebastian Plank       | Schluter Systems         | 2022-019      | Toronto         | ON   |
| Tony Natalie          | Page Flooring            | 2022-020      | Pickering       | ON   |
| Carlos Sousa          | York Marble              | 2022-021      | Toronto         | ON   |
| Eric Breuker          | York Marble              | 2022-022      | Toronto         | ON   |
| Bledar Lulej          | Sander Tile Construction | 2022-023      | Ottawa          | ON   |
| Dave Wilson           | Cut Above Reno           | 2023-024      | Burnaby         | BC   |
| Kevin Stahl           | Alfredo Marble & Tile    | 2023-025      | Calgary         | AB   |
| Brad Alexander        | Decor Tile Company       | 2023-026      | Sturgeon County | AB   |
| Vernon Nyagura        | Filip Tile and Stone     | 2023-027      | Delta           | BC   |
| Filip Credu           | Filip Tile and Stone     | 2023-028      | Delta           | BC   |
| Henry Nartey          | Filip Tile and Stone     | 2023-029      | Delta           | BC   |
| Colin Rymak           | Rymak Construction       | 2023-030      | Calgary         | AB   |
| James Deegan          | James Deegan             | 2024-031      | Toronto         | ON   |
| Anthony Hudyman       | Humblewood Homes         | 2024-032      | Toronto         | ON   |

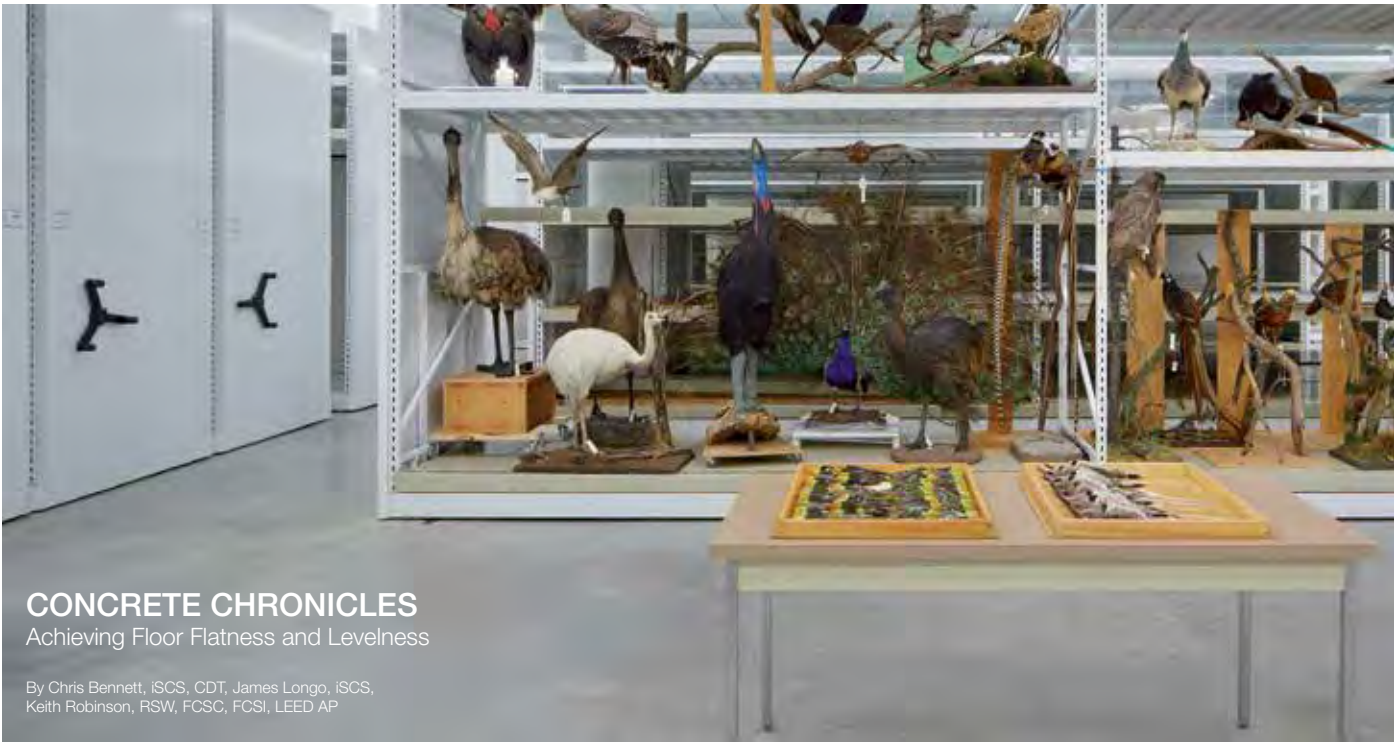

# CONCRETE CHRONICLES

## Achieving Floor Flatness and Levelness

By Chris Bennett, ISCS, CDT, James Longo, ISCS, Keith Robinson, RSW, FCSC, FCSI, LEED AP

Photo courtesy of Dialog

Concrete floors are used in wide-ranging facilities, such as industrial data centres, commercial high-rise buildings, and residential homes. Concrete floor quality depends on several factors, including the concrete mix design, the curing process, including consolidation and finishing. However, one of the seemingly simple, but often complex aspects of concrete floors, impacting performance and functionality, are floor flatness (FF) and floor levelness (FL).

In a world where project manuals require competing benchmarks for concrete and flooring, as well as vagueness on responsibility within the flatwork and flooring trades for ultimate responsibility for FF/FL, it is important to understand these two factors and how they affect not only the overall quality of concrete floors (and other floor finishes), but what is the best way to go about designing and specifying for the best outcome possible.

### Floor flatness and floor levelness

Floor flatness refers to the smoothness and uniformity of the concrete surface. It is measured by calculating the height difference, between the highest and lowest points on the surface over a specified distance. The flatness of a concrete floor is critical in many applications, especially in commercial and industrial settings where heavy machinery and equipment are used. A flat floor ensures the equipment operates smoothly and efficiently, reduces the risk of damage to the machinery, and improves safety for workers. A non-flat floor can also cause problems with the installation of flooring materials, such as tiles or carpeting, which require a level surface (see Figure 1).

Floor levelness refers to the evenness of the concrete floor in terms of its slope and elevation. It is measured by calculating the difference in height between the floor surface and a designated reference point, such as a horizontal plane. Floor levelness is essential for various applications, such as building foundations, where a level floor ensures the load is evenly distributed and the structure remains stable. It is also critical in commercial and industrial settings where liquids are stored or transported, such as food processing plants, where a level floor ensures the liquids flow uniformly and do not accumulate in certain areas.

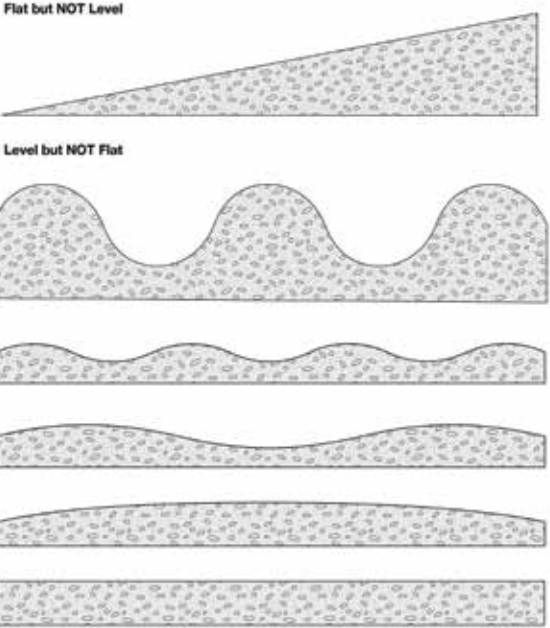

Illustration courtesy Bennett Build

Floor flatness is measured by calculating the height difference, between the highest and lowest points over a specified distance. Floor levelness is measured by calculating the height difference between the surface and designated reference point.

### Levelness and flatness

To achieve the desired level of flatness and levelness in concrete floors, various techniques and tools are used. Getting consistent FF and FL on concrete slabs requires careful planning, execution, and quality control (QC) throughout the construction process. (See Figure 2 for an example of an outline spec.) Here are some general steps that can help to achieve consistent FF and FL:

| Related Sections: |  |
|-------------------|--|
| 1.                | Division 3 Section "Architectural Concrete" for general building applications of specially finished formed concrete. |
| 2.                | Division 3 Section "Concrete Topping" for emery- and iron-aggregate concrete floor toppings.                         |
| 3.                | Division 3 Section "Polished Concrete Finishing" for polishing slabs and finishing benchmarks.                       |
| 4.                | Division 31 Section "Earth Moving" for drainage fill under slabs-on-grade.   |
| 5.                | Division 32 Section "Concrete Paving" for concrete pavement and walks.   |

| REFERENCED STANDARDS   |   |
|--|---|
| ASME B46.1-2019,   | Surface Texture (Surface Roughness, Waviness, and Lay)  |
| ASTM C1895-20  | Standard Test Method for Determination of Mohs Scratch Hardness Tests                                     |
| ASTM E1155-20  | Standard Test Method for Determining FF Floor Flatness and FL Floor Levelness Numbers                     |
| A21 – Best Practices for Measuring Substrate Flatness for Floor Covering Installations |   |
| ASTM D5767-18  | Standard Test Method for Instrumental Measurement of Distinctness of Image (DOI) Gloss of Coated Surfaces |

An example of required reference standards for various slab aspects, including FF/FL, from a 03 30 00 CIP specification to receive a polished concrete finish.

#### Start with a flat, compacted, and level base

Before pouring the concrete, ensure the base on which the slab will be constructed is level and flat. This can be achieved by properly grading and compacting the soil, and using a laser level or other equipment to ensure the base is within the required tolerances.

#### Use the right mix design and curing techniques

The mix design of the concrete, including the type and amount of cement, aggregate, and water, can affect the flatness and levelness of the finished slab. Moreover, proper curing techniques can help to prevent cracking and warping of the concrete, which can affect its flatness and levelness. The latter is especially true with newer low-carbon mix designs where older methods of curing (i.e. topical spray applications, membranes, etc.) may not cure sufficiently to reduce undulation, curling, and other manifestations of reduced FF and FL. Internally cured concrete (ICC) approaches can dramatically reduce volume change through better curing. Consult with a concrete expert to determine the appropriate mix design and curing methods for a specific project.

#### Control the placement and finishing process

During the concrete placement and finishing process, it is important to control the rate of placement, use the appropriate tools, and properly consolidate and level the concrete to prevent the formation of air pockets or voids.

The use of a power trowel, laser screed, or other finishing equipment should be carefully controlled to prevent trowel marks or other irregularities that can affect FF and FL. Trowel harmonics, vibrations, and resonances that occur when a power trowel is used to finish new concrete, can play an important part in missing or achieving your benchmarks. Different blades as well as the speed and angle of trowelling will affect the plastic concrete differently. Perform QC testing

Throughout the construction process, it is important to perform regular QC testing, such as using a laser screed or other equipment to measure FF and FL. This can help to identify and correct any issues that may arise during the construction process, and ensure the finished slab meets the required standards.

By following these steps and working with experienced concrete professionals, it is possible to achieve consistent FF and FL on concrete slabs.

## Measuring FF and FL of concrete

FF and FL are measured in accordance with ASTM E1155 for slabs on grade. For elevated slabs, FL is only valid at placement and before shoring is pulled, but the FF factor will remain important. Standardized measurements are employed at regular intervals, uniformly distributed across the test section, properly distanced from slab boundaries, construction joints, and other breaks in plane (e.g. block-outs or penetrations). Testing must be conducted within 72 hours of concrete placement and prior to removal of any shoring to comply with the test standard.

The adoption of the standardization of FF/FL testing in Division 03 allows for uniform testing of concrete slabs during the threshold inspection, delivering results to the architecture and engineering team, showing compliance to or failure in meeting design specification requirements.

The ASTM E1155 measurement standard was developed for use with concrete finishing and confirming structural tolerances at the fixed point in time described above. Although referenced for use by other trades affected by FF/FL, its use is limited because data are made along defined lines of measurement and do not provide an overall evaluation of smoothness and evenness, which is better evaluated using straight edge measurements as described below.



How a floor covering installer verifies flatness of a substrate provided by the Constructor (GC) using a 3-m (10-ft) straightedge has always been a contentious issue. The A21–Best Practices for Measuring Substrate Flatness for Floor Covering Installations document includes scope of the best practice, definitions, straightedge testing guidance, and alternative measurement technologies.

Photos courtesy National Floor Covering Association of Canada (NFCA)

## Measuring flatness for flooring

In contrast to FF/FL testing for the concrete, the flooring industry employs the straight edge method for floor flatness. Straight edge measurements are indicated in the allowable deviation in plane over a specific distance, such as 6 mm (0.2 in.) deviation in 3 m (10 ft) span represented as 6 mm in 3 m (0.2 in. in 10 ft).

There are three primary challenges that result from the “inches and feet” straight edge method and the FF/FL method:

1. This is no correlation between the FF/FL values and the inches in feet values.
2. The straight edge method does not require specific placement techniques for evaluation, leaving an unlimited amount of variability dictated solely by the tester.
3. The time between Division 03 FF/FL testing and floor flatness straight edge testing are typically several months, up to a year apart.

- a. This means natural variations in flatness and levelness that occur as concrete cures and desiccates, decreases the initial values obtained within 72 hours obsolete.
- b. The initial values can change between 20 to 40 % as a minimum expectation or as much as 50 to 70 %, depending on how the concrete was cured, the FF/FL value specified, the weather conditions concrete experienced during construction, the type of concrete mix used, or the early application of loads on the finished concrete surfaces.
- c. An initial value of FF25/FL20 may decrease to FF15/FL17 in a worst-case scenario, making the concrete substrate unacceptable for most floor covering manufacturer's straight edge measurement requirements.

- "Fault" is the word commonly used during construction when there is a perceived defect in the work, as stated above, the progress of change to the FF/FL is a natural process that needs to be accounted for within the project documents.
- As indicated above, deviation from the measured tolerance on day three until the floor covering is installed eight, nine, or 12 or months later is a natural part of aging concrete, meaning that pointing to an at "fault" trade is inappropriate and unjustifiable unless there were specific defects identified during the ASTM E 1155 measurements.
- "Correction" is a better word and can be used to describe the grinding and filling operations typically required to address requirements for straight edge tolerances required by floor covering manufacturers in the form of a cash allowance as recommended by the American Concrete Institute (ACI) and American Society of Concrete Contractors (ASCC) for more than 20 years.
- Correction of concrete services form a part of Division 03 scope of deliverables and are described by most concrete finishing training and apprenticeship programs, and do not form a part of the traditional deliverables forming Division 09.
- Division 09 is only responsible for minimal skim coating, average roughness (Ra), or concrete surface profile (CSP) range, and light abrasion to create a surface that will be compatible with floor covering adhesives and to minimize telegraphing of surface irregularities through resilient materials that will show on the final surface finish.
- Most corrections typically require minimal correction, usually in the range of a few millimetres or 1.5 mm (0.0625 in.), which can be achieved by bump grinding or planning, and minimal filling. Finishing aids incorporating colloidal silica or nano modified cements (NMC) can help fill voids and surface imperfections during the refinishing process without the potential for bond inhibiting side effects often from silicate or membrane forming curing compounds or surface treatments.
- Floors at the higher range of deviation may require installation of self-levelling underlayments or other topping materials.



*Before pouring the concrete, ensure the base on which the slab will be constructed is level and flat. This can be achieved by properly grading and compacting the soil to help ensure the base is within the required tolerances.*



*Floor profiler and joint deflection meters measure floor profiles (FF/FL) and joint stability in accordance with performance specifications and standards.*

Photo courtesy Somero Matsson Group

Photo courtesy Husqvarna Construction Products

When floors are measured for flatness, concrete has substantially cured. That curing alters the flatness profile of the concrete. While there is too much variability to define specific or typical values in flatness change over time, it is not uncommon for concrete to undergo these changes over a period of six to 12 months after placement. When the floor covering installer contractor initiates straight edge testing, the concrete flatness may not be indicative of the slab delivered by the concrete contractor within 72 hours after placement and will likely require some degree of wet or dry mechanical grinding to correct the natural decrease in floor flatness and levelness tolerances before they are called to site.

### Uncommon ground

The use of two separate and incongruent measurement protocols in Division 03 and Division 09 often necessitates additional work to bridge the gap between them. This work generally results in change orders to grind or fill (lower and raise) elevations to an acceptable and uniform plane that meets the flooring specification requirements. Assigning the "fault" is difficult and unforeseen costs and scope durations escalate as a result.



Photo courtesy Dialog

In the back-of-house areas of the Royal Alberta Museum, a low-maintenance finish resistant to dusting was achieved by employing polished concrete.

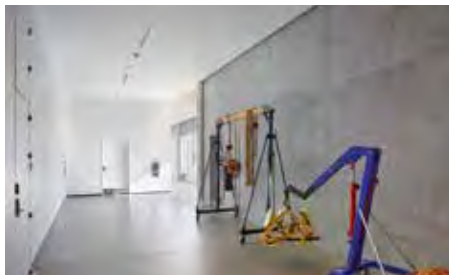

The National Floor Covering Association of Canada (NFCAC) developed a best practice for making straight edge measurements.<sup>1</sup> NFCAC is presenting their approach to the industry in hopes that a uniform approach to making measurements that respect the differences between concrete and floor covering trades will be adopted as standard practice in the coming months.

The current method used by architects, engineers, and specifiers for specifying concrete placement to higher FF/FL values to account for natural changes to smoothness and evenness is misguided, since the statistical nature of the ASTM E1155 measurement procedure results in greater deviation when higher values are specified. A concrete surface specified to FF50/FL35 will decrease in uniformity to a greater per cent difference than a floor specified to FF25/FL20, which is considered as standard achievable concrete finishing without using special installation techniques.

While it is possible to improve concrete FF stability through design, curing improvement, and laser screeding, secondary FF testing timing would be required closer to the time of floor placement to assess deviation over time. The measurement at threshold (within

72 hours of concrete placement) and again via local FF testing (within seven to 14 days of flooring installation) would identify variability over time and allow for future design alterations based on stability performance. However, as long as the FF is measured in Division 03 at the time of placement and the straight edge method is employed at the time of floor covering installation, the industry will continue to search in the dark for solutions. Decades have proven that it is difficult to solve for X when speaking in two incompatible languages. The NFCAC “Best Practice for Measuring Substrate Flatness for Flooring Installation” is the first concerted attempt to bring light to this issue.

**Conclusion**

Concrete floors, found in a myriad of structures with varying performance requirements, epitomize a realm where meticulous design and craftsmanship intersect. Conducting this symphony of elements, the concrete mix, the often-overlooked curing process, and the precision of finishing orchestrate the creation of not just floors, but functional canvases. Yet, in this complex dance, floor flatness (FF) and floor levelness (FL), harmonizing performance and esthetics provide something to hold on to. In a world laden with benchmarks and blurred responsibilities, these factors become the silent architects of quality and contingency protections. FF, ensuring the smooth operation of machinery, and FL, dictating stability and fluidity, demand a choreography of planning and execution. Picture a canvas: the base is level, the mix design a carefully chosen palette, and the curing process an artful stroke. This, coupled with meticulous control in placement and finishing, forms the symphony. However, the challenge lies in the discord between measurement methods, a dissonance the NFCAC’s best practice aims to harmonize. Until a unified language emerges, the pursuit of overcoming these challenges continues—a quest for simplicity in the intricate work of concrete construction.

*Chris Bennett, iSCS, CDT, is the founder of Bennett Build, an industry-recognized leader in concrete consulting and owner representation. His portfolio includes the longest history of helping project teams in commercial internal curing in North America. Bennett has also helped improve continuing education in concrete by facilitating such programs as The National Concrete and Corrosion Symposium (NCCS), Concrete North, and various hands-on reality labs with institutions such as University of Alberta, the University of Akron NCERCAMP, the Construction Specifications Institute (CSI), and the International Society for Construction Sciences. His work has been featured at Dreamforce, Construct, Praxis!, World of Concrete, and more. He can be reached at [chris@bennettbuild.us](mailto:chris@bennettbuild.us).*

*James Longo, iSCS, is the principle of Specified Surfaces, a U.S. based specialty distributor in the flooring and concrete industry. With more than 30 years industry experience spanning installation, manufacturing, consulting, distribution and sales, Longo brings a 360-degree view of the challenges and solutions to delivering consistent, warranted flooring installation systems. Specified Surfaces works directly with professional flooring contractors, owners, A/D teams, and general contractors in the U.S. and Canada. He can be reached at [jlongo@specifiedsurfaces.com](mailto:jlongo@specifiedsurfaces.com).*

*Keith Robinson, RSW, FCSC, FCSI, is a retired architectural technologist and specifier based in Edmonton, Alta. Robinson also instructs courses for the University of Alberta, acts as an advisor to several construction groups, and sits on many standards review committees for ASTM and the National Fire Protection Association (NFPA), and the A21–Best Practices for Measuring Substrate Flatness for Floor Covering Installations. He can be reached at [krobinson@dialogdesign.ca](mailto:krobinson@dialogdesign.ca).*

**Note to Specifier:**

According to the above technical article reprinted under permission of Construction Canada Magazine: " Applied finish manufacturers often employ straightedge tolerances which have proven not to be practical for concrete floor construction" AND "Tile contractors who wish to obtain surface tolerances in excess of Class B (FF25-35) will need to include allowances to level the floor with a mortar bed or self-leveling screed to suit their needs".

This essentially indicates that floor flatness requirements for most floor finishes cannot be achieved with conventional concrete floor finishing methods. Your specification should include the following requirement: *As the level of work and material required to meet the flatness and straightedge requirements cannot be predetermined, it is essential the specification provide an allowance, permitting the Tile contractor (Division 9) to provide pricing for such preparative work after inspection of the cured concrete.*

**TABLE 1**

Grout Joint Size Relative to Subfloor Flatness Minimum Requirements  
Minimum Subfloor Flatness using ASTM E1155-06 FF (SOFF) or a 3000mm (10') Straightedge

| Tile Size* |         | Grout Joint Size   |                 | Grout Joint Size   |                 | Grout Joint Size  |                 |
|------------|---------|--------------------|-----------------|--------------------|-----------------|-------------------|-----------------|
| Inch       | mm      | Inch               | mm              | Inch               | mm              | Inch              | mm              |
| +/- 1/2"   | +/- 13  | 1/4" or larger     | 7 or larger     | 3/16"              | 5               | 1/8"              | 3               |
| 8" x 8"    | 200x200 | F35 or 1/4" - 10'  | F35 or 6 - 3000 | F45 or 3/16" - 10' | F45 or 4 - 3000 | F60 or 1/8" - 10' | F60 or 3 - 3000 |
| 12" x 12"  | 300x300 | F35 or 1/4" - 10'  | F35 or 6 - 3000 | F45 or 3/16" - 10' | F45 or 4 - 3000 | F60 or 1/8" - 10' | F60 or 3 - 3000 |
| 16" x 16"  | 400x400 | F35 or 1/4" - 10'  | F35 or 6 - 3000 | F45 or 3/16" - 10' | F45 or 4 - 3000 | F60 or 1/8" - 10' | F60 or 3 - 3000 |
| 18" x 18"  | 450x450 | F45 or 3/16" - 10' | F45 or 4 - 3000 | F60 or 1/8" - 10'  | F60 or 3 - 3000 | F60 or 1/8" - 10' | F60 or 3 - 3000 |
| 24" X 24"  | 600x600 | F45 or 3/16" - 10' | F45 or 4 - 3000 | F60 or 1/8" - 10'  | F60 or 3 - 3000 | F60 or 1/8" - 10' | F60 or 3 - 3000 |
| 36" X 36"  | 900x900 | F50 or 1/8" - 10'  | F50 or 3 - 3000 | F60 or 1/8" - 10'  | F60 or 3 - 3000 | F60 or 1/8" - 10' | F60 or 3 - 3000 |

\* For non-square units, the tile size shall use the longest side dimension - TABLE 2

**TABLE 2**

Longest Side Tile Dimension

| Longest Side Dimension |                 | Grout Joint Size   |                 | Grout Joint Size   |                 |
|------------------------|-----------------|--------------------|-----------------|--------------------|-----------------|
| Inch                   | mm              | Inch               | mm              | Inch               | mm              |
| 1/4" or larger         | 7 or larger     | 3/16"              | 4               | 1/8"               | 3               |
| up to 16"              | up to 400       | F35 or 1/4" - 10'  | F35 or 6 - 3000 | F45 or 3/16" - 10' | F45 or 4 - 3000 |
| from 16" to 36"        | from 400 to 900 | F45 or 3/16" - 10' | F45 or 4 - 3000 | F60 or 1/8" - 10'  | F60 or 3 - 3000 |
| 36" and over           | 900 and over    | F60 or 1/8" - 10'  | F60 or 3 - 3000 | F60 or 1/8" - 10'  | F60 or 3 - 3000 |

## TILE

### Types

Tile includes mosaic, quarry, glazed, glass, decorative, porcelain and stones that have a thickness of less than 19 mm which are normally installed by adhering to a substrate. For stones 19 mm or greater refer to the latest TTMAC Dimensional Stone Guide.

In early 2012 the CAN/CGSB 75.1-M88 was withdrawn. The Terrazzo Tile and Marble Association has decided to adopt the ISO 10545 standards complimented by ASTM standards for missing topics. The ISO 10545 is written for ceramic tile only and does not include mosaics or stone tile. The TTMAC Manual covers all tile using ISO standards where available and ASTM standards for the balance.

### Ceramic Tile

ISO 13006 is the International Standards Organization's manual for ceramic tile excluding mosaics, specialty items and trim fittings. The standard categorizes a tile by its forming method, either pressed or extruded, plus it's water absorption. There is a further subcategory for extruded tiles as to whether they are natural or precision. The results are 12 categories, each assigned a chart which will define acceptable tolerances for the tile. In order for a tile to be ISO compliant, it must meet all of the criteria in the test summary chart. Unlike the ASTM, the ISO standards stipulate the performance criteria for each tile category. Complete listings may be found in ISO 13006. The tests themselves may be found in ISO 10545-1 through 10545-12.

The following information is required in order to determine to which standards a tile will be governed:

|                |            |                     |                       |             |
|----------------|------------|---------------------|-----------------------|-------------|
| Forming Method | a) pressed | b) natural extruded | c) precision extruded |             |
| Absorption     | a) <0.50%  | b) 0.50- 3.00%      | c) 6.00-10.00%        | d) > 10.00% |

Other highlights of the ISO 13006

The ISO 13006 requires clear indication by the manufacturer, for example, on the following:

- 1) Country of origin must be stamped on each tile
- 2) Only first quality tiles will be compliant and the box must be so labelled
- 3) Manufacturers must disclose whether a tile is glazed or not or whether it has been treated after production.

ISO does not cover trim pieces.

ANSI A137.1, Table 6 provides technical performance levels for mosaic tile and mosaic trim.

### Porcelain Tile

ANSI A137.2 — Tables 5-7 provides technical performance levels for glass tile

ANSI A137.3 — Tables 2-5 provides technical performance levels for gauged porcelain tiles and panels

#### Definitions:

Porcelain tiles are made from fine quality clays that allow for a range of colours and patterns. Fired in a fast fire kiln, they have absorptions of less than 0.5% (MR1) and are normally frost resistant. Shading and sizing is more easily controlled and larger sizes are increasingly popular.

Many tiles can be rectified to ensure minimal sizing tolerances of less than 1 mm, allowing for more uniform grout joint.

#### Types:

- Homogeneous tiles are colour through body; where the colour and pattern are created with the clays and run throughout the entire body of the tile. They may be polished or honed, unglazed or enhanced.
- Through body tiles have the colour running throughout the body but the pattern does not. The pattern is often created with silk screens or digital ink imprinting. This application may or may not include glazes.
- Double pressed tiles are when the clay is pressed twice, once to achieve the pattern and the second to create the back of the tile without the pattern.
- Glazed porcelain: Where colour and pattern are achieved with glazes and the body of the tile may or may not have a similar colour. In order to achieve porcelain status, the tile must have absorption of less than 0.5% \*.

#### Finishes:

- Porcelain tiles are hard and can be finished like stone; to a honed or polished. These finishes are mechanically ground after firing however tile may also be pre-honed prior to firing.
- Treated surfaces are usually created by applying a surface to the tile prior to firing. These treatments may improve cleanability, enhance colour or create a soft shine however they do not usually contribute to the colour or pattern.

### Thin Ceramic Tile Panels

- Before 2017, there were no standards for both the performance and the installation of what was known at the time for the new type of large format (i.e. 1000 mm x 3000 mm), (or even 1500 mm x 3000 mm) porcelain tiles which were 6.0 mm thick or less. They were also called “ Slim Tile”, Reduced Thickness Porcelain Tile”, and “ Thin Porcelain Tile” but as of 2017 there are now two official terms “American National Standard Specifications for Gauged Porcelain Tiles and Gauged Porcelain Tile Panels/Slabs” which falls under ANSI A137.3.
- Ceramic wall tile: While these have been on the market for many years, the latest technology has large format wall tiles (i.e. 300 x 1200 mm) in thickness of less than or equal to 5.5 mm.
- Pressed Porcelain: These tiles are usually limited to tile sizes (up to 600 x 1200 mm) and less than or equal to 5.5 mm in thickness. Some adhesive companies offer specialty adhesives so that these products may be used on the floor as well as the wall in both new and tile over tile applications. The Robinson Floor Tester can verify a tile’s suitability for a given application however full coverage of 95-100% is required to support thin tile in a flooring application.\* The minimum thickness for floor applications is 5.5 mm. In all cases verify with the manufacturer’s recommendations.
- Gauged Porcelain Tile Panels/Slabs are produced in large slabs currently up to 1524 x 3600 mm in thickness less than or equal to 5.5 mm. These slabs are somewhat flexible and can be held in place in a curve or installed flat. Currently these slabs are rated for wall applications although they have many additional uses such as furniture, countertops, exterior wall and ceiling applications. Usually the thinner slabs are available with an optional mesh for easy handling, as they tend to be fragile. Many slab manufacturers offer mechanically fastened systems for use in exterior cladding.

\* The use of Gauged Porcelain Tiles and Gauged Porcelain Tile Panels/Slabs is a relatively new application for these materials and there are some exceptional challenges with these types of tiles. Things that have to be considered are levelness of the floor maximum 3 mm in 3000 mm, coverage of mortar to the tile should meet the requirements of ANSI A108.19 which is extremely difficult to attain and is crucial for load bearing capability. Edge protection as well as movement joints are also challenging aspects of these materials on floors. In all specialized tools, equipment, thin-bed mortar and training are required for the proper installation of these products.

Lastly, the TTMAC does not recommend these tiles on a wood substrate until the industry has done enough R&D to determine that these products can survive on this substrate and other bending, deflecting substrates. TTMAC has not yet been able to assess the suitability of this tile for flooring use in this format, and as such has not developed any installation detail for wood frame construction. Consult manufacturer for all substrate, performance and installation criteria as well as warranty coverage.



Please refer to page 7.

### Trims

Trim units of various shapes, consisting of such items as: covebase, caps, corners, mouldings, interior and exterior angles, bullnose, curb units and stair treads, are available to achieve an installation of the desired sanitary and/or architectural design. Special slip resistant inserts, as well as prefabricated transition strips for use in interior and exterior corners to achieve a more finished appearance, are available. Specifier must indicate if these special trim units are required as their use will have an impact on the price of the tile installation.

- Bullnose - rounded edge which returns tile back to the substrate.
- Cove Base - a slightly rounded 90° return which allows a wall tile to flow into a floor tile. Used where sanitary conditions are required as it allows for easy cleaning.
- Step treads have either a bullnose or full return and may or may not have raised or grooved treads to increase slip resistance.
- Angle beads are ¼ rounds used to cover an exterior corner.
- Internal angles are ¼ rounds used to cover an internal corner.
- V-caps are raised returns used to create a counter top nosing.
- Also refer to ANSI A137.1.

## CERAMIC TILE NOTES FOR THE SPECIFIER

### Selection

Selection should be based on the specific environment taking into consideration, traffic and other exposure, safety (slip resistance), desired longevity, suitability of a tile size given substrate tolerances and maintenance concerns. For exterior use, only frost resistant tile should be used. Water absorption is not indicative of freeze thaw stability and separate tests are required or verify with manufacturer to determine suitability in an exterior environment.

In areas where slip resistance is required, special slip resistant tiles are available, however these tiles will likely be more difficult to clean or maintain.

Special consideration may be required when grouting slip resistant tiles such as but not limited to sealers or grout release products otherwise grout residues may have to be removed by special equipment and chemical products. Always ask for mock ups to be performed with the specified tiles and grouting products to confirm desired results.

Carborundum tiles are less common, however, it should be noted whether the carborundum filings run throughout the body of the tile or sit on top. Typically applied products are more vulnerable to wear.

Refer to the testing section for available tests.

Tiles will either have a manufactured edge which is slightly eased or a cut and rectified edge which is mostly square. Verify with the manufacturer for edge options.

## Stone Tile

Natural Stone Tile – includes granite, marble, travertine, slate and limestone. Each material has its own unique physical and technical characteristics. ASTM standards have been developed to better assess the suitability of each type of stone for a particular application.

Granite – Typically granular in appearance, granite is an igneous rock primarily composed of feldspar, quartz and smaller ferromagnesium materials. Many types of granite are resistant to mild chemical attacks and rock salt. Due to its commonly dense physical make-up, many types of granite are suitable for exterior applications where freeze-thaw conditions exist. Refer to ASTM test methods for standards.

Limestone — is layered and formed in ancient sea beds from the skeletons and shells of sea creatures that lived in warm seas millions of years ago. It will often contain seashells and fossils embedded in the surface. It is a unique natural stone and at times, contains visible mysteries of our past within.

Limestone is a calcareous stone which means it will react negatively to acidic substances such as vinegar, wine, lemon juice and even some cleaning products. The stone reacts negatively to acids by etching, dulling or showing rings.

Limestone is divided into 3 categories Type 1 (Low density), Type 2 (Medium density), and Type 3 (High density).

Marble – A metamorphized limestone that contains calcite, dolomite and is capable of being polished. Marbles have a wide variety of densities and abrasion resistance and are susceptible to chemical attack and the possibility of staining. The MIA classifies marbles into four groupings – A,B,C, and D. This classification system is based on a particular material's working capabilities and not necessarily the quality of the stone. This relates to soundness with group "A" having uniform and favourable working qualities. Group "B" may have natural faults, some filling may be necessary. Group "C" and "D" may require additional reinforcement. A marble is a calcareous stone which means it will react negatively to acidic substances such as vinegar, wine, lemon juice and even some cleaning products. The stone reacts negatively to acids by etching, losing its sheen/polish or disintegrating. Some natural stones react adversely to moisture and therefore epoxy setting may be required. Polished marble used on floors will scratch and show wear patterns. Honed finish is a preferred finish for interior floors.

Travertine – A "sub-category" of limestone that originates from hot springs. A primary characteristic of many travertines is the voids which are present. These voids are often filled with epoxy, polyester resins or Portland cement based products. Many travertines can be polished and are commercially referred to as marble.

Slate – A metamorphic rock that is known for its naturally occurring cleavage lines. Typically earth-tone colour in nature. Not all slates are suitable for exterior applications. Refer to ASTM test data.

## Surface Finishes

There are various different surface finishes that are available for natural stone. Listed below are some of the more common finishes available. Some surfaces finishes are more conducive to certain stones due to their densities and mineral content. Specify the desired finish for the tile face and all exposed edges.

Polished – A high gloss finish that is achieved by the grinding of the materials surface with fine grit abrasives. Polished finishes are highly reflective and depending on the material may accentuate surface inclusions and variations.

Honed – A mat finish that is achieved by the grinding of the surface with fine grit abrasives. This type of surface finish is achieved through lower grit abrasives than that of a polished finish. Honed finishes typically achieve higher slip resistance readings than a polished finish.

Flamed (Thermal) – A surface finish that is more commonly associated with granite pavers. This process involves the surface of the material being exposed to high thermal temperatures where the softer minerals are removed resulting in an undulated surface. The rougher surface texture often mutes the colouration of the stone and increases the slip resistance of the material. Due to varying densities of stone this type of finish may not be conducive to certain stones and thicknesses.

Water Jet – Similar to a flamed texture with a more honed appearance. Waterjet also refers to precision cutting, etching and engraving.

Tumbled – This finish is achieved using large tumblers that may include the use of some acids within the drum to roughen and/or "distress" the appearance of the stone. This decorative type of finish is more commonly applied to softer stones (marble and limestone).

Brushed – Similar in appearance to honed, however the use of polyester brushes leaves a slightly undulated surface.

Natural Cleft - This type of surface finish is mostly found with slate. The surface finish is a result of the natural occurring lines of separation of the stone and is achieved through splitting of the stone at its natural fault lines.

## Stone Tile Selection

Select stone on the basis of manufacturer's recommendations or on the basis of proven performance under similar conditions of use. In evaluating suitability of stone, refer to following requirements:

|                     |                        |
|---------------------|------------------------|
| ASTM C615 Granite   | ASTM C616 Quartz-based |
| ASTM C568 Limestone | ASTM C1526 Serpentine  |
| ASTM C503 Marble    | ASTM C1527 Travertine  |
| ASTM C629 Slate     |                        |

## STONE NOTES FOR THE SPECIFIER

Specify the edge detail to be straight cut or eased. Natural stone is usually sold with a gauged thickness with the exception of some slates. Gauged stones have a minimum tolerance for thickness and may be installed using a thin-set method of installation. Stones that are un-gauged may require a Large & Heavy Tile mortar or full mortar bed installation system. Verify with the supplier as to whether the stone is gauged or not prior to installation.

For safety in exterior walking areas, polished stone should not be used and honed finish should be used with caution.

For exterior applications, coarse textured, sandblasted or thermal (flamed) finished stone is recommended. Verify with the supplier as to the suitability of the selected stone for an exterior application. The type of edge finish should be specified by the consultant.

When specifying stones with varying degrees of hardness for use in a pattern, note that the material will not wear at the same rate. The use of sealers and other chemical stone products may react differently to each type of stone, special precautions may be required during restoration.

Vertical applications can use any finish, however, polished finish on most marbles and limestones may not last on exterior applications.

On interior flooring applications, polished stone will show wear patterns in traffic areas. Honed finishes will show less wear patterns and should be recommended for interior flooring use.

For stone tile with any edge longer than 380 mm, the surface variation should not exceed 3 mm in 3000 mm nor more than 1.5 mm in 600 mm).

Prior to the grouting of the natural stone ensure that the colour of the grout selected does not stain the stone. Due to the natural absorbing characteristic of most natural stone it is advisable that onsite testing be carried out to determine if staining from pigmented grout and mortars is prominent. Lighter coloured stones may require the use of "white" mortars to avoid "bleeding" of pigments through the stone. When possible, natural stone should be grouted with similarly shaded pigmented grouts. Sealing of the stone prior to grouting may be required to effectively reduce the stone's porosity.

Specify the exact facial dimensions and thickness. Note where stone sizes are to be modular and deduct the joint from the finished size.

Specify straight cut or eased/beveled edges for all stone tiles.

## OTHER CONSIDERATIONS FOR SPECIFYING TILE (all types)

- a) Tile selection should be based upon service requirements. Glazed floor tile is most used in residential or light commercial applications. Stone, quarry and porcelain tile are normally used in commercial and heavy traffic areas.
- b) In areas where slip resistance is required, special slip resistant tiles are available, however, these tiles may be more difficult to clean or maintain.
- c) Slip resistant tiles and some unglazed tile may be prone to staining by pigmented grouts. It is recommended that all unglazed tile be tested with the grout that will be used prior to installation to determine whether staining will be a problem. Staining can be minimized by selecting grout colours close to the colour of the tile or by use of appropriate sealers on the tile prior to grouting. For further information refer to the latest TTMAC Maintenance Guide.
- d) LIGHTING — Where the ceramic tile, marble or granite surfaces are exposed to natural or artificial light at a shallow angle almost parallel to the tile surface, normal inconsistencies in the surface may be highlighted by shadows. To avoid this shadowing effect, avoid the use of lights mounted on the wall and locate ceiling fixtures at least 600 mm away from the wall and preferably in the centre of the room. Installing permanent or temporary lighting that simulates the planned lighting schematics prior to the tile installation may identify potential problems and may allow for some adjustments during the installation to minimize or eliminate shadows.

- e) MAINTENANCE — Refer to TTMAC Maintenance Guide.
- f) CHEMICAL RESISTANCE — Where improved chemical resistance is required, tile can be set and grouted with furan or epoxy setting and grouting materials. These materials are shown as acceptable alternatives throughout this manual where appropriate. Refer to the manufacturer's product data sheets for details concerning resistance to specific chemicals and/or chemical groups.
- g) ENVIRONMENTAL CONSIDERATIONS — Ceramic tile, marble, granite and terrazzo are environmentally safe materials that do not pose any hazards in use. The setting materials used with these products are generally low hazard materials that, when cured, do not cause any environmental concerns. Portland cement based products are alkaline and workers should avoid skin contact with all setting and grouting materials. Manufacturer's recommendations should be followed.
- h) CHANGES IN LEVEL — Specify thresholds to adjust between adjacent finish floor levels when substrate cannot be depressed. Changes in level up to 6 mm and 13 mm shall be bevelled with a slope no greater than 1:2. Changes in level greater than 13 mm shall be accomplished by means of a ramp. The least possible slope shall be used for any ramp. The maximum slope of a ramp in new construction shall be 1:12.
- i) Sealers or Protective Coatings (all type of tile) — Follow manufacturer's recommendations for sealing. The word sealer is often misused. A sealer will coat the tile and become the wear layer. It might consist of urethane, varethane or wax. Sealers will require periodic re-application which should be covered in the maintenance data sheets.
- j) Breathable, penetrating sealers do not coat the surface completely. They may provide some improved cleanability and may also improve the slip resistance of the floor, however, check manufacturers' data to determine the limitations of the product such as protection from staining or damage from de-icing salt or corrosive products.

## INSTALLATION NOTES FOR THE SPECIFIER

### Size Tolerances for Tile and Grout Joint Selection

Prior to specifying grout joint sizes, determine the facial dimension tolerance of the tile.

Minimum joint sizes for unsanded wall grout are 1.6 mm.

Minimum joint sizes for sanded floor grout are 3 mm.

Prior to specifying grout joint sizes, determine the facial dimension tolerance of the tile.

Generally, most wall tiles will have less than 1 mm tolerance and so a 1.6 mm tile joint may be used. All other tiles and stones may vary according to manufacturer/producer's standards for production and sorting.

To achieve a 3 mm grout joint, tile sizes should not vary by more than +/- .5 mm

To achieve a 6 mm grout joint, tile sizes should not vary by more than +/-1.5 mm

Rectified tiles generally have sizing tolerances of approximately +/- .8 mm and can therefore be installed with a tighter grout joint. When specifying floor joints of less than 3 mm, seek manufacturers recommendations for suitable grout. Butt joints are not recommended for the following reasons:

- Does not allow for expansion and contraction of the substrate (i.e. movements due to thermal conditions and curing, etc.)
- Does not effectively address size variations of tile
- May contribute to moisture penetration resulting in mold and mildew growth
- Does not allow for proper installation when substrate may be uneven.

### Tile Lippage

Lippage is a condition where edges of adjacent tiles are not installed at the same level. Lippage, or its perception, may be influenced by many factors including:

- A) Installation of tile by thin-set method on a surface which exceeds the permissible substrate surface variation.
- B) Failure to properly beat the tile into position on a fresh mortar bed.
- C) Allowable manufacturing variation in thickness and warpage of the installed tiles.
- D) Naturally occurring warpage in materials.
- E) Setting ungauged stone without notch back trowelling through a screed or push box.
- F) Size of joints between installed tiles.
- G) Angle of natural or artificial light which creates exaggerating shadows across the surface of the tile.

ANSI A137.1 establishes limits for allowable warpage in manufactured tile and needs to be taken into account when considering lippage. The following chart is a guideline for identifying acceptable lippage in tile installations in addition to the inherent warpage of tile manufactured in accordance with ANSI A137.1 and ANSI A137.3.

| TILE TYPE               | TILE SIZE                          | JOINT WIDTH              | ALLOWABLE LIPPAGE* |
|-------------------------|------------------------------------|--------------------------|--------------------|
| Glazed Wall/Mosaics     | 25 mm x 25 mm to 150 mm x 150 mm   | 1.5 mm to 3 mm           | .78 mm             |
| Quarry                  | 150 mm x 150 mm to 200 mm x 200 mm | 6 mm or greater          | 1.56 mm            |
| Pressed Floor/Porcelain | All                                | 1.5 mm to less than 6 mm | .78 mm             |
| Pressed Floor/Porcelain | All                                | 6 mm or greater          | 1.56 mm            |
| Gauged Porcelain        | All                                | 2 mm to 3 mm             | .78 mm             |

\*Values to be added to the actual measured tile warpage.

Notes:

Some manufacturers may recommend for wider grout joints

On floors where slope to non linear drains are present, the amount of lippage which will occur may exceed these limits, especially when tile sizes are 150 mm x 150 mm or larger are used. Lippage will be greater when tile sizes are larger. The use of smaller module tile on floors which are sloped to non linear drain units will help reduce lippage. The use of linear drains will allow use of larger size tile without lippage.

### Deflection

All floor systems, including wood frame construction and sub-floor panels, over which the tile or stone is installed, shall be in conformance with the National Building Code and/or the Provincial Building and/or the local Building Codes.

\*Note: The owner shall communicate in writing to the project design professional and general contractor the intended use of the tile installation, to enable the project design professional and general contractor to make necessary allowances for the expected live load, concentrated loads, impact loads, and dead loads including weight of the tile and setting bed. The tile installer shall not be responsible for problems occurring from any flooring or subfloor installation not compliant with applicable building codes, unless the tile installer or tile contractor installs the floor framing or subfloor. The general rule is for a tile installation the maximum allowable deflection criterion is L/360 (unless if any one side is longer than 380 mm use Stone recommendation) and for Stone maximum allowable deflection criterion is L/720. Consider dead loads such as but not limited to kitchen islands that may invite creeping of the wood structure over time which could result in tile cracking or debonding around the island. Additional support or means of weight distribution should be considered.

\*The preceding was re-written with the consent of the TCNA (Tile Council of North America).

### Exterior Tile Cladding

Tile cladding of buildings may be accomplished by the following methods:

- a) Direct bonding to a solid concrete or cementitious backer unit substrate.
- b) Shop fabrication of cladding panels usually consisting of cementitious backer units attached to metal studs with tile bonded to the cementitious backer units with a latex-Portland cement mortar.
- c) Large sized porcelain tile (currently up to 1600 mm x 3200 mm) mechanically attached to a metal framework fastened to the wall. The method of attachment must be approved by the manufacturer of the tile and design should be approved by the consultant.
- d) Tile may be bonded directly to a solid substrate up to 3000 mm above the top of the foundation wall.
- e) For mechanically fastened stone cladding refer to the latest edition of the TTMAC Dimensional Stone Guide.

Regardless of the method of construction, the following criteria must be met:

1. Movement joints must be provided as per detail 301MJ-2025.
2. Where tile is bonded to a substrate, every effort must be made to achieve 95% contact and preferably up to 100% contact between the setting material, the substrate and the tile. Full contact is achieved more readily when applying tile to shop fabricated cladding panels and/or when applying smaller sized tile.
3. Proper flashing must be used to prevent water ingress behind the tile. Weep holes should also be considered as part of the design.
4. The final installation must be able to withstand all design loadings in accordance with the national and local building codes. Direct bonding of tile to a solid substrate should be approached with caution when cladding height exceeds 3000 mm since bond failure could endanger pedestrians. Installation systems above 3000 mm must be designed in consultation with the tile cladding and the adhesive manufacturer and should be guaranteed by them to perform as intended. Proper design, workmanship and proven materials are required for successful installations.

## Exterior Tile Floors & Decks

Tile installed on horizontal surfaces may be installed in accordance with Details 310F-2025, 311F-2025 or 325ED-2025 with the following recommendations:

- a) Provide expansion and control joints as per Detail 301MJ-2025.
- b) Slope slabs and finished tile surface to provide complete drainage and prevent water accumulation on the surface.
- c) Use tile classification Type MR1 having good freeze-thaw durability, see page 7.
- d) Use suitable latex additives in mortar beds, bond coats and grout. When a latex additive is to be used, a minimum cure of 14 – 60 days is required before exposure to moisture. Verify with manufacturer the correct cure time required. Alternatively, to reduce curing time required, a rapid set mortar may be more suitable.
- e) Over occupied areas or non-occupied decks or balconies that are not flow through, use suitable certified roofing membranes with a drainage layer over the roofing membrane.
- f) For slabs on grade, concrete shall have air entrainment of 5% to 8% and provide suitable drainage below slabs.

## Installation of Agglomerate Marble, Terrazzo, Tile & Dimensional Stone (such as granite, marble, and slate)

These materials can be set by any of the methods used for installing tile. However, most agglomerate marble should not be used on exterior surfaces unless recommended by the manufacturer. Dimensional stone with a hardness (Ha) of 10 or more are suitable for use as flooring (ASTM C241). A minimum abrasive hardness of 12.0 is recommended for commercial and other heavy traffic areas. Light coloured marble tile should be installed with a white latex cementitious thin-set mortar to prevent shadowing or discolouration due to setting materials. Certain marbles such as Rosso Levanto, green marble, some green slate and agglomerate tile have a tendency to warp and curl when installed with bond coats that contain water. These materials generally have to be installed with a 100% solids epoxy mortar. When installing granite or agglomerate marble tile, the bond coat should be a latex cement slurry, a Portland cement mortar, 100% solids epoxy mortar or modified epoxy emulsion mortar.

When installing slate or marble tile on floors, attempt to achieve full contact with the bond coat to prevent cracking of tile under traffic loading. When installing ungauged materials, notch back trowel through a push box or box screed to compensate for variations in material thickness or wet set installation as ANSI A108.1A. Install granite, marble or agglomerate tile with 1 mm to 3 mm width joints and grout with a non-sanded latex-Portland cement grout. Terrazzo and slate tile may be installed with joints from 3 mm to 6+ mm and may be grouted with latex-Portland cement grout. Some terrazzo tile may require grinding after installation. Allow adequate cure of bonding material before grinding terrazzo tile (minimum 3 days at 20°C and 7 days at 10°C is recommended).

## INSTALLATION MATERIALS

### Setting Materials - Adhesives and Mortars (Notes for the specifier)

The same materials may be used for installing ceramic tile, natural stone agglomerate and terrazzo with the following exceptions:

- White latex cementitious thin-set mortars are recommended for light coloured limestones and marbles to prevent staining and shadowing. Cement substrates should also be tested for moisture not to exceed 1.36 kg/9.3m<sup>2</sup> to avoid Portland staining or damage.
- Epoxy setting (100% solids) is recommended for use with certain stones such as Rosso Levanto, green marble, some green slates and some agglomerate tiles that may have a tendency to curl when set with mortars containing water.
- Latex-Portland cement mortar will improve adhesion of porcelain tile and flat back and notch back trowelling will assist in achieving higher bond strengths.
- Glass tile requires the use of specialized thinset mortar to avoid discoloration and provide adequate bonding.
- When tile are set by the thin-set method on exterior surfaces, in a areas subject to heavy loads, in wet areas or for tile with any edge longer than 380 mm that are going to be subjected to heavy load impact, a minimum of 95% coverage must be achieved. The bonding material must be notched in horizontal straight lines. Set tile on the freshly notched thin-set mortar, slide tile back and forth at 90° to the notches. This method can produce maximum coverage, with the corners and edges fully supported.
- Flat back and notch back trowelling may be necessary to achieve a minimum of 95% coverage when installing tile with any edge larger than 300 mm Flat back and notch back trowelling also improves adhesion to tiles with bond breakers such as dust, kiln release agents and dirt, as well as tile with a raised or textured back. Flat back trowelling involves application of a thin trowelled coat to the back side of the tile using the flat side of the trowel immediately before setting the tile.
- Wipe the backs of all stone tiles with a damp cloth to remove the dusty film that can prevent the adhesive from bonding to the tile.
- Immediately prior to setting ungauged slate, marble, stone or large sized ceramic, tile must be flat back and notched back trowelling through a push box or box screed to achieve a uniform thickness of tile and mortar combined.
- Tile must always be set while bond coat is wet and tacky and has not skinned over.

Mortar Bed - A mixture of Portland cement, sand and water installed to a thickness as required to provide a flat substrate on which to apply tile. When a latex additive is to be used a minimum cure of 14 – 60 days is required before exposure to moisture. Verify with the manufacturer the correct cure time required. Alternatively, to reduce curing time required, a rapid set mortar bed may be more suitable. It may be accurately sloped where required and can be used to correct irregularities in sub-surface planes. On floors, mortar beds may be reinforced with 51 mm x 51 mm x 1.6 mm gauge galvanized or stainless square wire mesh and on walls with expanded metal lath weighing not less than 1.4 kg/m<sup>2</sup>. Where expanded metal lath is used, a scratch coat is normally applied before the mortar bed is applied.

### Types of Installation Systems

12 mm - 26 kg/sq.m. Mortar for large and heavy tile  
25 mm - 52 Kg/sq.m. Mortar for large and heavy tile  
38 mm - 80 kg/sq.m. Mortar Bed Bonded system  
50 mm - 105kg/sq.m. Mortar Bed Bonded system  
63 mm - 132kg/sq.m. Mortar Bed Floating system

Approximate weights for underbed mortar installation (weight of mortar only). Weight may vary depending on sand, aggregate size and mix percentage of sand/cement/water.

Dry-Set Mortar (ANSI A118.1) - a mixture of Portland cement, sand and water retentive additives which is used as a bond coat for setting tile over cured mortar beds, masonry, concrete or on other suitable backings which are plumb and true.

Latex-Portland Cement Mortar (ANSI A118.4)

- A: A two-component liquid latex mixed with factory blended dry-set mortar. Both components must be compatible or supplied by the same manufacturer. Used as a bond coat for setting tiles on all surfaces listed under dry-set mortar, cementitious backer units and coated glass mat backer boards. Certain products may be suitable for installation over plywood on floors and existing ceramic tile. Recommended for heavy-duty and extra heavy-duty installations, exterior installations and hard to bond tiles such as porcelain or slate in high traffic areas.
- B: A single component mix incorporating a redispersible dry latex in a bag, generally referred to as “Polymer Modified Mortar”, generally recommended for moderate, light commercial and residential use. Some high-latex content polymer modified mortars may be suitable for heavier use. Manufacturer’s recommendations must be followed.

Latex-Portland cement mortars may require 14 – 60 days cure before exposure to water. Verify with the manufacturer the correct cure time required. Alternatively, to reduce the curing time required, a rapid set mortar may be more suitable. The formulation of latex additives varies substantially and the manufacturer’s directions and recommendations should be followed explicitly. Always compare physical properties when writing multiple choice specifications or accepting equivalents.

Exterior Grade Plywood (EGP) Latex-Portland Cement Mortar (ANSI A118.11)

A modified Portland cement dry-set mortar to which a polymer has been incorporated in liquid latex form or in a powder form for the bonding of tile to floors over exterior grade plywood in interior dry or limited water exposure areas only. When added in liquid latex form it is added as a replacement for part or all of the gauging water in accordance with the manufacturer’s instructions.

Lightweight Mortars (ANSI A118.4 AND A118.11)

Lightweight mortars are polymer-modified, premium-grade, non-sag lightweight mortars, for thin or medium bed installations. The lightweight characteristics both in the powder and the resulting mortar provide advantages such as ease of handling and application, superior coverage and excellent sag resistance. Lightweight mortars are used in wall, floor and ceiling installation of marble, slate, granite, pre-cast terrazzo, agglomerate, porcelain tile, and most types of ceramic and stone tile on properly prepared substrates of concrete, masonry, cement terrazzo, concrete backer units, existing surfaces of ceramic or stone tiles, or, in dry areas only, on exterior grade plywood on floors. They are also used in lieu of mastic adhesives for tile in shower, bathroom and backsplash installations.

Dry-set Mortar for Heavy and Large Tile: (ANSI A118.1)

A cementitious dry-set mortar specifically formulated for direct bonding of ceramic tile and stone that exhibits reduced shrinkage and higher support compared to traditional dry-set mortars, which also allows for use in thicker bond coats from 2.4 mm and 12.7 mm in thickness after the tile is embedded. These mortars are not designed to be used for trueing or leveling underlying substrates such as unlevel concrete.

Modified Dry-set Mortar for Heavy and Large Tile (ANSI A118.4)

A cementitious latex-Portland Cement mortar specifically formulated for direct bonding of Ceramic Tile and Stone that exhibits reduced shrinkage and higher support compared to traditional dry-set mortars. They also allow for use in thicker bond coats from 2.4 mm to 12.7 mm in thickness after the tile is embedded. These mortars are not designed to be used for trueing or leveling underlying substrates such as unlevel concrete.

#### Improved Modified Dry-set Cement Mortar (ANSI A118.15)

A tile-setting mortar that is designed to improve adhesion, reduce water absorption, and provide greater bond strength and resistance to shock and impact. Additives allow some latitude in working time, working conditions and temperatures.

#### Improved Modified Dry-set Mortar for Heavy and Large Tile (ANSI A118.15)

These improved mortars are designed for the following: improved adhesions, reduced water absorption, greater bond strength and increased resistance to shock and impact. They exhibit reduced shrinkage and higher support compared to traditional improved modified dry-set mortars which allows for use in thicker bond coats from 2.4 mm to 12.7 mm in thickness.

#### Cementitious Self-levelling Mortars (ANSI A118.16)

Cementitious self-levelling mortars consist of special cements mixed with synthetic resins and additives. When mixed with water, a fluid, self-levelling mortar is produced which can be applied from a feather edge up to the required thickness in fewer operations. High-performance self-levelling cementitious flooring compounds permit a good working time, followed by rapid hardening, thereby allowing walk-on access and light traffic within two to three hours. They can incorporate rapid-drying characteristics, allowing ceramic tile, stone and various floor coverings to be applied within 24 hours. In residential, office or industrial construction, self-levelling flooring compounds are applied at various thicknesses depending on the product. In most cases, a primer is recommended to improve adhesion, limit water absorption from the flooring compound into the base and prevent air leakage into the screed and surface bubbles. For small surface areas, the material is hand-applied but for larger floors (greater than 1000 m<sup>2</sup>) a pumpable material has many advantages. The unique reaction of special cements used enables formulations to be produced that are shrinkage-compensated. Thanks to the reduced tension and strain in the hardened floor, the surface is less susceptible to cracking and de-bonding. Flexural strength and toughness are not compromised by the speed of the process, and the resulting surface finish provides a high compressive strength underlayment, for use in heavy commercial applications, certainly suitable for tile and stone installations. Consult and follow manufacturer's product recommendations for the product being used.

#### Full Contact Mortars (ANSI A118.4 AND A118.11)

Full contact mortars are single component, high performance, polymer modified mortars that are used in thin-bed and Large and Heavy Tile Mortar applications specifically designed to achieve the required coverage of bonding mortar to large format or heavily lugged tiles. Superior wet-in characteristics provide outstanding backing transfer and may eliminate the need for flat back and notched back trowelling. Although the resulting mortars are more fluid, they support large format tile horizontally, holding trowel ridges well. They are available in regular-setting or fast-setting mortar versions.

#### Fast-Setting Mortars (ANSI A118.4 AND A118.11)

Fast-setting mortars allow for tile to be grouted and opened to light traffic within 3-4 hours of application, and for full service after 24 hours. They offer major advantages for tiling of surfaces that have to be ready for use quickly, such as shopping malls, existing industrial facilities, hospitals, airports, as well as for outlying area installations, where installers are required to complete installations within a limited time frame. Some mortars may need to have extended cure time before exposure to moisture, 7 – 14 days.

#### Epoxy Mortars (ANSI A118.3)

An epoxy resin normally filled with silica sand and combined with a hardener before application. Used as a bond coat where high bond strength and chemical resistance are required.

#### Modified Epoxy Emulsion Mortars (ANSI A118.8)

A three-component mortar consisting of emulsified epoxy resins, a hardener and blend of Portland cement and sand. Modified epoxy emulsion mortars give high bond strengths and are used for similar applications as latex modified Portland cement mortars. They are not designed for chemical resistance.

#### Furan Resin Mortar (ANSI A118.5)

A mortar consisting of carbon and/or silica filled furan resin and hardener used in applications where chemical resistance is required. May be used as the bond coat on fully cured surfaces as per details 310F-2019-2021 and 311F-2019-2021. Follow manufacturer's instructions regarding surface preparation and installation.

#### Improved Modified Dry-Set Mortars (ANSI A118.15)

Improved Modified Dry-set Cement Mortars (ANSI A118.15). These improved mortars are designed for the following: improve adhesions, reduce water absorption, greater bond strength and resistance to shock and impact. - See more at: <http://www.ttmac.com/en/specification-addendums.html#sthash.ZrhqQSPp.dpuf>

#### Organic Adhesive (ANSI A136.1)

A ready to use paste consistency adhesive in which the binder is an organic composition. They are normally either solvent based or water-based adhesives and cure by evaporation of solvent or water. For use on interior surfaces only where temperatures do not exceed 50°C. Not used for applications involving immersion in water. Water resistance and bond strength varies depending on type and product. Organic adhesives may require an extended cure period when used for large tile and are not recommended for use on floors.

SPEC NOTE: Select appropriate ANSI Materials Method for Installation Method.

| MATERIALS ANSI  | INSTALLATION ANSI     |
|---|-----------------------|
| ANSI A 118.1 Dry-set Portland Cement                                  | ANSI A108.5           |
| ANSI A 118.3 Chemical Resistant Epoxy                                 | ANSI A108.6           |
| ANSI A 118.4 Latex Portland Cement Mortar                             | ANSI A108.5           |
| ANSI A 118.5 Chemical Resistant Furan Mortar & Grout                  | ANSI A108.8           |
| ANSI A 118.6 Non-Modified Cement Grouts                               | ANSI A108.10          |
| ANSI A 118.7 Latex Portland Cement Grout                              | ANSI A108.10          |
| ANSI A 118.8 Epoxy Emulsion Mortar/Grout                              | ANSI A108.9           |
| ANSI A 136.1 Organic Adhesives  | ANSI A108.4           |
| ANSI A118.16 Cementitious Self-Leveling Underlayment                  | ANSI A108.21          |
| No ANSI Standard for Portland Cement Mortar Bed Materials             | ANSI A108.1 A, B or C |
| ANSI A118.15 Improved Modified Dry-set Cement Mortar and Installation | ANSI A108.5           |

## SPOT BONDING

### Introduction

The popularity of large size ceramic and stone products, in many different formats and thicknesses, coupled with the desire for smaller grout joints, brings increasing challenges to the installation community. Achieving durable and aesthetically pleasing installations of large tile requires greater knowledge of and adherence to standards by both the substrate and tile trades. This is often contrary to the perspective of the designer, specifier or end user who wrongly perceives fewer tile and smaller grout joints means the installation is less difficult. When the faulty perception of less or easier work is combined with accelerated construction schedules and tight budgets, unrealistic expectations often occur. The tile contractor often finds themselves under pressure to find a means of accelerating the installation schedule while still achieving a profit. This often leads the installer to employ the ill-advised practice of spot bonding. Spot bonding has NEVER been an approved installation method by the TTMAC

### The Issue

Historically floor and wall surface tolerance recommendations were 6 mm in 3000 mm with no more than a 3 mm variation in 300 mm. This worked well when tiles were smaller and the grout joint was commonly around 6 mm. However, that substrate recommendation often proves inadequate when using larger size tiles, such as those with any one side being 380 mm or more. Industry trends continue to include tiles in larger formats, in varying thicknesses and multiple size patterns with minimal grout width requirements. To address this, the ANSI and TTMAC Specification Guide Committees adopted new substrate recommendations for tile with a leading edge of 380 mm or greater that calls for 3 mm in 3000 mm with no greater than .5 mm variation in 600 mm. Narrow grout joints on large tile compound the need for floor flatness. The stringent tolerances under the ANSI revision are often beyond the technical capabilities of the typical concrete contractor. It then falls to the tile contractor to provide a suitable substrate for this product. Remediating the substrate to meet the tolerance requirements should be addressed by providing an appropriate allowance in the specification process, however this is often ignored. This financial dilemma often leads to the practice of spot bonding where dollops of mortar are used in lieu of an appropriate floor filler material, such as patches, mortar beds or self-leveling underlayments. This practice is done often in both wall and floor tile applications.



## Industry Coverage Requirements

The current mortar coverage standards have a lengthy history of providing long lasting serviceable tile installations. Spot bonding with mortar will not meet coverage requirements and will put the tile contractor at risk if a job failure occurs. Spot bonding has been reviewed and considered on a number of occasions in the past. Currently, there are no methods or standards that recognize spot bonding thinset mortar for either floor or wall tile installations. Spot bonding, whether used in conjunction with fully troweling the floor prior to applying the dollops or spots; or as is happening in increasingly alarming circumstances, when the spots are simply applied directly to the substrate without keying in the mortar or troweling it in, rarely provides the coverage required by manufacturer's recommendations and industry standards. It is also in conflict with the design of the products as defined under ANSI A118 thinset standards; which state "dryset mortars are designed as direct bond adhesives and not intended for truing or leveling substrates or the work of others." Additionally, spot bonding does not provide coverage as required under ANSI A108.5 which states "average contact area shall be not less than 80% except on exterior or shower installations where contact area shall be 95% when not less than three tiles or tile assemblies are removed for inspection." In addition, most Dry-set and Latex Portland Cement tile bond coat mortars are manufactured to only be approximately 3 to 6 mm maximum thickness when the tile is applied and the notches are flattened out. Higher thicknesses typically will have excessive shrinkage causing loss of bond and lippage. Other issues: Limited impact resistance, limited load resistance, low shear bond resistance, poor grout support, reservoir for moisture collection. There are some proprietary systems that are available from some manufacturers that have proven records for spot-bonding wall applications which usually involves an epoxy mortar. Verify that both the tile and setting system supplier/manufacturer approve of using such a method/product prior to installation.

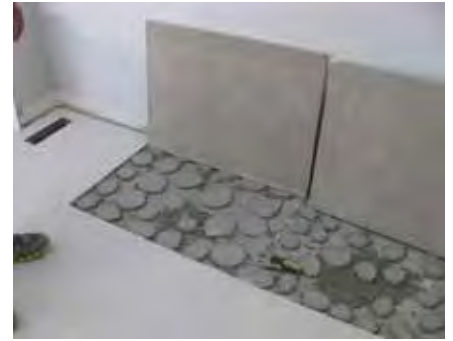
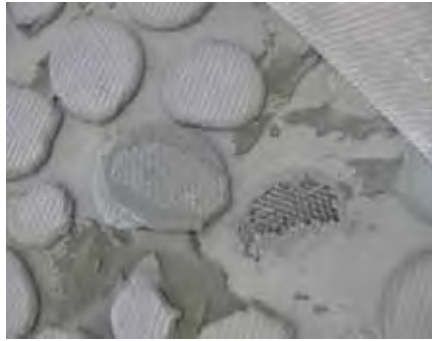

## **FLAT BACK-TROWELING & NOTCHED BACK-TROWELING (FORMERLY BACKBUTTERING & BUTTERING)**

The purpose of this document is to provide clarity to the new industry designations for applying adhesive to the backs of tiles and stone, commonly referred to as backbuttering or buttering. The terms backbuttering and buttering have taken on their own definitions in different parts of the country and have been mis-takenly associated with spot bonding. When these methods are used properly, they assist with ensuring mortar contact to the tile for proper adhesion. In the case of tiles with recessed patterns or rough profiles, flat back-troweling also assists with achieving required mortar coverage provided troweled ridges on a properly prepared substrate are completely collapsed.

### **Flat Back-Troweling is defined as:**

“The application – using the flat side of the trowel (keying in or burning in) – of a thin layer of modified/non-modified dry-set mortar (thin-set mortar) to the backside of ceramic, porcelain, glass and stone tile just before the tile is embedded into the still wet setting mortar.” (Note: When done correctly, the flat side of the trowel will make a scraping sound on the tile back as pressure is applied to the surface.) This was formerly known as backbuttering.

### **Notched Back-Troweling is defined as:**

“After flat back-troweling has been completed, additional modified/ non-modified dry-set mortar (thin-set mortar) is applied to the backside of ceramic, porcelain, glass and stone tile and uniformly combed in one direction with an appropriate notched trowel just before the tile is embedded into the setting mortar. (Caution: When notched back-troweling is used, the embedded thickness of the dry-set mortar bed cannot exceed ANSI, ISO or manufacturer requirements.) Formerly known as Buttering.

### **CAUTIONARY NOTES:**

- Using dry-set mortar/thin-set mortar to true or level the substrate is not recommended. Additional dry-set mortar/thin-set mortar when applied to the back of a tile is not a substitute for a properly-prepared substrate meeting flatness requirements for the specified tile, whether it be ceramic, porcelain, stone, glass, etc. It is used only to add mortar to fill irregularities of the tile underside and compensate for thickness variations of the tiles and promote increased bond strength.
- Notched back-troweling is not to be confused with the Box Screed Method of installation, which is discussed in Chapter 6: Specialized Installation Procedures in this Reference Manual.
- Neither flat back-troweling or notched back-troweling should be construed in any way to allow spot bonding of tiles. When mortar is notched to the tile back, the ridges must be collapsed when placed to create adequate coverage.

### **FLAT BACK-TROWELING**

Flat back-troweling tiles, as stated in the ANSI standard (A108.5.2.3.5) – is listed as an option to achieve the desired coverage. Flat back-troweling may help with coverage, but it will not provide the necessary coverage for an installation by itself. The other option listed in the standard to achieve the needed coverage is to “select a notched trowel sized to facilitate the proper coverage.” Selecting the properly sized notch trowel to achieve the needed coverage for an installation is a key requirement for any properly installed installation.

Flat back-troweling can, however, promote increased bonding strength of the bond coat material. By spreading the thin layer of bonding material to the back of the tile, the bonding material is now forced into any surface voids of the tile. The tile should be installed and embedded in a properly-prepared notched surface while the mortar is wet, ensuring the wet transfer of the mortar. This increases the bond strength as the flat back-troweling has increased the contact of the bonding coat material to the back of the tile versus a tile that was not flat back-troweled.

Another suggested use of flat back-troweling tiles is to fill voids in the patterned backs of tiles that often occur in the manufacturing process. By filling in the voids, the back plane of the tile is now more uniformly flat, allowing the notched ridges of dry-set mortar/thin-set mortar in a properly-prepared installation surface to fully collapse without any voids or air pockets.

Flat back-troweling tiles can fill in the inherent warpage of tiles; however, one must pay attention to the dry-set mortar/thin-set mortar manufacturer’s maximum thickness allowed for the bonding material that is being used. By filling the inherent warpage of a tile, the back plane of the tile is flatter and can be compressed uniformly into the properly-prepared notched ridges of the installation surface allowing ridges in the dry-set mortar/thin-set mortar to fully collapse without voids or air pockets, providing the mortar coverage and support required per ANSI A108.5.2.3.4.

Flat back-troweling is also recommended when installing stone or large-format tiles.

## NOTCHED BACK-TROWELING

Notched back-troweling is required for the installation of GPTP (Gauged Porcelain Tile Panels) per ANSI A108.19.13.6. Because the motion to slide a tile to collapse the ridges is virtually impossible with GPTP, notched back-troweling is the technique used

### Flat Back-troweling & Notched Back-troweling

to fill the ridges between the substrate and the tile when it is installed. ANSI A108.19.15.0 contains the required mortar coverage requirements specific to GPTP.

There are a few instances in installation procedures, such as installing tile on a ceiling, installing irregular or cleft stone tile or installing handmade tiles that are naturally warped, where it may be advantageous to key the mortar into the substrate and use notch back-troweling to apply mortar to the back of the tile before placing the tile on the substrate and embedding the tile. As always, the notches must be in one direction, aligned (parallel) with the substrate notches creating a zipper effect and fully collapsed to achieve the necessary mortar coverage and support.

CAUTIONARY NOTE: Any time notched back-troweling is used, the embedded thickness of the mortar cannot exceed the dry-set/thin-set mortar manufacturer's requirements or that of ANSI and or ISO. As always, selecting the correct size of notch trowel for mortar application is a key requirement for any properly installed installation.

## SUMMARY

Flat back-troweling and notched back-troweling are not required for most installations, refer to TTMAC current published methods as to when either one of these techniques is recommended or required.

Certain references in industry specifications and manufacturers' literature may leave the specifier and installer unsure about the necessity or requirement for flat back-troweling and notched back-troweling. If the thin bond coat on the back of the tile that is considered flat back-troweling is not embedded thoroughly enough to contact and collapse the notched ridges of a properly-prepared installation surface, it serves no purpose except to increase the cost of the installation through extra material and labor costs.

As with all installations, the bond coat coverage required depends on the type of installation. Per TTMAC 09 30 00 3.3.5 interior or non-wet area installations require 80% coverage, while TTMAC 09 30 00 Notes to the Professional, Execution state that exterior, wet area and stone installations require 95% coverage. Flat back-troweling a tile cannot take the place of the coverage requirement. It may look like you have 100% coverage when you flat back-trowel a tile, however, coverage also requires for the tile to be fully supported as specified under A108.5.2.3.4. Notched back-troweling can help with the coverage requirement and support of a tile, but once again a properly prepared installation surface with the proper sized notch trowel will ensure the coverage and full support as required by the TTMAC.

It is the position of the TTMAC is that installing tile using the one directional troweling method and collapsing the ridges through a sliding motion perpendicular to the troweled ridges is the best method for properly installing tile. There are specific uses for flat back-troweling and notched back-troweling. If these specific uses are not done properly, there is little to no benefit to the tile installation, only causing increases in time and cost.

## OPTICAL HAZING POSSIBLY CAUSED BY POST-FIRE ORGANIC COATINGS AND/OR POLISHING INCONSISTENCIES

On occasion, inconsistencies in the reflective properties of polished tile surfaces have been observed. Sometimes called optical hazing, this distortion can be invisible under normal lighting and only noticeable when illuminated by light coming in from the side at a low angle. A variety of inconsistencies have been reported, including light-colored cloudy spots, dark shadow spots, dark shadow ribbons that run across the entire tile, wavy regions of inconsistent reflectivity, and fuzzy spots or distorted lines in a reflected image. Unfortunately, these conditions are discovered most often after tile has been installed and in service. They are commonly thought to be as a result of grout haze or traffic stains.

There are at least two broad possible causes of optical hazing:

1) the presence and/or partial removal of certain post-fire organic coatings, and 2) inconsistencies in the materials being polished or in the polishing process itself.

With regards to post-fire organic coatings, there are different types which serve different purposes. Most are of a wax-like consistency, and several are described as “nano-coatings” (which may or may not contain nano-sized particles). Some coatings are intended solely to protect polished products from scratches during handling and installation, some are intended to increase luster, some are intended to improve stain resistance of products which weren't fully vitrified prior to polishing or which, while vitrified, have open micro-pores from the polishing process, and some are intended for a combination of the above. If optical hazing is observed and post-fire organic coatings are contributing to the problem, the coating may be uneven and refracting light waves in a non-uniform manner, the coating may have been scratched, buffed, or partially removed due to the installation process or normal wear, or foreign material may have been encapsulated in the coating. There are no standards for the nomenclature,

performance or handling of post-fire organic coatings. Although some tile distributors caution purchasers with notice of coatings, most distributors are unaware that they were applied; if it is intended to be removed; how it can be removed; and recommended installation and maintenance for coatings which are intended to be permanent.

including polishing technology (e.g. static head vs. sliding head), polishing compounds, maintenance of the polishing machines, and the characteristics of the material being polished.

While post-fire organic coatings and polishing are two separate issues, both may be relevant to optical hazing. As is the case in many other situations involving product aesthetics and consumer expectations, there are no standards for luster or the final reflectivity of polished products. Experience with manufacturers' products is a useful guide whenever there are no standards on which to rely.

Purchasers are strongly encouraged to speak with the manufacturers and distributors of the products they are considering and carefully examine polished products for overall quality, consistency, and the presence of post-fire organic coatings. Purchasers are also encouraged to consult with their suppliers where polishing quality is unacceptable or when post-fire organic coatings are present regarding their maintenance or removal if appropriate.

With regards to polishing inconsistencies, many factories have developed proprietary procedures to produce uniformly consistent high quality polished surfaces using sliding head polishing machines. Such machines incorporate a transverse oscillating motion to increase overall uniformity. The overall quality of a polished product is dependent on several factors,

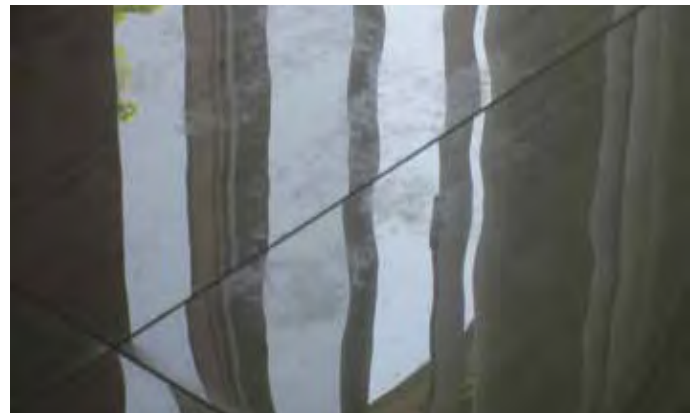

# GROUT GUIDE

These guidelines cannot address every installation. The type and size of tile, service level, climatic conditions, tile spacing, and individual manufacturer's recommendations are all factors that should be considered when selecting the proper grout.

| Reprinted with permission from the Tile Council of America and the Materials & Methods Standards Association (rev. 1996)<br>W = wall use<br>F = floor use | Grouts Containing Portland Cement                                   |                              |                                  |   |                             | Others                   |               |                      |              |
|---|---|------------------------------|----------------------------------|---|-----------------------------|--------------------------|---------------|----------------------|--------------|
|   | Commercial (Sanded) A 118.6   | Jobsite Mix (Sanded) A 118.6 | Dry-Set (Unsanded) A 118.6 H-2,3 | Commercial or Dry-Set with Latex (Polymer) A 118.7 H2,4 | Mod. Epoxy Emulsion A 118.8 | 100% Solid Epoxy A 118.3 | Furan A 118.5 | Silicone or Urethane | Mastic Grout |
|   | (4)   |                              | (4)                              | (4,9)   | (4)                         | (1, 3, 4, 6)             | (1,3,4,6)     | (2,4)                | (3,4)        |
| TILE TYPE   |   |                              |                                  |   |                             |                          |               |                      |              |
| Glazed Wall Tile (7)  | W   |                              | W                                | W   |                             | W                        |               | W                    | W            |
| Glazed Floor Tile (7)   | W,F   | W,F                          | W,F                              | W,F   | W,F                         | W,F                      |               |                      | W,F          |
| Ceramic Mosaics   | W,F   | W,F                          | W,F                              | W,F   | W,F                         | W,F                      |               | W                    | W,F          |
| Quarry, Paver, & Packing House Tile (8)   | W,F   | W,F                          |                                  | W,F   | W,F                         | W,F                      | W,F           |                      |              |
| Large Unit Porcelain or Vitreous Tile (8)   | W,F   | W,F                          | W,F                              | W,F   | W,F                         | W,F                      | F             | W                    | W,F          |
| Dimension Stone (7,8) (Including Agglomerates)  | W,F   | W,F                          | W,F                              | W,F   | W,F                         |                          |               |                      |              |
| USE   |   |                              |                                  |   |                             |                          |               |                      |              |
| Dry/Ltd. Water Exposure   | W,F   | W,F                          | W,F                              | W,F   | W,F                         | W,F                      |               |                      |              |
| Wet Areas (10)  | W,F   | W,F                          | W,F                              | W,F   | W,F                         | W,F                      |               |                      |              |
| Exteriors (8, 9, 10)  | W,F   | W,F                          | W,F                              | W,F   | W,F                         | W,F (4)                  | W,F (4)       | W,F                  |              |
| PERFORMANCE   | Note: There are 5 performance ratings, from Best (A) to minimal (E) |                              |                                  |   |                             |                          |               |                      |              |
| Suggested Joint Widths (5)  | 3 mm - 16 mm  | 3 mm - 16 mm                 | 2 mm - 3 mm                      | 2 mm - 16 mm  | 2 mm - 16 mm                | 2 mm - 16 mm             | 10mm - 16 mm  | 2 mm - 6 mm          | 2 mm - 6 mm  |
| Stain Resistance  | D   | E                            | D                                | C   | C                           | A                        | A             | A                    | B            |
| Crack Resistance  | D   | E                            | D                                | C   | C                           | B                        | C             | A                    | C            |
| Colour Availability   | D   | D                            | B                                | B   | B                           | B                        | Black only    | B                    | B            |

## NOTES:

1. Mainly used for chemical resistant properties.
2. Special tools needed for proper application. Silicone, urethane, and modified polyvinylchloride used in pre-grouted ceramic tile sheets. Silicone grout should not be used on kitchen countertops or other food preparation surfaces unless it meets the requirements of FDA Regulation No. 21, CFE 177.2600.
3. Special cleaning procedures and materials recommended.
4. Follow manufacturer's directions.
5. Joint widths are only guidelines. Individual grout manufacturer's products may vary. Consult manufacturer's instructions.
6. Epoxies are recommended for prolonged temperatures up to 60°C, high-temperature-resistant epoxies and furans up to 177°C.
7. Some types of glazed ceramic tiles, polished marble, marble agglomerates, and granite can be permanently scratched or damaged when grouted with sanded grout formulas. DO NOT use sanded grout or add sand to grout when grouting polished marble, marbled agglomerates, and ceramic wall tiles with soft glazes. Check the tile or marble manufacturer's literature and test grout on a separate sample area prior to grouting.
8. Some types of ceramic tiles and dimension stone may be permanently stained when grouted with pigmented grout of a contrasting colour. WHITE GROUT IS BEST SUITED FOR GROUTING WHITE OR LIGHT-COLOURED MARBLE OR GRANITE.
9. Latex modification may be required in areas subject to freezing temperatures. Consult grout manufacturer for recommended products and methods.
10. Coloured cementitious grouts may darken when wet.

## TROWEL RECOMMENDATIONS

**152 mm x 152 mm TO  
229 mm x 229 mm ON  
MASONRY OR  
CONCRETE WALLS**

**6 mm x 6 mm x 10 mm**

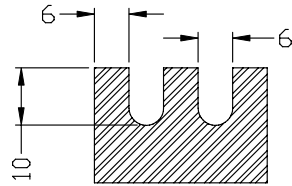

**305 mm x 305 mm  
AND LARGER ON  
MASONRY, CONCRETE  
OR DRY WALL**

**6 mm x 6 mm x 13 mm**

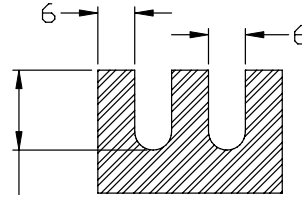

**305 mm x 305 mm AND LARGER CONCRETE, ON MASONRY OR  
TILES WITH THICKNESS VARIATION**

**10 mm x 19 mm x 14 mm**

**10 mm x 19 mm x 15 mm**

**13 mm x 13 mm x 13 mm**

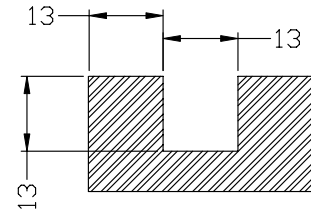
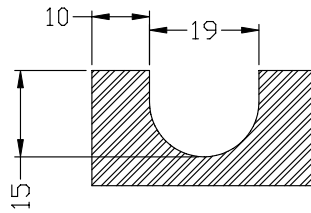
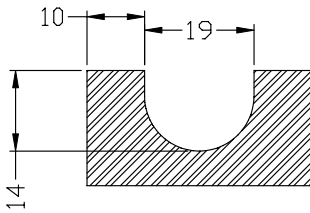

**108 mm WALL TILE AND CERAMIC MOSAICS ON DRY WALL**

**5 mm x 4 mm**

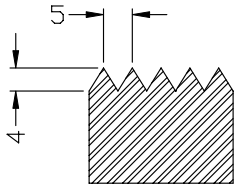

**152 mm x 152 mm TO 229 mm x 229 mm ON DRY WALL**

**6 mm x 6 mm x 6 mm**

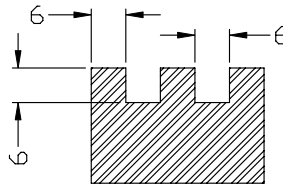

**108 mm WALL TILE AND CERAMIC MOSAICS ON MASONRY AND CONCRETE**

**6 mm x 6 mm x 8 mm**

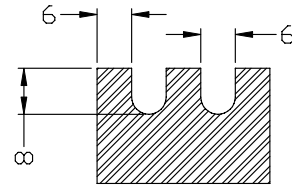

**152 mm x 152 mm TO 229 mm x 229 mm ON MASONRY OR CONCRETE WALLS**

**6 mm x 6 mm x 10 mm**

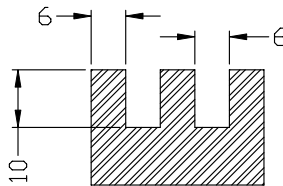

**EURO NOTCH TROWEL**

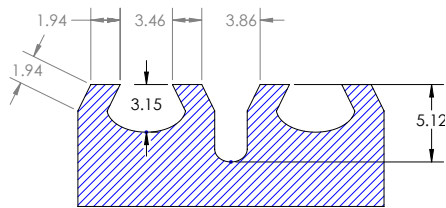

**8 mm x 8 mm 45° ANGLED NOTCH TROWEL**

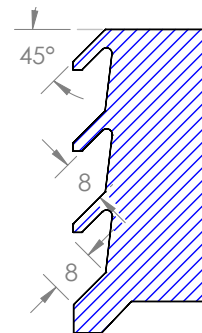

**NOTE:** Guidelines do not address every installation setting practice. The substrate, type & size of tile intended, service level of the installation and individual manufacturer's recommendations all affect the approximate coverage of the given setting material.

**UNSUITABLE SUBSTRATES FOR THIN-SET METHODS** - some plywood, particleboard, waferboard and strandboard. Compatibility of substrate for thin-set material must be confirmed by the manufacturer.

## GROUTING MATERIALS

Notes for the specifier:

- Pigmented grouts may cause staining of some ceramic tile or natural stone, precast terrazzo tile, textured tile and other porous materials. Staining can be minimized by selecting grout colours close to the tile colour or by applying a topical (removable) coating to the face of the tile prior to grouting. It is recommended that all unglazed tile be tested with the grout that will be used prior to installation to determine whether staining will be a problem. For further information refer to the latest TTMAC Maintenance Guide.
- Sanded grouts may scratch some natural stone and agglomerates or soft glazes on ceramic tile.
- Test prior to use.
- Generally, epoxy grout is not recommended for exterior installations. Consult with manufacturer to ensure suitability of their products. Epoxy grouts should be tested prior to use to ensure that they do not stain the products being installed. When grouting thick tile with narrow joints, take special precaution to ensure joints are completely filled with grout. It is recommended that all tile be tested with the grout that will be used prior to installation to determine whether staining will be a problem.
- Grout joint width for floors and walls are normally 2 mm to 6 mm depending on the type of material. Required grout joint width (joint width is the space between vertical edges of tile) should be specified (butt joints are not acceptable). Tile with bevelled or cushioned edges will appear to have wider grout joints than specified. For ease of maintenance, grout joints should be flush with face of the tile. Grout depth maximum tolerance must not exceed the depth of the bevelled or cushion edge of the tile. For rectified tiles, grout must be flush with the surface of the tile for joint widths up to 6 mm; maximum allowable grout concave depression not to exceed 1 mm for joints in excess of 6 mm up to 10 mm. Concave depression in the middle of the joints in excess of 10 mm width not to exceed 2 mm. For epoxy grouts, joints must be filled flush with tile edges to a maximum concave depression in the middle of the joint not exceeding 1 mm for joints up to 6 mm and 2 mm for wider joints up to 10 mm. Manufacturer's recommendations must be followed. A minimum of 2/3 of joint depth should be kept open for grouting and grout must penetrate the joint to the bond coat.
- For rough textured or irregular surface tile it is advisable to preseal or prewax tile prior to grouting.

COMMERCIAL PORTLAND CEMENT GROUT (ANSI A118.6) - A mixture of Portland cement, silica sand and pigments normally supplied as a bagged, pre-blended mixture which cures to a dense, water resistant material. Damp curing is normally required.

STANDARD CEMENT GROUT (ANSI A118.6) - A grout designed for use with wall tile consisting of a blend of Portland cement, calcium carbonate or other fine filler and a water retention agent. This grout can be used without pre-soaking absorptive wall tile. Damp curing may help develop greater strength and water resistance.

LATEX-PORTLAND CEMENT GROUT (ANSI A118.7) - A grout of the same composition as the two preceding grouts but mixed with a latex additive. May be supplied with a dry, redispersible latex additive in the packaged premixed grout in which case the product may be referred to as a polymer modified grout. Latex additives reduce the water absorption of grouts, improve stain resistance and increase the bond strength to ceramic tile. Normally dry cured for 24 hours. Damp curing may be required under some conditions.

EPOXY GROUT (ANSI A118.3) - A grout similar in composition to epoxy mortar but normally supplied in a variety of colours and formulated to permit clean up with water. Chemical resistance and temperature resistance of products should be determined by reference to manufacturer's literature. With tile thicker than 13 mm it may be very difficult to completely fill joints less than 6 mm wide.

FURAN RESIN GROUT (ANSI A118.5) - A grout similar in composition to furan resin mortar used where required for chemical resistance. Normally only supplied in black colour. Use of this grout requires special installation skills including the waxing of tile prior to setting and steam cleaning after grout has cured.

ORGANIC PREMIXED GROUT (ANSI 118.19) - A ready for use factory prepared mixture of water, polymers, aggregates, pigments and other materials to produce a water resistant, stain resistant, and uniformly colored materials use as joint filling for ceramic tiles and natural stones. The joints widths are within 1/16"-1/2".

NOTE: Guidelines do not address every installation setting practice. The substrate, type and size of tile intended, service level of the installation and individual manufacturer's recommendations all affect the approximate coverage of the given setting material.

## QUESTIONABLE/UNSUITABLE SUBSTRATES

### UNSUITABLE SUBSTRATES

Unsuitable substrates are substrate types that are not suitable to receive direct bond applications of ceramic tile and stone under any circumstances. The following are examples of unsuitable substrate types:

- Masonite
- All grades of lauan plywood
- Any untreated polystyrene insulation boards without tileable surface coatings
- Extruded polystyrene insulation board
- Particle board
- Paneling
- Stripwood floors
- Hardwood floors
- Grease saturated concrete
- Contaminated concrete
- Cushion backed vinyl flooring
- Paper and glass mat exterior gypsum sheathing
- Pressure treated plywood
- Fire-resistant plywood
- Chemically treated plywood
- Felt paper
- Cutback or other adhesives
- Paint
- Metal (including steel)
- Plastic laminates
- Epoxy coatings
- Seamless flooring
- Non-cushioned vinyl flooring
- Vinyl tile
- Chemically treated concrete
- Chemically hardened concrete
- Pre-cast concrete

### QUESTIONABLE SUBSTRATES

Questionable substrates are substrate types that when properly designed and prepared can receive direct bond applications of ceramic tile and stone. Some questionable substrates conform to specific ceramic tile and stone industry installation methodology when applicable requirements are followed. In addition, the use of specific installation materials designed for unique applications can result in a successful installation. Consult ceramic tile and stone installation manufacturers for their recommendations. The following are examples of questionable substrate types:

- Scribing felt
- Substrates that exceeds recommended deflection under design loads
- Curing compound treated concrete\*
- Form release treated concrete or masonry surfaces\*
- Structural Plank (shiplap)
- Post-tensioned concrete
- Grease-coated concrete
- Light-weight concrete
- Cork
- CDX plywood
- Gypsum concrete
- Gypsum plaster
- Poured gypsum underlayment
- Access panels
- Cracked concrete
- Wire-lath-scratch coat\*

\* Mechanical abrasion (e.g. shot blasting, high pressure water blast, sand blasting, etc... is required to bring these substrate types into conformance with industry standards).

\* Certain unsuitable substrate types can receive ceramic tile and stone installations when installed with a non-bonded thick bed mortar floor assembly or a cleavage membrane/lath and plaster wall assembly or when installing with specialized adhesive with proper surface preparation.. Consult tile and stone installation manufacturers for their recommendations.

## PROFILES

Profiles are strips of metal or plastic incorporated into a tile installation. Floor profiles finish and protect tile edges where tiles transition to other floor coverings, such as hardwood, carpet, and vinyl. Sloped floor profiles additionally transition changes in height. Wall profiles can be used at outside corners, or as a cap on tile base or wainscoting in lieu of trim units. Movement joint profiles are an alternative to traditional sealant-filled joints. Cove profiles are used at inside corners as a transition between two walls or between floor and wall tile.

Profiles are available in various materials, finishes, colors, and heights. Select the correct material considering traffic and environmental conditions (chemical exposure, etc.) and the correct height considering the tile thickness and setting bed thickness.

There are no standards currently set for these products. As with any product for which there are no standards, consult manufacturer for all performance and installation criteria.

## MEMBRANES AND UNDERLAYMENTS

### Cementitious Backer Units (ANSI A118.9)

These types of boards are for use on floors, walls and ceilings in both dry or wet areas. It is applied directly to wood or metal studs and as such is considered a solid backing. It can be used on wood floors but only in 11 mm thickness or more. When used in wet areas on walls a polyethylene sheet must be used behind or waterproofing should be applied on the surface of the board.

### Waterproof Membranes (ANSI A118.10)

These membranes may be trowel applied, built up membranes, liquid applied, or sheet applied materials. Some materials are suitable only for use under mortar bed installations while others may be used in either mortar bed or thin-set methods. Some products are designed to be used as both a waterproofing membrane and as a bond coat for setting ceramic tile. In all cases, refer to the manufacturer's recommendations and local building by-laws and codes regarding limitations and suitable applications. Most waterproofing membranes are not suitable for use where hydrostatic pressure from below is present. Not all waterproofing membranes are vapour retarders and as such are not suitable for steam rooms. Some membranes are resistant to high PH conditions. Contact manufacturer for suitability. There is an ISO Standard for Liquid Applied Waterproofing Membrane ISO 13007-5.

### Crack Isolation Membranes (ANSI A118.12)

Crack isolation membranes for thin-set ceramic tile and dimension stone installations isolate the tile or stone from minor in-plane substrate cracking. Membranes covered by this specification are bonded to a variety of manufacturer-approved substrates covered by ANSI specifications. In some cases the trowel-applied products can be used as the adhesive for the ceramic tile or dimension stone as well. Other products within the scope of this specification are allowed to cure or are applied as sheet goods and are then used as the substrate for the application of ceramic tiles and dimension stone by traditional methods and materials. This standard applies to trowel applied, liquid, and sheet membranes. Testing requirements are as follows: Fungus and Microorganism Resistance; Shear Bonds; Point Load Testing; Robinson Floor Test; and System Crack Resistance Test. Performance ratings are: Standard Performance: Tile failure occurs after 2 mm specimen gap opening, but before 3 mm gap opening. High Performance: Tile failure does not occur by 3 mm specimen gap opening.

These membranes provide the lowest profile (elevation) of the tile installation incorporating a crack isolation membrane. Consult individual manufacturers for specific instructions, application, performance levels, and limitations concerning their materials. Follow the individual manufacturer's written instructions precisely. This standard was developed to provide specifiers and installers with the minimum criteria necessary for a material to function as a deterrent to crack propagation from the substrate through the finished thin-set tile or stone installation.

The installation specification for Crack Isolation Membranes is ANSI A108.17. It is highly recommended that any or all crack isolation systems be evaluated by the split slab Tile Assembly Floor Tester (See Selection Table page 35).

NOTE: The TTMAC does not endorse any one material used as a crack isolation membrane. Consult the manufacturer to determine whether their product will withstand the anticipated movement and loads involved. A crack isolation membrane will not prevent cracking of ceramic tile if there is vertical movement of adjacent surfaces. The terms anti-fracture or crack suppression membranes are not appropriate designations for this type of product.

### Bonded Sound Reduction Membranes (ANSI A118.13)

Bonded Sound Reduction membranes lower the transmission of sound from one room to the room below. This test method was specifically designed to be used below ceramic tile. This test method can be used for stone but with caution as stone tile are relatively fragile and susceptible to cracking and chipping which can be even more predominating when stone is placed over sound reduction materials, which are almost always resilient or compressible by nature. This standard applies to trowel applied, liquid and flexible sheet membranes being such these membranes provide the lowest profile (elevation) for the tile installation incorporating a bonded sound reduction membrane. Testing requirements are as follows: Fungus and Microorganism Resistance; Shear Bonds, Robinson floor test (ASTMC 627) and sound testing ASTM E2179. ASTM C627 "Robinson Floor Test" min. Residential Rating. Sound performance requirements are the floor assembly shall obtain a  $\Delta$  IIC rating of 10 or greater.

**Flowable Hydraulic Cement Underlayment/Self-leveling Underlayment (ANSI A118.16)**

Are intended for use in flattening horizontal substrates of minor irregularities in preparation for installation of all types of tile and stone. May be used to level a substrate but these mortars are typically formulated to be applied in thicknesses from featheredge up to 38 mm.

**Foam Core Backer Board (ANSI A118.18)**

A nailable/screwable backer board or underlayment panel which is composed of a rigid foam core and may be covered and/or reinforced with facers or coatings. They are designed to receive a tiled or similar suitable surface finish material. Foam core backer boards have a significant ability to remain unaffected by prolonged exposure to moisture and prevent the passage of water. They may be used in dry or wet areas for interior floors, walls, and ceilings. Consult with foam core backer board manufacturer for specific use and limitations.

**Vapor Retarder Membranes**

There are no materials that can completely stop the transmission of water vapor except solid metal or glass. Vapor retarders however can be an effective means to control water vapor especially in steam room and steam showers. Vapor permeance is tested under ASTM E-96 and recently it was identified that for steam rooms and steam showers this testing requires should be under ASTM E-96 -E with 90 % humidity and 37.8 C. Typically, most building codes require a minimum of less than 1.0 perm but as of 2012 for continuous use steamrooms such as in a fitness center or health spa the requirement recommended is .5 or less. Most membranes that meet ANSI A 118.10 for waterproof membranes do not necessarily perform as a vapor retarder. Please verify with manufacturer if their product qualifies as a vapor retarder.

**Uncoupling Membranes ANSI A118.20 (to be ratified early 2025)**

These membranes are geometrically configured to create free space between the tile and the substrate which allows a combination of functions to allow tile installations over problematic substrates. These functions include independent movement between the substrate and tile, vapour management, waterproofing, supporting and load distribution. Mortar recommendations will vary from one manufacturer to another and manufacturer’s recommendations must be followed and take precedence over industry norms. There is currently no standard for uncoupling membranes in either ANSI or ISO, however one is under development by the MMSA (Materials, Methods and Standards Association). The MMSA have established one performance criterion that the membrane must be able to achieve 50 PSI or greater shear bond strength after a 7 day cure per the test method in ANSI A118.12 Section 5.1.3. Consult the manufacturer’s written literature for specific application details. ANSI has designated Uncoupling membranes under ANSI A118.20 and it will be completed later this year and it will be revised on the TTMAC web-site when finalized

**Electrical Heating Membranes/Matting**

Electrical heating membranes are designed with a means to embed a heating wire and sensors beneath the tile layer to provide under-floor heat. Often, they also provide benefits such as uncoupling, sound control, and/or waterproofing so they can take the place of other membranes in this guide. Use of these membranes requires consideration of how the wire will be routed prior to installation. Utilizing these membranes necessitates careful consideration of factors like layout, required current, circuit tests, and manufacturer’s guidelines prior to installation. The tile installation cannot be done when the heat is in use and may require a minimum of 7 days after the tile installation before the heating system can be turned on. Preheating and testing of the heating system needs to be conducted prior to the installation of the Tile. After installation, care must be taken not to break or damage the wire. Traditional means of removing excess mortar from grout joints can damage wires. The installation of hardware to mount glass or partitions can damage wires. Consult the manufacturer’s written literature for specific application details.

**SPEC NOTE:** Select appropriate ANSI Materials Method for Installation Method.

| MATERIALS ANSI   | INSTALLATION ANSI |
|--|-------------------|
| ANSI A 118.9 Cementitious Backer Units                             | ANSI A108.11      |
| ANSI A 118.10 Load Bearing Bonded Waterproof Membranes             | ANSI A108.13      |
| ANSI A118.12 Crack Isolation Membrane                              | ANSI A108.17      |
| ANSI A118.16 Flowable Hydraulic Cement/Self Levelling Underlayment | ANSI A108.21      |
| ANSI A 118.18 Foam Core Backerboards                               | ANSI A108.18      |
| ANSI A118.20 Uncoupling Membranes (coming 2025)                    | TBA               |

| Tile Testing Comparison/Equivalents Between ISO and ASTM |               |  |                                |                |  |
|--|---------------|--|--------------------------------|----------------|--|
| TYPE OF EXAMINATION                                      | ISO STANDARDS | VALUE/ RESULT  | TYPE OF EXAMINATION            | ASTM STANDARDS | VALUE/ RESULT  |
| THICKNESS  | ISO 10545-2   | ± 5%   | THICKNESS                      | ASTM C-499     | Range of thickness < 0.04"   |
| EDGE STRAIGHTNESS  | ISO 10545-2   | ± 0.5%   | EDGE STRAIGHTNESS              | ASTM C-509     | Wedging ± 0.25%  |
| WARPAGE  | ISO 10545-2   | ± 0.5%   | WARPAGE                        | ASTM C-485     | Warpage ± 0.4%   |
| LENGTH AND WIDTH   | ISO 10545-2   | ± 0.5%   | LENGTH AND WIDTH               | ASTM C-499     | ± 0.25%  |
| WATER ABSORPTION   | ISO 10545-3   | ± 0.6%   | WATER ABSORPTION               | ASTM C-373     | Impervious ≤ 0.5%  |
| FLEXURAL STRENGTH  | ISO 10545-4   | ≥ 0.5%   |                                |                |  |
| BREAKING STRENGTH  | ISO 10545-4   | ≥ 35N/mm <sup>2</sup>  | BREAKING STRENGTH              | ASTM C-648     | ≥ 113 kg   |
| SHOCK RESISTANT  | ISO 10545-5   | RESISTANT  | SHOCK RESISTANT                | -              | -  |
| DEEP ABRASION  | ISO 10545-6   | 175 mm <sup>3</sup> MAX  | DEEP ABRASION                  | ASTM C-1243    | V=mm <sup>3</sup>  |
| RESISTANCE TO THERMAL SHOCK                              | ISO 10545-9   | RESISTANCE RQUIRED AT 10 CYCLES                                  | RESISTANCE TO THERMAL SHOCK    | ASTM C-484     | no sample must show alterations to surface   |
| FROST RESISTANCE   | ISO 10545-12  | RESISTANT/ NOT RESISTANT   | FROST RESISTANCE               | ASTM C-1026    | no sample must show alterations to surface   |
| RESISTANCE TO CHEMICAL ETCHING                           | ISO 10545-13  | NO SAMPLE MUST SHOW VISIBLE SIGNS OF CHEMICAL ATTACK             | RESISTANCE TO CHEMICAL ETCHING | ASTM C-650     | no sample must show alterations to surface   |
| RESISTANCE TO STAINING                                   | ISO 10545-14  | CLASS 2 TO 5 (5 HIGHEST - STAINS REMOVED WITH HOT RUNNING WATER) | RESISTANCE TO STAINING         | CTI 81-7D      | no evident variation   |
| SLIP LEVEL   | DIN 51130     | R9 TO R13 (HIGHEST RESISTANCE)                                   | SLIP LEVEL                     | ANSI A326.3    | Wet ≥ 0.42 Dry ≥ 0.42<br>Higher classifications for more demanding environments and manufacture declared performance should be taken into consideration. |
|  | DIN 51097     | CLASSES A, B & C (C HIGHEST BAREFOOT SLIP RESISTANCE)            |                                |                |  |

## \*SOUND CONTROL UNDERLAYMENTS

A revised version will be available in 2025 so please check on the TTMAC website  
<https://www.ttmac.com/en/technical/specification-addendums>

There are 2 types of ratings used for sound control: STC (Sound Transmission Class), which is airborne sound, such as speaking, music, etc. and IIC (Impact Insulation Class), which is sound from people walking, moving chairs, dropping objects, etc. Presenting the greatest challenge for the STC component of sound control is high-frequency sound energy, such as that which is produced by a blow-horn or a whistle. The greatest challenge for sound control in regard to IIC is low-frequency sound energy, such as that which occurs when a basketball is dropped on the floor.

### STC Ratings

The term STC refers to the single figure of evaluation used to quantify the transmission of airborne sound through building elements, such as walls or floor systems. These types of sounds would be the equivalent of voices, radio, or television in the context of a multi-family building. The term STC translates to Sound Transmission Class and is measured and stated in accordance with ASTM Standard number C634 and tested via the test methodology of ASTM Test Methods E90, E336, and E596. When done in an accredited test laboratory, these values are stated as an exact number to the right of the initials STC. When done in the field, using ASTM Method E336, the values are designated by the initials FSTC to the left of the numeric value. STC values are in a large part influenced by the solid mass of the structure, but are also dependent on isolation and resilience within the structure.

### IIC Ratings

The term IIC refers to the statistical measurement standards used to quantify the transmission of impact sound energy through a floor/ceiling assembly system. These types of sounds would be the equivalent of foot traffic, dropped articles, or furniture moving in the context of a multi-family building. The term IIC translates to Impact Isolation Class and is measured and stated in accordance with ASTM Standard numbers C634 and E989 and tested via the test methodology of ASTM Test Method E492 and E2179. When done in an accredited test laboratory, these values are stated as an exact number to the right of the initials IIC. When done in the field, using ASTM Method E1007, the values are designated by the initials FIIC to the left of the numeric value. IIC values are not heavily influenced by the presence of solid mass in the structure. IIC values are usually dependent on the presence of a resilient material somewhere in the assembly to isolate and absorb the sonic energy created by impacts.

### AIIC Single Index

This is a new metric introduced in 2011 and is equivalent to interpreting the FIIC when it is deemed «apparent». In other words, the AIIC metric (as it is described in the ASTM E1007-16 standard) formally represents soundproofing of the partition wall as well as all the other partition walls in the receiving room. This means that the AIIC metric not only represents soundproofing of the partition wall but soundproofing between two adjoining rooms. Just as with the FIIC metric, it is weighted according to sound absorption of the room and is only meaningful when a) the receiving room has a low level of absorption and b) the space is geometrically simple, homogenous, closed and neither too small nor too big. The same restrictions and mathematical derivations apply here as with the FIIC metric. For these reasons, ASTM introduced two more sound impact metrics in 2011, i.e. NISR and ISR, to complete the standard and provide a more meaningful scope for representing on site conditions.

### ISR Single Index

This is a new metric introduced in 2011 which measures noise impact as experienced by the inhabitants of the receiving room being tested, without correction according to reverberation time, level of absorption in the receiving room or without volume restrictions (large or small). This metric provides meaningful, true and reliable results as to actual experience, but does not allow comparison or objectification of performance between two rooms because results are a function of furnishings present.

For the usual comprehension (with no expertise in acoustics), these metrics appear to make this a complex process, but in fact, they provide a better framework for interpretation of results, and provide a better standard for measurements and protocols, thus giving a better picture of on site performance for acoustic expert.

### NISR Single Index

This is a new metric introduced in 2011 which measures weighted sound impact according to a 0.5 second standard reverberation time. This standard reverberation time represents typical echo encountered in apartment buildings, which are furnished and/or inhabited (as defined by the CRNC). Used in this way, this metric offers a meaningful soundproofing measure whether the receiving room is empty, lightly or heavily furnished. This metric also offers meaningful results whether the room is of simple, complex or very irregular shape. The only restriction is that the receiving room must have a volume between approximately 20 m<sup>3</sup> and 150 m<sup>3</sup> to reflect reverberation time as it relates to the volume.

### STC and IIC Ratings and Building Codes

In multi-family construction, in Canada, there are minimum IIC and STC values that the floor/ceiling assembly must achieve to meet the National Building Code (NBC) standards. The NBC requires a minimum 50 STC rating and recommends but does not require a 50 IIC. The higher the IIC or STC, the better the sound attenuation, with 50 considered the minimum for multi-family dwellings. The NBC may not require a 50 IIC but it would be extremely advisable to meet a minimum of 50 IIC as impact sound is usually the most objectionable to people's privacy.

In addition to the building code standards, some condominium developers and condo homeowners associations have their own minimum standards written into their condo bylaws, which are often more stringent than the NBC. It is wise to consult your condo association in regard to their by-laws and standards for the required IIC and STC values before installing hard surface flooring materials in your unit or project.

### Challenges

A number of different materials are promoted and used for sound control in floors. Each material is only one component of a complete system in which each component is an essential part of the total assembly. Elimination of any component of the assembly can seriously deplete the sound rating desired. Most of the data available to the market relates to tests of floor/ceiling systems that are comprised of concrete slabs with gypsum wallboard hung on resilient furring channels (suspended or sound-rated ceiling system) with a layer of mineral wool or fiberglass insulation in the cavity. Unfortunately, most of the construction detail in the field does not have this type of ceiling treatment.

When done in an accredited test laboratory when conducted as per ASTM E2179, these values are stated as an exact number to the right of the initials IIC and actually give a separate IIC contribution value number of the product assembly by itself indicated by the Delta symbol  $\Delta$ . This number provides an excellent way to evaluate different products, and to determine if additional key components (e.g., a suspended or sound-rated ceiling assembly) are needed. Products that have only Field Test reports (FIC) and no laboratory testing should be considered with caution. Field tests are project specific; comparing different field tests done in different buildings is not an accurate way to make a proper assessment of product performance.

Many materials that are promoted for sound control in hard surface flooring may not be suitable for direct bond tile and stone installations, as they are too compressible and do not provide proper structural support for these installations. In many cases, it is necessary to use additional reinforcing materials, such as mortar beds, poured in place overlays, backer boards, epoxy mortars and grouts, thicker tiles, and other methods to provide a structurally sound installation.

It is recommended that all products/systems to be used for sound control be subjected to ASTM C627, commonly referred to as the Robinson Floor Test, and that such products/systems meet a minimum "Residential Rating." All components of the test assembly should be divulged to determine that the product in question is able to achieve the performance rating desired, for the given installation design and the same or similar materials should be used for the sound testing. In particular the size, thickness, and type of tile, mortar and grout should be consistent.

**ANSI A118.13** Standard for Bonded Sound Reduction Membranes for Thin-set Ceramic Tile and Dimension Stone.  
For details see page 29.

### Concrete Slab Subfloors

Concrete slabs come in a variety of thicknesses and compositions (e.g., hollow core, post-tensioned, prestressed). The most commonly cited are 150 mm and 200 mm concrete slabs with or without a suspended ceiling assembly. Test results for these two thicknesses vary when comparing field tests versus laboratory tests. The field tests result in a much higher range of values than those conducted in the labs.

If a suspended ceiling assembly is not possible, the most effective method to establish an improved IIC rating is to install a "floating" floor system. This can be done by utilizing a layer of some type of acoustically rated resilient material, followed by a layer of lightweight concrete, mortar bed, or gypsum concrete (typically 19 mm or more, depending on material), onto which the tile or stone is installed.

### Wood Joist Floors

For aesthetics and design purposes, wood frame construction will normally have a gypsum wallboard ceiling assembly. To achieve a solid base of sound control, the use of resilient metal channels supporting the gypsum wallboard and sound-absorbing insulating batts in the cavity is recommended. An assembly of this nature with a single layer subfloor has an approximate IIC rating of 45. Adhering a tile or stone surface will actually lower the IIC to around 40. The reason for this is that the hard surface increases noise levels at the higher frequencies, thereby reducing the overall IIC rating. If the sub-floor thickness is doubled and the ceiling wallboard panels are doubled as well, the net effect will increase the STC rating, as well as the IIC rating.

### Key Points to Remember

- It is not good practice to select materials or systems based solely on field tests. Lab tests are a more accurate model for predicting performance in a range of different construction types, field tests are accurate only for the site where the test was performed.
- If field tests are being conducted, require both before and after installation testing.
- Testing labs should be NVLAP certified and meet the criteria established in ASTM guidelines E548, E597 and in ASTM Standard E717.
- Sound abatement materials are often quite resilient, so a Robinson Floor Test (ASTM C627) is strongly recommended and is required by the new standard ANSI A 118.13. This test can be conducted by the TTMAC.
- The size, thickness and type of tile as well as the type of mortar and grout used in the Robinson Floor Test should be the same as that shown for the sound control rating desired.
- If a suspended sound rated ceiling is not being used, then a relatively thick assembly on top of the slab may be required (e.g. full mortar bed) to achieve a 50 IIC.
- See page 105 for Sound Control Systems on Interior Floors.

\*Portions of the preceding information reprinted with the permission of the MMSA and the TCNA.

## TESTING AND STANDARDS

Since the CAN/CGSB 75.1-M88 was withdrawn, the Terrazzo Tile and Marble Association has decided to adopt the ISO 10545 standards complimented by ASTM standards for missing topics. The ISO 10545 is written for ceramic tile only and not stone tile. The TTMAC Manual covers both so stone tile will be using the ASTM standards.

The test standards may be very useful for evaluating the performance of a particular type of tile, ceramic or stone. It is important to note the specific test number that has been used in order to confirm that results are comparable. The standardization of the testing methods is also critical to ensure comparability. It is important that all tests are performed professionally, by independent laboratories to ensure usable results. Home-made tests lack controls and accurate measuring and are therefore discouraged.

ISO Canada has been a “P” participating country with the International Standards Organization for over 16 years now under TC (Technical Committee) 189. The TTMAC put together a committee of experts which report directly to the Standards Council of Canada the liaison to ISO. As a participating member, the member country eventual goal is to adopt the ISO standard as its own standard, withdrawing the domestic equivalent. In the revision of this manual, the TTMAC Specifications Committee decided to identify the equivalent standards between ANSI and ISO so as to get the reader and the industry to get familiar to the ISO standards.

### ISO 13007 standard

Under ANSI standards, a product must meet a minimum material standard to be included in a category such as ANSI A 118.4. With ISO 13007 standards, the products meet the standard for “normal” and can optionally be tested further for “improved” performance for a variety of identified product characteristics. When used in combination with the ANSI standards, the ISO 13007 standards make it easier for specifying the right mortar and grout for the right application, benefiting both the architect and the installer.

The ISO 13007 standards are bringing simplicity and specificity to the architect’s task of specifying the most appropriate product for each tile or stone installation. The standards express product classifications alphanumerically, using simple letters and numbers. Letters describe the chemical nature of the adhesive (such as cement based, mastic, epoxy or urethane) along with special characteristics (such as fast-setting, slip-resistant or deformable). Numbers indicate whether the product performance is “normal” (such as normal bond strength, for light to medium traffic use) or “improved” (such as higher bond strength, for high traffic use).

|  | Adhesives                                |                            |  |  | Grouts                     |                            |  |
|--|--|----------------------------|--|--|----------------------------|----------------------------|--|
|  | TYPES                                    | CLASSES                    | SPECIAL CHARACTERISTICS  |  | TYPES                      | CLASSES                    | SPECIAL CHARACTERISTICS  |
|  | C = Cementitious (Thin-set mortars)      | 1 = Normal<br>2 = Improved | F = Fast-setting<br>T = Slip-resistant<br>E = Extended open time<br>S1 = Deformable<br>S2 = Highly deformable<br>P1 = Plywood adhesion<br>P2 = Improved plywood adhesion |  | CG = Cementitious grouts   | 1 = Normal<br>2 = Improved | F = Fast-setting<br>A = High abrasion resistance<br>W = Reduced water absorption |
|  | D = Dispersion (Mastics)                 | 1 = Normal<br>2 = Improved | A = Accelerated drying<br>T = Slip-resistant<br>E = Extended open time   |  | RG = Reaction resin grouts | -                          | Higher performance characteristics than improved cementitious grouts             |
|  | R = Reaction resin (Epoxyes & Urethanes) | 1 = Normal<br>2 = Improved | T = Slip-resistant   |  |                            |                            |  |

### ISO 10545 series tests

ISO 13006 is the International Standards Organization’s manual for ceramic tile excluding mosaics. The standard categorizes a tile by its forming method, either pressed or extruded, plus it’s water absorption. There is a further subcategory for extruded tiles as to whether they are natural or precision. The results are 12 categories, and each is assigned a chart which will define acceptable tolerances for the tile.

- |  |  |
|--|--|
| ISO 10545-1 Sampling                                 | ISO 10545-9 Thermal Shock                        |
| ISO 10545-2 Dimensions and Surface Quality           | ISO 10545-10 Moisture Expansion                  |
| ISO 10545-3 Water Absorption                         | ISO 10545-11 Crazeing (glazed)                   |
| ISO 10545-4 Modulus of Rupture and Breaking Strength | ISO 10545-12 Frost Resistance                    |
| ISO 10545-5 Impact Resistance                        | ISO 10545-13 Chemical resistance                 |
| ISO 10545-6 Resistance to Deep Abrasion              | ISO 10545-14 Stain Resistance                    |
| ISO 10545-7 Resistance to Surface Abrasion           | ISO 10545-15 Lead and Cadmium release from glaze |
| ISO 10545-8 Thermal Expansion                        | ISO 10545-16 Small Colour Differences            |

## ASTM C627

### ROBINSON FLOOR ASSEMBLY TEST

Various end use applications are listed in the following table together with recommended tile and installation methods. Results are based on ASTM C627 "Standard Method for Evaluating Ceramic Floor Tile Installation Systems", using the Universal Floor Tester (Robinson-Type Floor Tester). All systems are material dependent. Performance system ratings should not exceed the weakest component. Consult each material manufacturer to determine individual product suitable rating. Other construction may be used, based upon a history of successful use under similar conditions.

This table should be viewed as a general guide to durability under the listed service conditions, but the specifier should determine the suitability of products and installation methods for a particular application. Factors that should be considered include thickness of tile, breaking strength (ASTM C648), abrasion resistance, coefficient of friction/slip resistance, size and the degree of contact that will be achieved when setting the tile.

| PERFORMANCE REQUIREMENTS  | ASSEMBLY COMPONENTS & METHODS   |
|---|---|
| <b>EXTRA HEAVY</b><br>(Passes ASTM C627-99 cycles 1 through 14)<br>Extra Heavy and high impact use in shipping and receiving, food plants, dairies, breweries and commercial kitchens.                | Concrete substrate only.<br>Tile – 12+ mm quarry tile, 7 mm+ porcelain tile or packing house tile.<br>Installation 309F-2025, 310F-2025<br>Wood substrate - none  |
| <b>HEAVY</b><br>(Passes ASTM C627-99 cycles 1 through 12)<br>Latex modification recommended<br>Shopping malls, stores, airport terminals, work areas, laboratories, auto showrooms and service areas. | Concrete Substrate.<br>Tile–10 mm+ quarry tile, 7 mm+ porcelain tile, 13 mm+ terrazzo tile, 10 mm+ natural stone, 10 mm+ agglomerated, marble or granite.<br>Installation – 325ED-2025 (A,E)<br>Wood Substrate – 313F2025(A) (100% solids epoxy mortar) |
| <b>MODERATE</b><br>(Passes ASTM C627-99 cycles 1 through 10)<br>Normal commercial and light institutional use in public space of restaurants and hospitals (etc).                                     | Concrete Substrate<br>Tile – ceramic mosaic or heavier<br>Installation – 325 ED2025   |
| <b>LIGHT</b><br>(Passes ASTM C627-99 cycle 1 through 6)<br>Light commercial use in office space, reception areas, kitchens, bathrooms   | Concrete Substrate<br>Tile – ceramic, mosaic or heavier<br>Installation – 314F-2025, 325ED-2025 (A,E) and latex<br>Portland cement mortar bond coat over waterproof membrane.<br>Wood – 325ED-2025 (B,C,D)  |
| <b>RESIDENTIAL</b><br>(Passes ASTM C627-99 cycles 1 through 3)<br>Kitchens, bathrooms, foyers   | Concrete Substrate<br>Tile – ceramic, mosaic or heavier<br>Installation – 314F-2025, 325ED-2025 (A-E) and latex Portland Cement mortar bond coat over waterproof membrane<br>Wood – 325ED-2025 (A,B,C,D)  |

This is a progressive test. For example, any assembly passing the "extra heavy" application will automatically pass all other categories of lesser requirements such as heavy, moderate, light and residential.

### TTMAC UNIVERSAL FLOOR TESTER



The Universal Floor Tester is a unique machine. This machine is a redesign of the Robinson Type Floor Tester and is capable of carrying out the test for an ASTM C-627 designation. The ASTM test is designed to verify the suitability of a flooring system for a particular type of installation. The test method consists of preparing installation slabs that duplicate the type of installation under consideration, subjecting them to one or more tests, and evaluating the results in a prescribed manner. This test method provides a standardized procedure for evaluating performance of floor tile installations under conditions similar to actual specific usages.

A method to test long-span joists, underlayment, bonding material, tile, and grout was required. In order to test crack isolation membranes and the result of concrete cracking, it was necessary to design a split slab method. The Universal Type Floor Tester was designed to meet all of these requirements. This tester can slowly open and split the slab or it can be set for fast acceleration.

The new design allows for suspended floors to be assembled and tested at almost any given length and construction height up to 1,015 mm. Engineered wood assemblies with spans up to 4,573 mm or even longer can now be tested, and valuable data such as curvature of the span, deflection, twisting, and vibrations can all be monitored. Post-tension and pre-stressed slabs will be able to be tested fully suspended under the carriage of the tester.

The split slab mechanism capability of the tester is specific to this tester and is not known to be duplicated by any other testing apparatus currently available.

Revenue gained by our Association will allow us to increase expenditures on Research and Development and provide the ability to produce accurate specification guides.

### DCOF per ANSI A326.3

In ANSI A326.3, DCOF is defined as the ratio of the force necessary to keep a surface already in motion sliding over another surface divided by the weight (or normal force) of the sliding object. A326.3 notes, however, that DCOF shall not be the only factor in determining appropriateness of a product for a particular application. DCOF can provide a useful comparison of surfaces, but it does not predict the likelihood a person will or will not slip on a hard surface flooring material. While DCOF is the most widely used friction measurement metric in Canada & the US, it is only one piece of the puzzle when it comes to slip resistance!

Understanding the concept of slip resistance, coupled with proper interpretation of test data and standards, is relevant to real-world slip/fall potential. Consistency in product specification can lead to better product use, potentially causing a reduction in slip/fall incidents.

### ANSI A326.3 Revision

With the 2022 version of the standard, the concept of ‘manufacturer-declared’ classifications emerged. Manufacturers can declare their product classifications based on DCOF testing; other testing such as the German Ramp R values (referenced in many Canadian specifications) or English Pendulum; their experience with where the tiles are typically used without problem; and several other slip resistance-related factors.

Regardless of declared product use classification, ANSI A326.3 notes that specifiers shall determine materials appropriate for specific project conditions, considering by way of example, but not in limitation, type of use, traffic, expected contaminants, expected maintenance, expected wear, and manufacturers’ guidelines and recommendations

#### 5 New Product Use Classification Categories

1. Interior, Dry (ID) – These products shall have a dry DCOF of at least 0.42 (but will typically not list a wet DCOF) which includes most ceramic and glass floor tiles currently on the market. The standard gives some informative “possible areas of use” examples such as indoor malls not in the food court area, hotel lobbies, office buildings, showrooms, and houses in rooms other than bathrooms and kitchens.
2. Interior, Wet (IW) – These products shall have a measured wet DCOF of at least 0.42 or be manufacturer-declared for this classification based on manufacturing parameters, internal quality control criteria, and manufacturer experience with similar surfaces. Informative area of use examples listed in the standard include entry foyers, public restrooms without showers, grocery stores, ‘front of house’ applications in restaurants with separate kitchens, and home interiors including bathrooms and kitchens.
3. Interior, Wet Plus (IW+) – Products must be manufacturer-declared for this classification. In the absence of a superseding manufacturer-declared product use classification, a DCOF of 0.50 or greater is generally accepted for this category. Informative area of use examples listed in the standard include ‘front of house’ for fast casual and quick-service restaurants, food areas in gas stations, and similar areas where the floors may be walked on while wet but are free of standing water and other contaminants.
4. Exterior, Wet (EW) – Another manufacturer-declared category. In the absence of a superseding manufacturer-declared product use classification, it is generally accepted that Exterior, Wet tiles should have a DCOF greater than or equal to 0.55. Area of use examples here include pool decks, walkways, patios, and sidewalks. Typically, these tiles have a heavily textured surface or other traction-enhancing features.
5. Oils/Greases (O/G)– These products are also manufacturer-declared as suitable for this application. In the absence of a superseding manufacturer-declared product use classification, a DCOF equal to or above 0.55 is generally accepted for this category. These products will frequently include abrasive grains, heavy structure, or other traction-enhancing features such as a raised tread pattern. Area of use examples of these applications include ‘back of house’ restaurant use, food preparation areas where fats and greases are present, and areas exposed to automotive fluids.

The revision to ANSI A326.3 has had some big ramifications for the Tile industry. Most manufacturers, if not all, have started to use these classifications by including them in their technical data sheets and, in some instances, the actual boxes/cartons the tile come in. See the article on “Slip and Falls” on the TTMAC website “XXXX” and from the statistics that were given at the beginning of this article, slip & falls are a serious problem in our society and these changes help to provide better specifications which can potentially reduce these occurrences. This can mean less critical injuries, death, insurance claims, medical costs, days away from work, and other consequences.

If you require DCOF testing either in the lab or in the field, the TTMAC is able to conduct both for a fee. Please contact The TTMAC at 1 800-201-8599. Check the TTMAC website [www.ttmac.com](http://www.ttmac.com) for updates

The DCOF measurement is prevalent in Europe, meaning that it will be easier to assess product performance against tests like the DIN 51130, Testing of Floor Coverings-Determination of Anti-Slip Properties (colloquially called the “German Ramp Method”). The DIN 51130 classifications assess a tile’s suitability in a given application, and is measured on a baseline DCOF of 0.45 for wet surfaces and provides an additional classification based on increased slope (ramp) to represent potential hazard as follows:

| Corrected mean of the total acceptance angle | Classification of slip resistance |
|--|-----------------------------------|
| 6° to 10°                                    | R 9                               |
| more than 10° to 19°                         | R10                               |
| more than 19° to 27°                         | R11                               |
| more than 27° to 35°                         | R12                               |
| more than 35°                                | R13                               |

Table 3 – Assignment of the corrected mean of the total acceptance angle to slip resistance classification

| Slip Hazard Classification | Examples of work rooms and work areas   |
|----------------------------|---|
| R9                         | Entry foyers of hotels, offices and public buildings (dry); shopping centres (not food areas); hospitals; supermarket aisles; lift lobbies; interior stairs; canteens; shops; packing areas; operating theatres and other dry health service areas; school areas excluding kitchens, toilets, machine and handicraft areas.   |
| R10                        | External colonnades, walkways and pedestrian crossings; entry foyers of hotels, offices and public buildings (wet); shopping centre food courts; fast food outlets; shop/ supermarket fresh fruit and vegetable areas; toilet facilities; undercover areas in sports stadia; storage areas (food preparation); coffee & tea preparation kitchens; sales areas for unpackaged bakery and cheese product areas; health service areas not covered under R9; garages, car parks; school areas not covered under R9. |
| R11                        | External stairs and stair nosings; aircraft hangars; vehicle repair workshop bays (pits are R12); wet or dry production areas not involving oils and fats; laundries; serving counters for unpackaged meat and vegetables; florists; catering establishments, including washing-up areas; wet sterilizing rooms; beverage bottling plants; chocolate and confectionary plants (excluding sugar and cocoa production areas).   |
| R12                        | Production areas involving margarine, cooking oils, milk, butter, cocoa, sugar; meat processing areas (see also R13); vegetable processing; large catering areas; sales areas involving deep-fry and grill equipment; waste-water treatment rooms; fire stations; pickling, cleaning, hardening, galvanizing metal-working areas.   |
| R13                        | Tanneries; vegetable processing and tinning areas; fish processing and delicatessen production facilities; abattoirs and meat processing areas; cooking oil and fat processing areas.   |

## TESTING AFTER INSTALLATION & SITE TESTING

When a problem occurs in an installation, there are methods of testing the application to determine the cause. It is important to use proper testing and professionals, as installation problems tend to be complicated and may involve more than one issue. The evaluation of the test is often more important than the test itself, therefore consultants are recommended.

**Pull Tests** can be done on site to assist in determining where a bonding failure is occurring. It involves a 75 mm – 150 mm core being drilled through the tile and thin-set and down into the substrate. The core is then pulled to determine where the failure occurred. ISO 13007 will provide testing criteria providing the installation is reasonably cured (minimum 28 days), longer for larger format or impervious tiles.

**Chain Drag, steel rod, steel ball bearing** can be used to identify hollow areas, although the test cannot determine whether hollow spots occur under the tile, under the thin-set or under the substrate. Core tests may be used to further identify the problem.

**Coefficient of Friction tests** can be done on site but are dependent on maintenance, as a single cleaning may not remove residue off the tile prior to running the test. “ The BOT 3000e is a portable machine that can be used for on-site testing and is described under ANSI A 326.3 ( section 8.2 ) Caution must be exercised when interpreting the results as the slip resistance of installed tiles are affected by other things such as wear, maintenance and spills.

**Individual tile removal** can be used to identify problems, however, should be left to the professional tile contractor as interpretation is difficult.

**Site Inspections** by qualified tile inspectors are a good start to solving problem installations. Qualified professionals can see problems, often without the use of testing equipment and can recommend remedial work at the same time. The TTMAC offers a fully qualified inspection service, across the country.

**Forensic Testing** may involve chemical analysis to determine what the tile has been exposed to. It might also involve some investigation to determine what might have caused the damage. The TTMAC offers a fully qualified inspection service, across the country.

**Moisture Vapor Emission Rate** of concrete is used to determine the amount of moisture in the concrete slab and is useful in determining whether the concrete is ready to receive moisture sensitive products such as epoxy, some modified thin-sets, gypsum concrete screeds and limestone, i.e. Calcium Chloride Test.

**Test for Concrete Sealers** is a water droplet test performed in various locations that determines whether the moisture is absorbed into the concrete fast enough to indicate that the concrete is unsealed. Core tests can also be used to submit samples to a lab for inspection under a microscope.

### Measuring planarity of manufactured tiles

Any manufactured tile will likely have some warpage. As such tiles manufactured to either ISO or ASTM standards must meet specific criteria. See page 34 and 35 to review these standards

Measuring the flatness can be done two ways

1. Lay the tile face up on a flat surface. Using a gauged taper wedge measure the gap between the surface and the bottom of the tile for the measurement.
2. Place two tile back to back at 90 degrees to a flat surface. Using a gauged taper wedge measure the gap between the two tiles. Take that measurement and divide by 2 to get actual bow per tile.



## ✦ LIFE-CYCLE COST FOR TILE FLOORING IN COMMERCIAL BUILDINGS

There are several methods available to evaluate and compare the economic performance of products or systems. For this study, life-cycle cost analysis (LCCA) is used to compare 18 flooring types installed in a typical office building. For the purpose of this study, a typical office building is defined according to the commercial building characteristics included in the 2018 Commercial Buildings Energy Consumption Survey from the U.S. Energy Information Administration. The LCCA was conducted according to ASTM E917-17, Standard Practice for Measuring Life-Cycle Costs of Buildings and Building Systems.

| Material Type          | Initial Installation Cost (per sq.ft) |         | Life Cycle Cost (per sq.ft) |          | Estimated Useful Life | Cost per year (per sq.ft.) |        |        |
|------------------------|---------------------------------------|---------|-----------------------------|----------|-----------------------|----------------------------|--------|--------|
|                        | Region                                | West    | East                        | West     |                       | East                       | Canada | West   |
| Quarry Tile            |                                       | \$13.50 | \$16.50                     | \$75.28  | \$78.28               | 75 years                   | \$1.00 | \$1.04 |
| Ceramic Tile           |                                       | \$13.03 | \$16.70                     | \$74.81  | \$78.48               | 75 years                   | \$0.99 | \$1.04 |
| Porcelain Tile         |                                       | \$13.38 | \$17.50                     | \$75.16  | \$79.28               | 75 years                   | \$1.02 | \$1.05 |
| Solid Wood             |                                       | \$8.92  | \$5.00                      | \$70.70  | \$66.78               | 75 years                   | \$0.94 | \$0.89 |
| Engineered Wood        |                                       | \$7.92  | \$9.35                      | \$88.54  | \$99.83               | 25 years                   | \$1.18 | \$1.33 |
| Limestone              |                                       | \$24.30 | \$26.00                     | \$86.08  | \$87.78               | 75 years                   | \$1.15 | \$1.17 |
| Travertine             |                                       | \$24.30 | \$26.00                     | \$86.08  | \$87.78               | 75 years                   | \$1.15 | \$1.17 |
| Granite                |                                       | \$26.65 | \$28.00                     | \$88.43  | \$89.78               | 75 years                   | \$1.18 | \$1.19 |
| Marble                 |                                       | \$26.65 | \$28.00                     | \$88.43  | \$89.78               | 75 years                   | \$1.18 | \$1.19 |
| Nylon Broadloom Carpet |                                       | \$5.86  | \$4.50                      | \$163.68 | \$143.28              | 5 years                    | \$2.18 | \$1.91 |
| LVT                    |                                       | \$4.56  | \$4.56                      | \$86.58  | \$86.58               | 15 years                   | \$1.15 | \$1.15 |
| Carpet Tile            |                                       | \$5.25  | \$5.35                      | \$154.53 | \$156.03              | 5 years                    | \$2.06 | \$2.08 |
| Rigid Core             |                                       | \$6.36  | \$5.30                      | \$99.58  | \$91.28               | 15 years                   | \$1.33 | \$1.22 |
| Epoxy Terrazzo         |                                       | \$45.00 | \$45.00                     | \$75.44  | \$106.78              | 75 years                   | \$1.00 | \$1.42 |
| Laminate               |                                       | \$8.49  | \$4.75                      | \$94.00  | \$90.91               | 20 years                   | \$1.25 | \$1.21 |
| VCT                    |                                       | \$3.09  | \$3.75                      | \$81.23  | \$80.23               | 15 years                   | \$1.08 | \$1.07 |
| Sheet Vinyl            |                                       | \$7.10  | \$7.10                      | \$101.28 | \$101.28              | 15 years                   | \$1.35 | \$1.35 |

- All 75-year estimated useful life have a lifetime cleaning cost of \$61.78.
- All shorter life span materials have had removal, disposal and reinstall added for each term as well as a lifetime cleaning cost of \$61.78.

## ✿ MOVEMENT JOINTS FOR TILE INSTALLATIONS 301MJ-2025

Expansion joints and movement joints (also referred to as isolation joints) are required in both floor and wall tile installations. Expansion joints must extend through both the tile and the substrate on which the tile is applied and are designed to accommodate continuing movement in the structure caused by expansion and/or contraction due to thermal or other effects throughout the life of the building. The installation of movement joints in the opening left by the tile contractor are covered in the "Caulking and Sealants" section of the tile specification.

Concrete control joints (sometimes referred to as contraction joints) are a joint cut into the concrete surface to control the shrinkage of the concrete and the location of cracks. According to the ACI, the saw cut in the concrete slab should be to a depth of 1/4 of the thickness of the slab and should be cut into the concrete within the first 12 hours of the concrete being poured, with joint spacing 24 to 26 times the slab thickness. The saw cutting of the concrete slab is not the responsibility of the tile contractor.

Movement joints in the tile should align with the joint cuts in the slab whenever possible, and if not, a crack isolation or uncoupling membrane to be used under the tile and a control joint installed in a tile joint adjacent to the sawcut in the concrete. (Figure )

Movement joints are joints in the ceramic tile, extending through the setting materials, which are intended to minimize stresses in the bonding layer due to differential movement of the ceramic tile relative to the substrate caused by thermal expansion and contraction.

Movement joints are required around the perimeter of floors where the tile butts up against a hard surface, around columns, at the junction between horizontal and vertical surfaces, at vertical joints of changes of directions (inside corners), and at transitions that include corridors and changes in direction for example T's, L's and diagonals. Movement joints are also required in the tile field, at regular intervals in both directions, when the installation is large enough to require them.

Movement joints are also required in tile installations when the supporting slab has a crack that is treated with a crack isolation membrane. Crack isolation membrane is required to be at least the width of the tile, and a movement joint installed in the closest tile joint adjacent to the crack in the substrate.

The location, size and type of expansion joints and movement joints is the responsibility of the consultant. Exterior expansion or movement joints to be caulked with suitable sealants. For interior expansion or control joints, prefabricated expansion joints or double metal or plastic strips may be used with a suitable sealant. Prefabricated expansion joints have the advantage of protecting the tile edge, but do not allow for as much movement as a joint filled with sealant. In the case where prefabricated movement joints are used, consideration should be given to increasing the frequency of these joints by reducing the distance between them. For narrower joints of 6 mm or less, a caulked joint with the appropriate sealant that is floor rated may be used. Some prefabricated expansion joints may be recommended by the manufacturer for exterior use. In all cases for prefabricated joints, follow manufacturer's instructions for intended use.

Sealants used for movement joints must be 100% silicone, urethane, or polysulfide. Sealants should possess minimum 25% elongation and be 35 Shore hardness when cured. Certain conditions, such as in wet areas, or for use with a porous finish material, may require the use of a primer for proper adhesion of the sealant. In all cases refer to sealant manufacturer's technical data sheet for installation requirements.

Of note, latex or acrylic based caulks are not suitable for flooring applications nor for vertical applications that will be exposed to moisture or the elements.

**CONSTRUCTION JOINT**-These joints occur at a planned junction of different slab pours. Usually dowels or reinforcing steel are used to maintain horizontal alignment of the adjacent slab and keep them in the same plane. A movement joint is to be installed directly over all cold joints in the slab wherever possible. Where conditions do not allow one to install a movement joint directly over the cold joint, the use of a crack isolation membrane can be considered along with the installation of a movement joint in the tile surface as close as possible to the cold joint in the substrate. The tile that bridges the cold joint must be installed 100% on the crack isolation membrane. The project consultant should always be consulted for this type of situation.

**COLD JOINT**-The plane where two unplanned successive placements of concrete meet but do not bond cementitiously. Sometime dowels or reinforcing steel may be used to hold the concrete on both sides together, but this is not always the case. A movement joint to be installed directly over this cold joint, but the project consultant should be consulted for this type of situation.

### GENERIC MOVEMENT JOINT

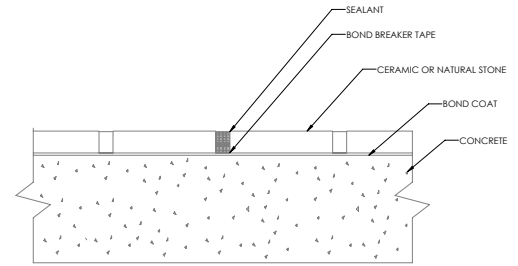

### EXPANSION JOINT A

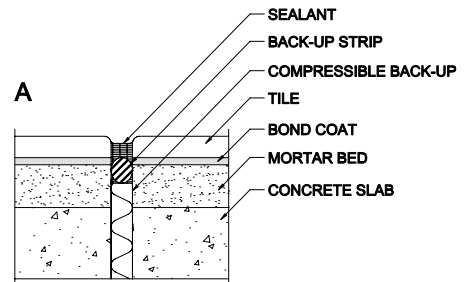

### EXPANSION JOINT B

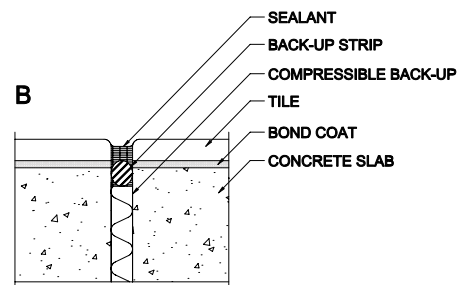

### CONTROL JOINT C1

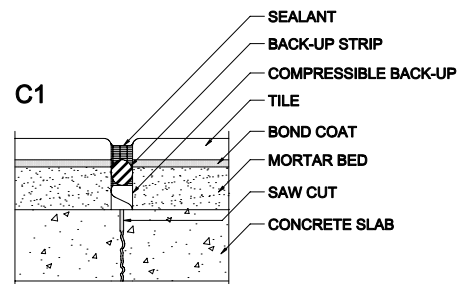

### CONTROL JOINT C2

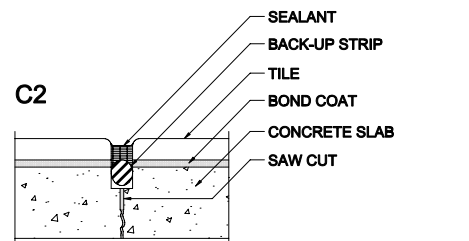

**EXPANSION JOINT** -An expansion joint in a concrete structure is a separation provided between adjacent sections to allow movement due to dimensional increases and reductions of the adjacent sections and through which some or all of the bonded reinforcement is interrupted.

**ISOLATION JOINT** - A separation between adjoining similar or dissimilar elements of a concrete structure, usually a vertical plane. Its purpose is to allow movement of individual parts of the structure without causing cracks in the concrete. Also sometimes called an expansion joint.

**STRUCTURAL JOINT** -An isolation joint intended to allow independent movement between adjoining sections of the building. Such joints are usually addressed by the insertion of a mechanical pre-made expansion joint designed into the structure by the professionals and carried through to the finished surface.

**FIELD MOVEMENT JOINT** - Spacing left in the main field of a tile installation to accommodate expected expansion and contraction of the tile, not over any subfloor joint. Distance between movement joints is dependant on the coefficient of thermal expansion of the tile and the expected temperature range that the tile will be subject to during the year. Exterior movement joints, due to greater temperature variation, will require movement joints that are wider and more frequently spaced.

**PERIMETER ISOLATION JOINT**- Spacing left around the perimeter of a tile installation when tile butts up against a surface which will prevent expansion. If the spacing will be hidden by a baseboard or wall treatment, then it can be left empty. If the spacing will be apparent, then it should be filled with a suitable flexible sealant. Minimum width of this perimeter movement joint is 6 mm.

**NON-LINEAR MOVEMENT JOINTS** - Generic movement joints or field joints, not over an existing expansion joint in the subfloor or wall. These types of joints are used where disruption of the normal tile joint pattern is not desired or when tile pattern or sizing results in joints in the tile being not in a straight line. Sealant shall meet ASTM C920 and must be approved by the sealant manufacturer for the intended application. Crack isolation membrane may be used with this application. Consult with crack isolation membrane manufacturer in this case.

All movement joints in the tile surface must be at least as wide as the movement joint in the supporting structure.

The location, width and spacing of the movement joints is the responsibility of the consultant, who is equipped with the knowledge to assess the various conditions encountered on the project such as coefficient of expansion of the tiles, movement due to wind loads, seismic activity, slab deflection, etc. which will allow the consultant to make the calculations which determine the placement of movement joints in the tile assembly.

Examples of coefficient of expansion are included in table below. However, tile manufacturers should be able to provide the precise COE for their product, and these values should be consulted for the calculations.

As far as the tile assembly, the expected movement due to thermal expansion can be calculated by a formula which is:

$$\text{Expected movement} = \text{coefficient of expansion of the tile} \times \text{expected temperature variation} \times \text{distance between the movement joints.}$$

The width of the movement joint should be four times the expected movement, and as a result, the sealant required needs to have an expansion and/or contraction of 25% of the joint width. Good practice for the sealant installation recommends that one should avoid three-sided adhesion, either by use of a backer rod or a bond breaker tape if a backer rod cannot be used. Narrow movement joints may prevent the use of a backer rod or bond breaker tape. Narrow joints where bond breaker tape cannot be used, such as 3 mm width, can be filled with flexible sealant without any foreseeable issue due to limited expected movement. Minimum movement joint is recommended to be 3 mm. Maximum width is dependant on sealant manufacturer's instructions. Ideal profile of movement joint is considered 2:1 (width:height) hourglass profile.

Today's modern tile manufacturing processes give us products with very precise tolerances. Many rectified tile formats are designed modular with a precise joint width in mind. So often it is not practical to have to modify a tile pattern to accommodate movement joints which are wider than the intended tile joint.

So, using the above information, we can derive a formula which can give us the maximum spacing between movement joints for a desired joint width and expected temperature variation. This formula would be:

$$\text{Maximum Spacing} = \text{Movement joint width} / 4 \times (\text{Coefficient of expansion} \times \text{expected temperature variation})$$

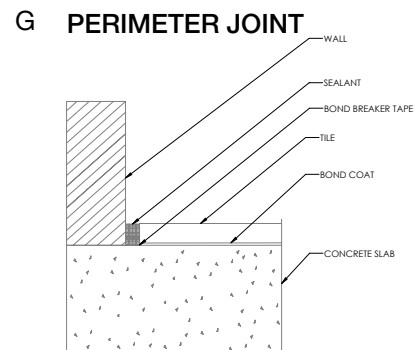
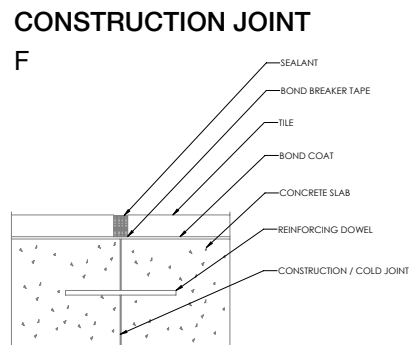
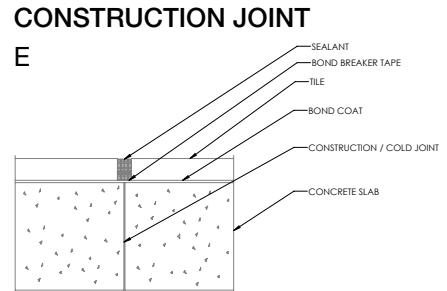
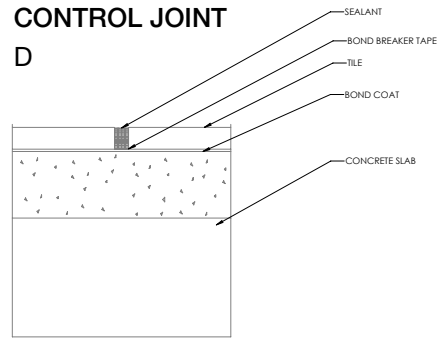

So, for a 3 mm wide joint, a coefficient of expansion of .000007 mm/mm/°C and an expected temperature variation of 20°C, the formula  
 Max spacing = 3 mm / 4 X (.000007 mm/mm/C x 20 °C), or 5,357 mm between movement joints.

In order to facilitate the determination of maximum spacing between movement joints, the TTMAC has produced a table showing maximum spacing for different desired joint widths, expected temperature variations, and different coefficient of expansions.

The general rule is with higher expected temperature variations, the wider the required joint and/or the closer spacing of the movement joints is required.

TTMAC has a recommended maximum spacing between movement joints for interior installations on slab on grade with low temperature variations not exceeding 20 °C of 7500 mm spacing, irrespective of COE values, due to limits on the capacity of the mortar to flex enough, for the expected movement without losing the bond.

For suspended slab, with potential deflection and vibration this spacing should be reduced. For areas subject exposed to direct sunlight such as under skylights or at transparent curtain walls, the spacing should be reduced.

For exterior areas, subject to wider temperature variations, movement joint spacings should be reduced, and joint width increased. Maximum suggested spacing not to exceed 5625 mm for 40 °C variation, 3750 mm for 60 °C variation, and 2500 mm for 80 °C variation.

### PREFABRICATED MOVEMENT JOINT

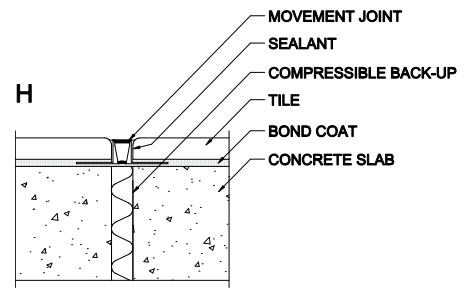

### Sample Coefficients of Thermal Expansion

| Material       | Coefficient of expansion (COE) X 10-5 mm/mm/°C |
|----------------|--|
| Quarry Tile    | +/- 5.9  |
| Porcelain Tile | +/- 7.8  |
| Concrete       | +/- 10.3                                       |
| Marble         | +/- 10.1                                       |
| Limestone      | +/- 5.9  |
| Granite        | +/- 7.9  |

### PREFABRICATED PERIMETER JOINT

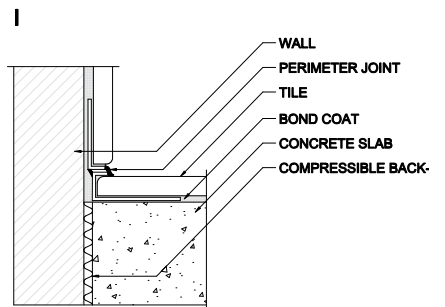

| MAXIMUM MOVEMENT JOINT SPACING (mm) |      |       |       |       |      |      |       |       |      |      |       |       |       |      |       |       |       |       |
|-------------------------------------|------|-------|-------|-------|------|------|-------|-------|------|------|-------|-------|-------|------|-------|-------|-------|-------|
| Temperature variance °C             | From | 0     | to    | 20    | From | 20   | to    | 40    | From | 40   | to    | 60    |       | From | 60    | to    | 80    |       |
| Movement joint width (mm)           | 3    | 4.5   | 6     | 10    | 3    | 4.5  | 6     | 10    | 3    | 4.5  | 6     | 10    | 12    | 3    | 4.5   | 6     | 10    | 12    |
| COE ( X 10-6 mm/mm/°C)              |      |       |       |       |      |      |       |       |      |      |       |       |       |      |       |       |       |       |
| 5                                   | 7500 | 7500* | 7500* | 7500* | 3750 | 5625 | 5625* | 5625* | 2500 | 3750 | 3750* | 3750* | 3750* | 1875 | 2500* | 2500* | 2500* | 2500* |
| 6                                   | 6250 | 7500* | 7500* | 7500* | 3125 | 4688 | 5625* | 5625* | 2083 | 3125 | 3750* | 3750* | 3750* | 1563 | 2344  | 2500* | 2500* | 2500* |
| 7                                   | 5357 | 7500* | 7500* | 7500* | 2679 | 4018 | 5357  | 5625* | 1786 | 2679 | 3571  | 3750* | 3750* | 1339 | 2009  | 2500* | 2500* | 2500* |
| 8                                   | 4688 | 7031  | 7500* | 7500* | 2344 | 3516 | 4688  | 5625* | 1563 | 2344 | 3125  | 3750* | 3750* | 1172 | 1758  | 2344  | 2500* | 2500* |

\* maximum recommended spacing

NOTES: Above applies to slab on grade

#### Spacing to be reduced for:

- Areas under skylights or windows
- Installation on suspended slabs
- Exterior Installations

### 3 EXAMPLES OF NON-LINEAR JOINT CONFIGURATIONS

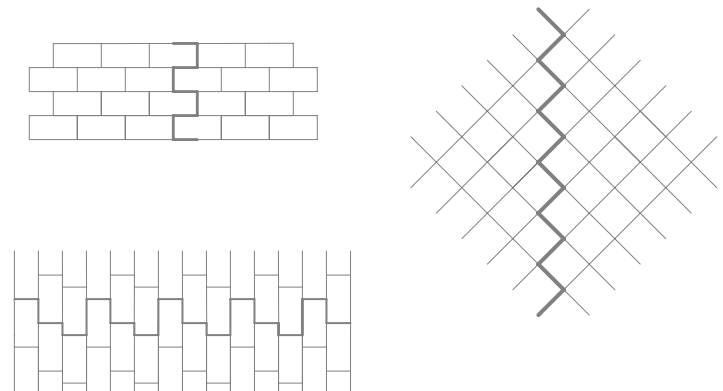

# TILE INSTALLED ON CEMENT MORTAR OVER MASONRY OR CONCRETE WALLS

## 302W-2025 INTERIOR/EXTERIOR

### SUITABLE SUBSTRATES

- Concrete or masonry.

### MATERIALS

- **TILE** – Interior and dry areas: All tile types as recommended by the manufacturer. Exterior: Frost resistant materials only.
- **SCRATCH COAT** (7 mm minimum) See Tile Guide Specification Section Mixes 2.9.2.1.
- **MORTAR BED** (20 mm+) See Tile Guide Specification Section Mixes 2.9.2.3.
- **MEMBRANE** – ANSI A118.10 All types as recommended by the manufacturer.
- **BOND COAT** – Interior: Latex-Portland cement mortar (minimum acceptable standard ANSI A118.4 or ISO 13007 C2) epoxy mortar (minimum acceptable standard ANSI A118.3 or ISO 13007 R1), dry-set mortar (minimum acceptable standard ANSI A118.1 or ISO 13007 C1), organic adhesives (minimum acceptable standard ANSI A136.1 or ISO 13007 D1). Exterior: Single or two component liquid latex-Portland cement mortar (minimum specification required ANSI A118.4 or ISO 13007 C2S1).
- **GROUT** – Interior: Commercial Portland cement, Latex-Portland cement grout (minimum acceptable standard ANSI A118.6 or ISO 13007 CG1), epoxy (minimum acceptable standard ANSI A118.3 or ISO 13007 RG), or RTU grout. Exterior: Latex- Portland cement grout (minimum acceptable standard ANSI A118.6 or ISO 13007 CG1).

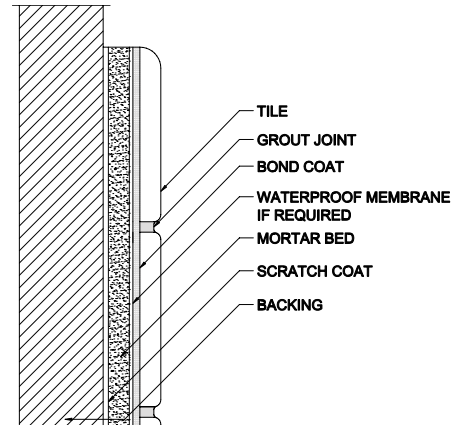

### APPLICATION

- Apply scratch coat and allow to cure a minimum of 24 hours at 20°C. Apply mortar bed to required thickness in an even plane. Finished tolerance of mortar bed not to exceed 6 mm in 3000 mm or 2 mm in 300 mm. Allow up to 72 hours to cure. For large format tile where any side is greater than 380 mm surface variation should not exceed 3 mm in 3000 mm and 1,5 mm in 600 mm. Apply bond coat to mortar bed surface. Use proper notched trowel to ensure adequate bond. Place the tiles firmly into the wet bond coat. Push the tiles back and forth in a direction perpendicular to trowel lines, to collapse the mortar ridges and to help achieve maximum coverage. Ensure proper contact between mortar, tile and substrate by periodically lifting a few tiles to check for acceptable coverage. Use sufficient bond coat to ensure minimum 95% contact on exterior installations and wet areas (it may be necessary to flat back and notch back trowel the tile in order to meet this requirement) and minimum 80% on interior dry installations. Remove excess mortar from the joint areas so that at least 2/3 of the tile depth is available for grouting. Allow bond coat to cure. Force grout into the joints with a rubber grout float. Make sure all joints are well-compacted and free of voids and gaps. Remove excess grout from the tile surface and clean.

### LIMITATIONS

- Manufacturer's recommendations to be followed. Exterior tile installations not to be attempted with a temperature of less than 12°C unless otherwise stated by manufacturer. Do not use paper-back mounted tile, or mesh-back mounted tile for exterior use or in locations of extreme moisture should not be used unless the manufacturer guarantees that the material is suitable for this type of installation.

### OTHER CONSIDERATIONS

- Latex additive is recommended for modification of scratch coat, mortar bed and Portland cement bond coat. Follow manufacturer's recommendations. Where job conditions require additional thickness, allow 24 hours cure between coats.
- Tile used on exterior applications to be frost resistant.
- It is recommended to back butter stone or agglomerated stone in wet indoor and exterior installations.
- Refer to Notes For the Professional and 301MJ-2019-2021.
- Waterproofing membrane if required must be specified. (ANSI A118.10) Follow manufacturer's recommendations.
- For external installations It is suggested to leave last 300 mm of vertical grout joints ungrouted at every 600 mm to allow moisture to escape at the bottom of the wall.
- Latex Portland cement mortars may require 14 – 60 days cure before exposure to water. Verify with the manufacturer the correct cure time required. Alternatively, to reduce the curing time required, a rapid set mortar may be more suitable.
- For external installation proper flashing is required to prevent water ingress between backing wall and the tile

# TILE INSTALLED OVER MASONRY OR CONCRETE WALLS - THIN-SET METHOD

## 303W-2025 INTERIOR/EXTERIOR

### SUITABLE SUBSTRATES

- Concrete or masonry.

### MATERIALS

- **TILE** – **Interior and dry areas:** All tile types as recommended by the manufacturer. **Exterior:** Frost resistant materials only.
- **SLIGHT LEVELLING COAT**, if required. – **Interior:** Latex-Portland cement mortar (minimum acceptable standard ANSI A118.4 or ISO 13007 C2) or dry-set mortar (minimum acceptable standard ANSI A118.1 or ISO 13007 C1). **Exterior:** Latex-Portland cement mortar.
- **MEMBRANE** – ANSI A118.10 All types as recommended by the manufacturer.
- **BOND COAT** – **Interior:** Latex-Portland cement mortar or dry-set mortar. **Exterior:** Single or two component liquid latex-Portland Cement mortar (minimum acceptable standard ANSI A118.4 or ISO 13007 C2S1).
- **GROUT** – **Interior:** Commercial Portland cement, Latex-Portland cement grout (minimum acceptable standard ANSI A118.6 or ISO 13007 CG1), epoxy (minimum acceptable standard ANSI A118.3 or ISO 13007 RG). **Exterior:** Latex-Portland cement grout (minimum acceptable standard ANSI A118.6 or ISO 13007 CG1).

### APPLICATION

- Surface variation not to exceed 6 mm in 3000 mm or 2 mm in 300 mm. For large format tile where any side is greater than 380 mm surface variation should not exceed 3 mm in 3000 mm and 1.5 mm in 600 mm. Apply levelling coat if required. Apply bond coat to substrate surface. Use proper notched trowel to ensure adequate bond. Place the tiles firmly into the wet bond coat. Push the tiles back and forth in a direction perpendicular to trowel lines, to collapse the mortar ridges and to help achieve maximum coverage. Ensure proper contact between mortar, tile and substrate by periodically lifting a few tiles to check for acceptable coverage. Use sufficient bond coat to ensure minimum 95% contact on exterior installations and wet areas (it may be necessary to flat back and notch back trowel the tile in order to meet this requirement) and minimum 80% on interior dry areas. Remove excess mortar from the joint areas so that at least 2/3 of the tile depth is available for grouting. Allow bond coat to cure. Force grout into the joints with a rubber grout float. Make sure all joints are well-compacted and free of voids and gaps. Remove excess grout from the tile surface and clean.

### LIMITATIONS

- Manufacturer's recommendations to be followed.
- Exterior tile installations not to be attempted with a temperature of less than 12°C unless otherwise stated by mortar manufacturer. Do not use paper-back mounted tile or mesh-back mounted tile for exterior use or in locations of extreme moisture should not be used unless the manufacturer guarantees that the material is suitable for this type of installation.

### OTHER CONSIDERATIONS

- Tile used on exterior applications to be frost resistant.
- It is recommended to flat back and notch back trowel stone or agglomerated stone in wet indoor or exterior installations.
- Refer to Notes For The Professional and 301MJ-2019-2021.
- Waterproofing membrane if required must be specified. (ANSI A118.10). Follow manufacturer's recommendations.
- It is suggested for exterior installations to leave at least the bottom 13 mm of vertical grout joints ungrouted at every 600 mm to allow moisture to escape at the bottom of the wall, or leave bottom horizontal joint empty
- Latex Portland cement mortars may require 14 – 60 days cure before exposure to water. Verify with the manufacturer the correct cure time required. Alternatively, to reduce the curing time required, a rapid set mortar may be more suitable.
- For external installation proper flashing is required to prevent water ingress between backing wall and the tile

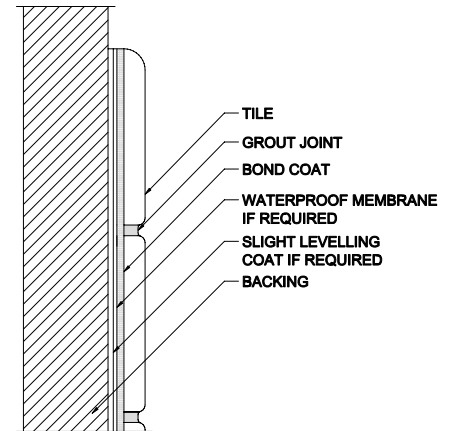

# TILE INSTALLED OVER GYPSUM BOARD - THIN-SET METHOD

## 304W-2025

### DRY AREAS ONLY

### SUITABLE SUBSTRATES

- Gypsum board (13 mm minimum)
- Wood or metal strapping, or studs. Maximum 406 mm o.c.

### MATERIALS

- TILE - All tile types as recommended by the manufacturer
- TAPE – 51 mm drywall tape
- BOND COAT – Latex-Portland cement mortar or organic adhesive Type I or Type II (minimum acceptable standard ANSI A136.1 or ISO 13007 D1).
- GROUT – Epoxy grout (minimum acceptable standard ANSI A118.3 or ISO 13007 RG) or latex-Portland cement grout (minimum acceptable standard ANSI A118.6 or ISO 13007 CG1).

### APPLICATION

- Gypsum board to be stable, plumb, square and screwed to studs. All joints to be taped and sanded, if necessary. Surface variation not to exceed 6 mm in 3000 mm or 2 mm in 300 mm. For large format tile where any side is greater than 380 mm, surface variation should not exceed 3 mm in 3000 mm and 1.5 mm in 600 mm. Apply bond coat to substrate surface. Use proper notched trowel to ensure adequate bond. Place the tiles firmly into the wet bond coat. Push the tiles back and forth in a direction perpendicular to trowel lines, to collapse the mortar ridges and to help achieve maximum coverage. Ensure proper contact between mortar, tile and substrate by periodically lifting a few tiles to check for acceptable coverage. Use sufficient bond coat to ensure minimum 80% contact in dry areas. Remove excess mortar from the joint areas so that at least 2/3 of the tile depth is available for grouting. Allow bond coat to cure. Force grout into the joints with a rubber grout float. Make sure all joints are well-compacted and free of voids and gaps. Remove excess grout from the tile surface and clean.

### LIMITATIONS

- Organic adhesives (as known as dispersion adhesives)– are not recommended for use in areas exposed to temperatures above 60°C. Type of organic adhesives to be recommended by the manufacturer.
- Organic adhesives Manufacturer's recommendations must be followed for use and suitability with non-absorbent tile and maximum tile dimensions.
- The use of latex cement mortars may require that the substrate be primed. Consult manufacturers written instructions.

### OTHER CONSIDERATIONS

- Heavy lug tiles are not recommended, but if used, to be set only with latex cement mortars.
- It is recommended to flat back and notch back trowel stone or agglomerated stone
- Special care to be taken when installing tile thicker than 13 mm to prevent slippage or debonding.
- Refer to Notes For The Professional and 301MJ-2025.
- This system not to be used in wet or exterior areas such as showers, bath surrounds, steam rooms or exterior installations.

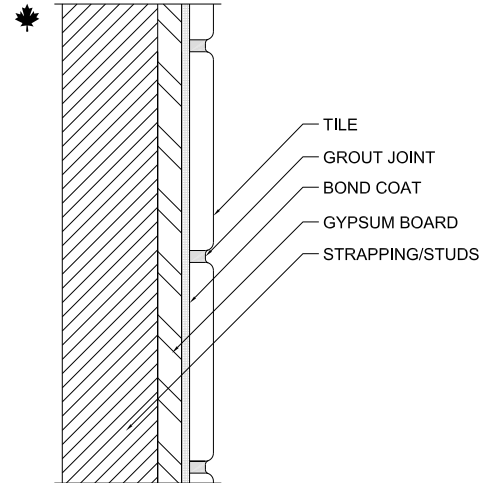

# TILE INSTALLED ON CEMENTITIOUS BACKER UNIT (CBU) OR FIBRE CEMENT BACKER BOARD – THIN-SET METHOD/WALLS 305W-2025

## DETAIL A - INTERIOR WET/DRY AREAS AND EXTERIOR USE

### SUITABLE SUBSTRATES

- Cementitious backer units (13 mm minimum) or fibre cement backer board (11 mm minimum)
- Wood studs for interior use only or metal studs maximum 406 mm o.c.

### MATERIALS

- VAPOUR RETARDER – 6 mils polyethylene film – Required in exterior and wet areas
- CEMENTITIOUS BACKER UNIT (CBU) – minimum 13 mm thick meeting ANSI A 118.9 or nominal 11 mm thick fibre-cement backer board meeting ASTM C1288.
- TILE – **Interior:** Usually non-vitreous glazed wall tile, but suitable for other types of ceramic tile and mosaic. Consult with manufacturer. **Exterior:** Use frost resistant materials only.
- TAPE – 51 mm fibre-mesh
- SLIGHT LEVELLING COAT – if required.
- MEMBRANE – ANSI A118.10 All types as recommended by the manufacturer.
- BOND COAT – **Interior:** Latex-Portland cement mortar (minimum acceptable standard ANSI A118.4 or ISO 13007 C2) or dry-set mortar (minimum acceptable standard ANSI A118.1 or ISO 13007 C1). **Exterior:** Single or two component liquid latex-Portland cement mortar (minimum acceptable standard ANSI A118.4 or ISO 13007 C2S1).
- GROUT – Single or two component – **Interior:** Commercial Portland cement, Latex-Portland (minimum specification required ANSI A118.6 or ISO 13007 CG1), epoxy. **Exterior:** Latex-Portland cement grout (minimum acceptable standard ANSI A118.6 or ISO 13007 CG1).

### APPLICATION

- Cementitious backer unit (CBU) or Fiber Cement backer board must be stable, plumb, square and screwed to studs with corrosion resistant fasteners. Surface variation in the backing not to exceed 6 mm in 3000 mm or 2 mm in 300 mm. For large format tile where any side is greater than 380 mm, surface variation should not exceed 3 mm in 3000 mm and 1.5 mm in 600 mm. Apply levelling coat if required. All joints must be taped with 51 mm fibre-mesh tape, filled with a dry-set or latex mortar and sanded smooth if required.. Apply bond coat to mortar bed surface. Use proper notched trowel to ensure adequate bond. Place the tiles firmly into the wet bond coat. Push the tiles back and forth in a direction perpendicular to trowel lines, to collapse the mortar ridges and to help achieve maximum coverage. Ensure proper contact between mortar, tile and substrate by periodically lifting a few tiles to check for acceptable coverage. Use sufficient bond coat to ensure minimum 95% contact on exterior installations and wet areas (it maybe necessary to flat back and notch back trowel the tile in order to meet this requirement) and minimum 80% on interior dry areas. Remove excess mortar from the joint areas so that at least 2/3 of the tile depth is available for grouting. Allow bond coat to cure. Force grout into the joints with a rubber grout float. Make sure all joints are well-compacted and free of voids and gaps. Remove excess grout from the tile surface and clean.

### LIMITATIONS

- Manufacturer's recommendations must be followed.
- Exterior tile installations should not be attempted when temperature is less than 12°C unless otherwise stated by manufacturer. Do not use paperback or mesh-back mounted tile for exterior use or in locations of extreme moisture unless the manufacturer guarantees that the material is suitable for this type of installation.
- All requirements for exterior applications must be met.

Continued

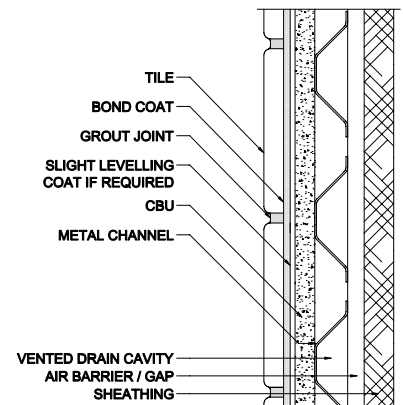
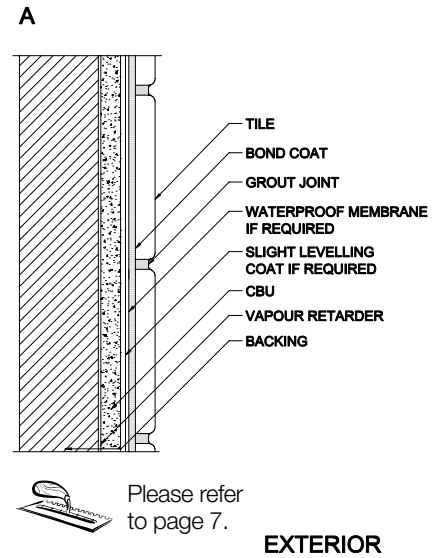

#### OTHER CONSIDERATIONS

- Spacing and minimum gauge of steel studs as per instructions of manufacturer of cementitious backer unit (CBU). On exterior installation, drill approximately 6 mm weep holes in grout joints at the bottom of the wall to prevent spalling of cementitious backer unit (CBU) due to freeze-thaw action or follow manufacturers recommendations.
- It is recommended to flat back and notch back trowel stone or agglomerated stone.
- Waterproofing membrane if required must be specified. (ANSI A118.10) Follow manufacturer's recommendations.
- Special care must be taken when installing tile thicker than 13 mm to prevent slippage or debonding.
- Tile used on exterior applications must be frost resistant.
- Refer to Notes For The Professional and 301MJ-2025.
- For high use showers (hotels, gang showers, sports facilities, etc.) a waterproofing membrane must be used. Refer to detail 319SR-2025.
- Insulation and vapour retarder location to be specified by consultant.
- Refer to local codes and bylaws with respect to vented drain cavity for exterior applications.
- All openings and cuts must be treated to ensure waterproof integrity.
- For exterior installations It is suggested to leave bottom 13 mm of vertical grout joints ungrouted at every 600 mm to allow moisture to escape at the bottom of the wall.
- Latex Portland cement mortars may require 14 – 60 days cure before exposure to water. Verify with the manufacturer the correct cure time required. Alternatively, to reduce the curing time required, a rapid set mortar may be more suitable.
- Backing support to be designed and detailed by the consultant.
- For external installation proper flashing is required to prevent water ingress between backing wall and the tile

# TILE INSTALLED ON COATED GLASS MAT BACKER BOARD 305W-2025

## DETAIL B - INTERIOR WET/DRY AREAS

### SUITABLE SUBSTRATES

- Coated glass mat backer board – minimum 13 mm thick. (ASTM C1178).
- Wood or metal studs, maximum 406 mm o.c.

### MATERIALS

- Coated glass mat backer board – minimum 13 mm thick. (ASTM C1178).
- TILE – Interior: Usually non-vitreous glazed wall tile, but suitable for other types of ceramic tile and mosaic. Consult with manufacturer
- TAPE – 51 mm fibre-mesh.
- BOND COAT – Latex-Portland cement grout (minimum acceptable standard ANSI A118.6 or ISO 13007 CG1) Type 1 organic adhesive (for porosity only) (minimum acceptable standard ANSI A136.1 or ISO 13007 D1).
- GROUT – Latex-Portland cement grout (minimum acceptable standard ANSI A 118.6 or ISO 13007 CG1), epoxy grout (minimum acceptable standard ANSI A 118.3 or ISO 13007 RG).

### APPLICATION

- Attach coated glass mat backer board to studs with corrosion resistant fasteners and shall be spaced 150 mm o.c. with coated grey side away from the studs and can be applied either parallel or perpendicular to framing. Drive fasteners flush with coated surface. Do not counter-sink. Surface variation in the backing not to exceed 6 mm in 3000 mm or 2 mm in 300 mm . For large format tile where any side is greater than 380 mm surface variation should not exceed 3 mm in 3000 mm and 1.5 mm in 600 mm. Apply bond coat to backer board surface. Use proper notched trowel to ensure adequate bond. Place the tiles firmly into the wet bond coat. Push the tiles back and forth in a direction perpendicular to trowel lines, to collapse the mortar ridges and to help achieve maximum coverage. Ensure proper contact between mortar, tile and substrate by periodically lifting a few tiles to check for acceptable coverage. Use sufficient bond coat to ensure minimum 95% contact in wet areas, and 80% contact in dry areas. Remove excess mortar from the joint areas so that at least 2/3 of the tile depth is available for grouting. Allow bond coat to cure. Force grout into the joints with a rubber grout float. Make sure all joints are well-compacted and free of voids and gaps. Remove excess grout from the tile surface and clean.

### LIMITATIONS

- Follow manufacturer's recommendations. Coated glass mat backer board not to be used where prolonged exposure to heat exceeds 52°C and not to be used for exterior use unless recommended by the manufacturer. It is not recommended for use with passive solar heat systems. Maximum tile size is 356 mm x 356 mm x 10 mm thick. Do not apply directly over concrete or masonry block.
- Do not use paper back or mesh back mounted tile in wet areas unless the manufacturer guarantees that the material is suitable for this type of installation.

### OTHER CONSIDERATIONS

- Movement joints, spacing and minimum gauge of steel studs as per manufacturer's instructions of coated glass mat backer board.
- Waterproofing membrane if required must be specified. (ANSI A118.10) Follow manufacturer's recommendations.
- All openings and cuts must be treated to ensure waterproof integrity.
- Tile used on exterior applications must be frost resistant.
- It is recommended to flat back and notch back trowel stone or agglomerated stone.
- Refer to Notes For The Professional and 301MJ-2025.
- A surface waterproofing membrane or vapour retarder not to be used behind coated glass mat backer board.
- For high use showers (hotels, gang showers, sports facilities, etc.) a waterproofing membrane shall be used on the side to receive tile. Refer to Detail 319SR-2025.
- Latex Portland cement mortars may require 14 – 60 days cure before exposure to water. Verify with the manufacturer the correct cure time required. Alternatively, to reduce the curing time required, a rapid set mortar may be more suitable.

B

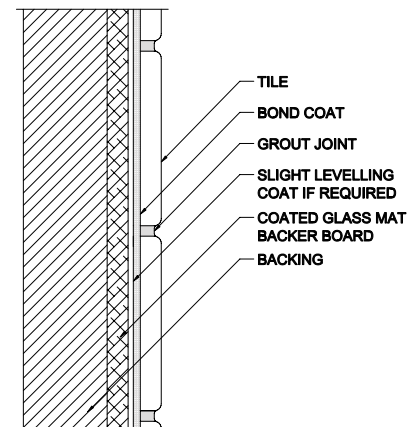

# TILE INSTALLED OVER CEMENTITIOUS BACKER UNIT (CBU) 306W-2025

## DETAIL A - ON BATH TUB/WALLS - THIN-SET METHOD INTERIOR ONLY

### SUITABLE SUBSTRATES

- Cementitious backer unit (CBU) – Minimum 13 mm thick (ANSI A118.9) or nominal 11 mm thick fibre-cement backer board meeting ASTM C1288.
- Wood or metal studs, maximum 406 mm o.c.

### MATERIALS

- VAPOUR RETARDER – 6 mils polyethylene film
- CEMENTITIOUS BACKER UNIT (CBU) – Minimum 13 mm thick (ANSI A118.9) or nominal 11 mm thick fibre-cement backer board meeting ASTM C1288.
- TILE – meeting ANSI A137.1, A137.2, A137.3, and for areas of use as recommended by the tile manufacturer
- TAPE – 51 mm fibre-mesh
- MEMBRANE – ANSI A118.10 All types as recommended by the manufacturer.
- BOND COAT – Latex-Portland cement mortar (minimum acceptable standard ANSI A118.4 or ISO 13007 C2) or Type 1 organic adhesive when recommended by the manufacturer (minimum acceptable standard ANSI A136.1 or ISO 13007 D1).
- GROUT – Latex-Portland cement grout (minimum acceptable standard ANSI A118.6 or ISO 13007 CG1) or epoxy grout (minimum acceptable standard ANSI A118.3 or ISO 13007 RG).
- SEALANT – Silicone rubber or prefabricated movement joint (PMJ).

### APPLICATION

- Attach cementitious backer unit (CBU) to studs with corrosion resistant fasteners 150 mm o.c. Surface variation in the backing not to exceed 6 mm in 3000 mm or 2 mm in 300 mm. For large format tile where any side is greater than 380 mm, surface variation should not exceed 3 mm in 3000 mm and 1,5 mm in 600 mm. Leave 3 mm space around perimeter of each board. Leave 6 mm space between bottom of tile and bath to allow for stud shrinkage and bath deflection during filling or emptying. All joints to be taped with 51 mm fibre-mesh tape. Fill with dry-set or latex mortar and sand if needed.
- Apply waterproofing membrane if required as per manufacturers written instructions.
- Apply bond coat to backer board. Use proper notched trowel to ensure adequate bond. Place the tiles firmly into the wet bond coat. Push the tiles back and forth in a direction perpendicular to trowel lines, to collapse the mortar ridges and to help achieve maximum coverage. Ensure proper contact between mortar, tile and substrate by periodically lifting a few tiles to check for acceptable coverage. Use sufficient bond coat to ensure minimum 95% contact in wet areas (it may be necessary to flat back and notch back trowel the tile in order to meet this requirement) and minimum 80% on interior dry areas. Remove excess mortar from the joint areas so that at least 2/3 of the tile depth is available for grouting. Allow bond coat to cure.
- Force grout into the joints with a rubber grout float. Make sure all joints are well-compacted and free of voids and gaps. Remove excess grout from the tile surface and clean.

### LIMITATIONS

- Manufacturer's recommendations must be followed.
- Do not use paper-back or mesh-back mounted tile for exterior use or in locations of extreme moisture unless the manufacturer guarantees that the material is suitable for this type of installation.

### OTHER CONSIDERATIONS

- This detail may be used with water-resistant gypsum board provided that a suitable waterproofing membrane is installed over gypsum board prior to application. (ANSI A118.10)
- Prefabricated movement joints (PMJ) may be used in place of sealant, where showing on drawings or where two planes meet.
- Refer to Notes For The Professional and 301MJ-2025.
- It is recommended to back butter stone or agglomerated stone.
- Refer to Notes For The Professional and 301MJ-2025.
- For high use showers (hotels, gang showers, sports facilities etc.) a waterproofing membrane shall be used.
- All openings and cuts must be treated to ensure waterproof integrity.
- Waterproofing membrane if required must be specified. (ANSI A118.10) Follow manufacturer's recommendations.
- For defective substrates fill tub with water prior to applying caulking to tub sill.

Continued

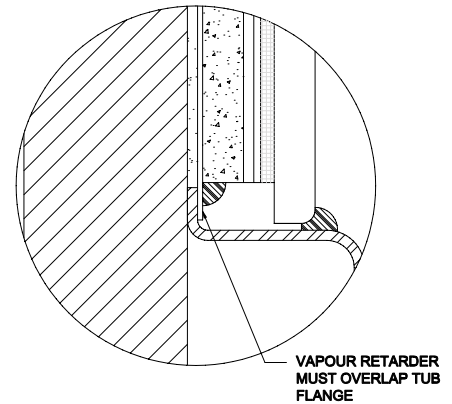
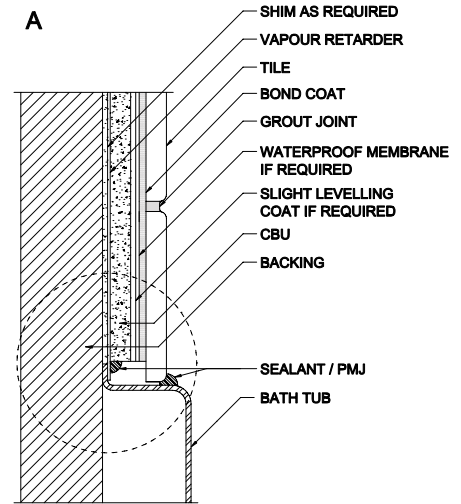

# TILE INSTALLED OVER COATED GLASS MAT BACKER BOARD 306W-2025

## DETAIL B - ON BATH TUB/WALLS – THIN-SET METHOD INTERIOR ONLY

### SUITABLE SUBSTRATES

- Coated glass mat backer board – minimum 13 mm thick (ASTM C1178).
- Wood or metal studs, maximum 406 mm o.c.

### MATERIALS

- TILE: Interior: Usually non-vitreous glazed wall tile, but suitable for other types of ceramic tile and mosaic. Consult with manufacturer
- TAPE – 51 mm wide fibre-mesh tape.
- BOND COAT – Latex-Portland cement mortar or Type 1 organic adhesive when recommended by manufacturer (minimum acceptable standard ANSI A136.1 or ISO 13007 D1).
- GROUT – Latex-Portland cement grout (minimum acceptable standard ANSI A118.6 or ISO 13007 CG1) or epoxy grout (minimum acceptable standard ANSI A118.3 or ISO 13007 RG).
- SEALANT – Silicone rubber or prefabricated movement joint (PMJ).

### APPLICATION

- Attach coated glass mat backer board to studs with corrosion resistant screws or nails . and can be applied either parallel or perpendicular to framing . Fasteners shall be spaced 150 mm o.c. with coated grey side away from the studs. Leave 6 mm space between bottom of tile and bath to allow for stud shrinkage and bath deflection during filling and emptying. Drive fasteners flush with coated surface. Do not countersink. Surface variation in the backing not to exceed 6 mm in 3000 mm or 2 mm in 300 mm. For large format tile where any side is greater than 380 mm (15 in) , surface variation should not exceed 3 mm in 3000 mm and 1,5 mm in 600 mm., Tape joints with 51 mm fibre-mesh tape, fill with a dry-set or latex mortar. Do not sand coated glass mat backer board unless a waterproofing membrane is used after sanding. Apply levelling coat if required. Apply bond coat to mortar bed surface. Use proper notched trowel to ensure adequate bond. Place the tiles firmly into the wet bond coat. Push the tiles back and forth in a direction perpendicular to trowel lines, to collapse the mortar ridges and to help achieve maximum coverage. Ensure proper contact between mortar, tile and substrate by periodically lifting a few tiles to check for acceptable coverage. Use sufficient bond coat to ensure minimum 95% contact in wet areas (it may be necessary to flat back and notch back trowel the tile in order to meet this requirement) . Remove excess mortar from the joint areas so that at least 2/3 of the tile depth is available for grouting. Allow bond coat to cure. Force grout into the joints with a rubber grout float. Make sure all joints are well-compacted and free of voids and gaps. Remove excess grout from the tile surface and clean.

### LIMITATIONS

- Follow manufacturer's recommendations. Coated glass mat backer board should not be used where prolonged exposure to heat exceeds 52°C. It is not recommended for use with passive solar heat systems. Maximum tile size is 356 mm x 356 mm x 10 mm. Do not apply directly over concrete or masonry block. Do not use paper-back or mesh-back mounted tile in locations of extreme moisture unless the manufacturer guarantees that the material is suitable for this type of installation. A surface waterproofing membrane or vapour retarder not to be used behind coated glass mat backer board.

### OTHER CONSIDERATIONS

- Movement joints, spacing and minimum gauge of steel studs as per manufacturer's instructions of coated glass mat backer board.
- Prefabricated movement joints (PMJ) may be used in place of sealant, where shown on drawings where two planes meet.
- All openings and cuts must be treated to ensure waterproof integrity.
- It is recommended to flat back and notch back trowel stone or agglomerated stone
- Refer to Notes For The Professional and 301MJ-2025.
- Latex Portland cement mortars may require 14 – 60 days cure before exposure to water. Verify with the manufacturer the correct cure time required. Alternatively, to reduce the curing time required, a rapid set mortar may be more suitable.
- For defective substrates fill tub with water prior to applying caulking to tub sill.

B

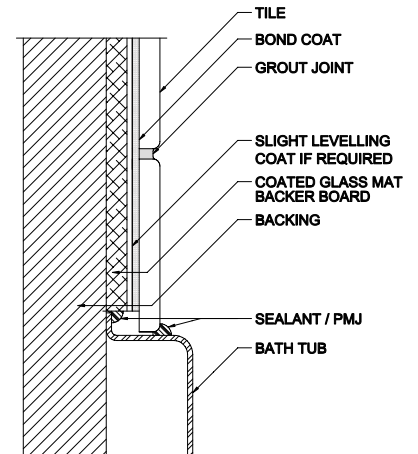

# ★ TILE INSTALLED OVER FOAM CORE BACKER BOARD 306W-2025

## DETAIL C - ON BATH TUB/WALLS – THIN-SET METHOD INTERIOR ONLY

### SUITABLE SUBSTRATES

- Foam Core backer board – minimum 12.5mm thick (ANSI A118.18).
- Wood or metal studs, maximum 406 mm o.c.

### MATERIALS

- TILE: Interior: Usually non-vitreous glazed wall tile, but suitable for other types of ceramic tile and mosaic. Consult with manufacturer
- Sealing Edge/Joint membrane – min. 50 mm polyethylene/polypropylene
- BOND COAT – Latex-Portland cement mortar (minimum acceptable standard ANSI A118.4 or ISO 13007 C2) or dry-set mortar (minimum acceptable standard ANSI A118.1 or ISO 13007 C1).
- GROUT – Latex-Portland cement grout (minimum acceptable standard ANSI A118.6 or ISO13007 CG1) or epoxy grout (minimum acceptable standard ANSI A118.3 or ISO 13007 RG).
- SEALANT – Silicone rubber or prefabricated movement joint (PMJ).

### APPLICATION

- Attach Foam Core backer board to studs with corrosion resistant screws or nails and can be applied either parallel or perpendicular to framing Fasteners shall be spaced 150 mm o.c. with coated grey side away from the studs. Leave 6 mm space between bottom of tile and bath to allow for stud shrinkage and bath deflection during filling, and emptying. Drive fasteners flush with coated surface. Do not countersink. Surface variation in the backing not to exceed 6 mm in 3000 mm or 2 mm in 300 mm. For large format tile where any side is greater than 380 mm (15 in) , surface variation should not exceed 3 mm in 3000 mm and 1,5 mm in 600 mm., Tape joints with 51 mm fibre-mesh tape, fill with a dry-set or latex mortar. Do not sand coated glass mat backer board unless a waterproofing membrane is used after sanding. Apply levelling coat if required. Apply bond coat to mortar bed surface. Use proper notched trowel to ensure adequate bond. Place the tiles firmly into the wet bond coat. Push the tiles back and forth in a direction perpendicular to trowel lines, to collapse the mortar ridges and to help achieve maximum coverage. Ensure proper contact between mortar, tile and substrate by periodically lifting a few tiles to check for acceptable coverage. Use sufficient bond coat to ensure minimum 95% contact in wet areas (it may be necessary to flat back and notch back trowel the tile in order to meet this requirement) . Remove excess mortar from the joint areas so that at least 2/3 of the tile depth is available for grouting. Allow bond coat to cure. Force grout into the joints with a rubber grout float. Make sure all joints are well-compacted and free of voids and gaps. Remove excess grout from the tile surface and clean.

### LIMITATIONS

- Follow manufacturer's recommendations. Maximum tile size is 356 mm x 356 mm x 10 mm, unless recommended by the manufacturer Do not apply directly over concrete or masonry block, unless recommended by the manufacturer. Do not use paper-back or mesh-back mounted tile in locations of extreme moisture unless the manufacturer guarantees that the material is suitable for this type of installation. A surface waterproofing membrane or vapour retarder not to be used behind Foam Core Backer board.

### OTHER CONSIDERATIONS

- Movement joints, spacing and minimum gauge of steel studs as per manufacturer's instructions of coated glass mat backer board.
- Prefabricated movement joints (PMJ) may be used in place of sealant, where shown on drawings where two planes meet.
- All openings and cuts must be treated to ensure waterproof integrity.
- It is recommended to flat back and notch back trowel stone or agglomerated stone
- Refer to Notes For The Professional and 301MJ-2025.
- Latex Portland cement mortars may require 14 – 60 days cure before exposure to water.
- Verify with the manufacturer the correct cure time required. Alternatively, to reduce the curing time required, a rapid set mortar may be more suitable.
- For defective substrates fill tub with water prior to applying caulking to tub sill.

B

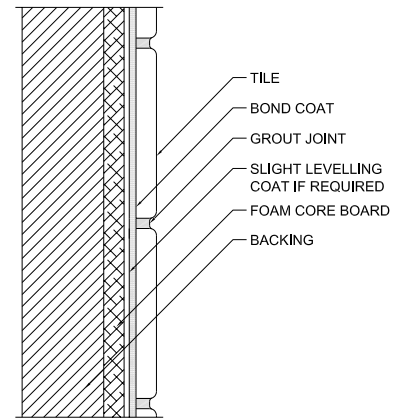

C

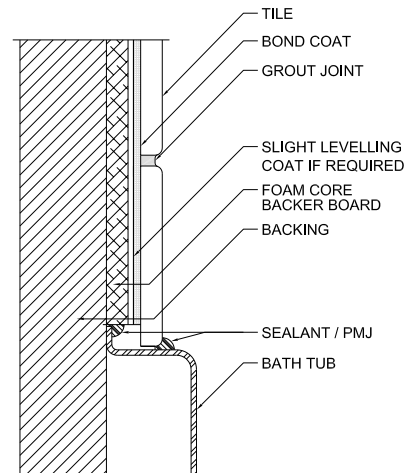

# TILE INSTALLED ON CEMENT MORTAR OVER SOLID BACKING ON INTERIOR/EXTERIOR WALLS

## 307W-2025

### SUITABLE SUBSTRATES

- Concrete or masonry.

### MATERIALS

- **TILE** - Interior: Usually non-vitreous glazed wall tile, but suitable for other types of ceramic tile and mosaic. Consult with manufacturer. Exterior: Use frost resistant materials only
- **METAL LATH** (optional) – 1.4kg/m<sup>2</sup> (ASTM C847)
- **SCRATCH COAT** – 7 mm minimum. See Tile Specification Section Mixes 2.9.2.1.
- **MORTAR BED** – (20 mm+) See Tile Guide Specification Section Mixes 2.9.2.3.
- **MEMBRANE** – ANSI A118.10 All types as recommended by the manufacturer.
- **BOND COAT** – **Interior:** Portland cement slurry on fresh mortar bed or dry-set (minimum acceptable standard ANSI A118.1 or ISO 13007 C1) mortar on mortar bed cured for a minimum of 24 hours. Organic adhesives (Type 1, interior dry surfaces only) (minimum acceptable standard ANSI A136.1 or ISO 13007 D1) on mortar bed cured for minimum of 7 days. Metal lath may be required for surfaces that present bonding problems. **Exterior:** Single or two component liquid latex-Portland cement mortar (minimum acceptable standard ANSI A118.4 of ISO 13007 C2S1).
- **GROUT** – **Interior:** Latex-Portland cement grout (minimum acceptable standard ANSI A118.6 or ISO 13007 CG1) epoxy grout (minimum acceptable standard ANSI A118.3 or ISO 13007 RG). **Exterior:** Latex-Portland cement grout (minimum acceptable standard ANSI A118.6 or ISO 13007 CG1).

### APPLICATION

- Attach metal lath, if required, according to manufacturer's recommendations. Apply scratch coat and cure overnight. Apply mortar bed to required thickness. Finished tolerance of mortar bed not to exceed 6 mm in 3000 mm or 2 mm in 300 mm. For large format tile where any side is greater than 380 mm surface variation should not exceed 3 mm in 3000 mm and 1.5 mm in 600 mm. Apply bond coat to mortar bed surface. Use proper notched trowel to ensure adequate bond. Place the tiles firmly into the wet bond coat. Push the tiles back and forth in a direction perpendicular to trowel lines, to collapse the mortar ridges and to help achieve maximum coverage. Ensure proper contact between mortar, tile and substrate by periodically lifting a few tiles to check for acceptable coverage. Use sufficient bond coat to ensure minimum 95% contact on exterior installations and wet areas (it may be necessary to flat back and notch back trowel the tile in order to meet this requirement) and minimum 80% on interior dry areas. Remove excess mortar from the joint areas so that at least 2/3 of the tile depth is available for grouting. Allow bond coat to cure. Force grout into the joints with a rubber grout float. Make sure all joints are well-compacted and free of voids and gaps. Remove excess grout from the tile surface and clean.

### LIMITATIONS

- Manufacturer's recommendations to be followed.
- Exterior tile installations not to be attempted with a temperature of less than 12°C unless otherwise stated by manufacturer. Do not use paper-back mounted tile or mesh-back tile for exterior use or in locations of extreme moisture should not be used unless the manufacturer guarantees that the material is suitable for this type of installation.

### OTHER CONSIDERATIONS

- Latex additive is recommended for modification of scratch coat, mortar bed and Portland cement bond coat. Follow manufacturer's recommendations. Where job conditions require additional thickness, allow 24 hours cure between coats.
- Tile used on exterior applications must be frost resistant.
- It is recommended to flat back and notch back trowel stone or agglomerated stone
- Refer to Notes For The Professional and 301MJ-2025.
- Waterproofing membrane if required must be specified. (ANSI A118-10) Follow manufacturer's recommendations.
- It is suggested to leave bottom 13 mm of vertical grout joints ungrouted at every 600 mm to allow moisture to escape at the bottom of the wall.
- Latex Portland cement mortars may require 14 – 60 days cure before exposure to water. Verify with the manufacturer the correct cure time required. Alternatively, to reduce the curing time required, a rapid set mortar may be more suitable.
- For external installation proper flashing is required to prevent water ingress between backing wall and the tile

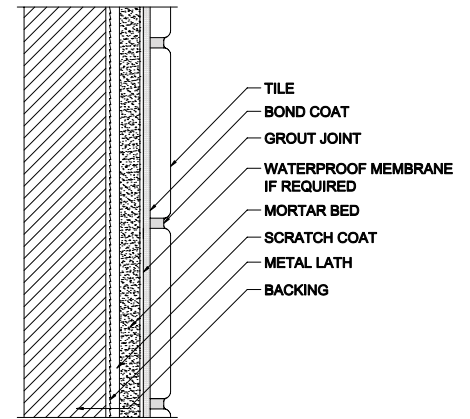

# TILE INSTALLED ON INTERIOR/EXTERIOR WALLS ON CEMENT MORTAR OVER WOOD OR METAL STUDS 308W-2025

## SUITABLE SUBSTRATES

- Metal Lath on wood or metal studs, maximum 406 mm o.c.

## MATERIALS

- TILE – meeting ANSI A137.1, A137.2, A137.3, and for areas of use as recommended by the tile manufacturer
- METAL LATH – 1.4kg/m<sup>2</sup> (ASTM C847).
- SCRATCH COAT – 7mm minimum. See Tile Specification Section Mixes 2.9.2.1.
- MORTAR BED – (20 mm+) See Tile Guide Specification Section Mixes 2.9.2.3.
- VAPOUR RETARDER – Minimum 0.10 mm (6 mils) polyethylene film.
- MEMBRANE – ANSI A118.10 All types as recommended by the manufacturer.
- BOND COAT – **Interior:** Portland cement slurry on fresh mortar bed or dry-set mortar (minimum acceptable standard ANSI A118.1 or ISO 13007 C1) or latex-Portland cement or mortar bed cured for a minimum of 24 hours. Organic adhesive Type 1 (minimum acceptable standard ANSI A136.1 or ISO 13007 D1) (interior dry surfaces only) on mortar bed cured a minimum of 7 days. **Exterior:** Single or two component liquid latex-Portland cement mortar (minimum acceptable standard ANSI A118.4 or ISO 13007 C2S1).
- GROUT – **Interior:** Latex-Portland cement grout (minimum acceptable standard ANSI A118.6 or ISO 13007 CG1), or epoxy grout (minimum acceptable standard ANSI A118.6 or ISO 13007 RG). **Exterior:** Latex-Portland cement grout (minimum acceptable standard ANSI A118.6 or ISO 13007 CG1).

## APPLICATION

- Attach metal lath according to manufacturer's recommendations. Apply scratch coat and cure overnight. Apply mortar bed to required thickness. Finished tolerance of mortar bed not to exceed 6 mm in 3000 mm or 2 mm in 300 mm. For large format tile where any side is greater than 380 mm surface variation should not exceed 3 mm in 3000 mm and 1.5 mm in 600 mm. Apply bond coat to mortar bed surface. Use proper notched trowel to ensure adequate bond. Place the tiles firmly into the wet bond coat. Push the tiles back and forth in a direction perpendicular to trowel lines, to collapse the mortar ridges and to help achieve maximum coverage. Ensure proper contact between mortar, tile and substrate by periodically lifting a few tiles to check for acceptable coverage. Use sufficient bond coat to ensure minimum 95% contact on exterior installations and wet areas (it may be necessary to back-butter the tile in order to meet this requirement) and minimum 80% on interior dry areas. Remove excess mortar from the joint areas so that at least 2/3 of the tile depth is available for grouting. Allow bond coat to cure. Force grout into the joints with a rubber grout float. Make sure all joints are well-compacted and free of voids and gaps. Remove excess grout from the tile surface and clean.

## LIMITATIONS

- Manufacturer's recommendations must be followed.
- Do not use paper-back mounted tile. Mesh-back mounted tile for exterior use or in locations of extreme moisture should not be used unless the manufacturer guarantees that the material is suitable for this type of installation.

## OTHER CONSIDERATIONS

- Latex additive is recommended for modification of scratch coat, mortar bed and Portland cement bond coat. Follow manufacturer's recommendations. If mortar bed must be applied in multiple coats, allow 24 hours between coats.
- It is recommended to back buttering stone or agglomerated stone in wet indoor and exterior installations.
- Tile used on exterior applications must be frost resistant.
- Refer to Notes For The Professional and 301MJ-2019-2021.
- Consultant to specify waterproofing membrane if required.
- Waterproofing membrane if required must be specified. (ANSI A118.10)
- Follow manufacturer's recommendations.

## For Detail B

- Latex Portland cement mortars may require 14 – 60 days cure before exposure to water. Verify with the manufacturer the correct cure time required. Alternatively, to reduce the curing time required, a rapid set mortar may be more suitable. ANSI A118.4 (Latex modified mortar for exterior alternative quick-set) for freeze thaw cycles.
- The difference between interior and exterior installations is the placement of the vapour retarder. Placement to be specified by the consultant.
- It is suggested to leave last 300 mm of vertical grout joints ungrouted at every 600 mm to allow moisture to escape at the bottom of the wall.
- Tile used on exterior applications must be frost resistant.

## INTERIOR

A

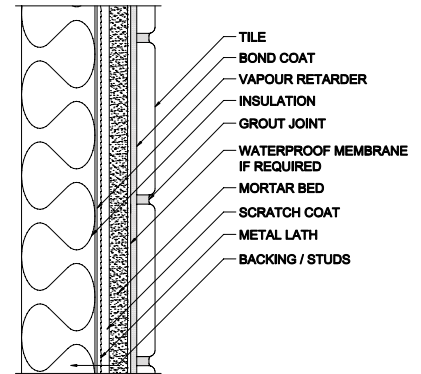

Please refer to page 8.

## EXTERIOR

B

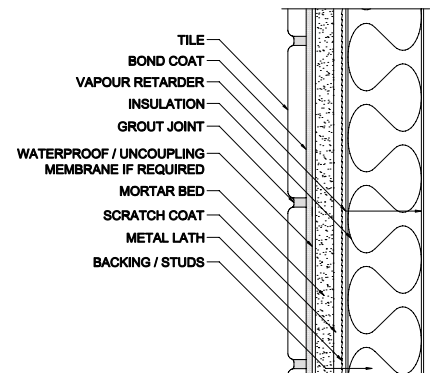

# TILE OVER MORTAR BED WITH CLEAVAGE MEMBRANE INTERIOR ONLY 309F-2025

## SUITABLE SUBSTRATES

- Floor systems over which the tile will be installed shall be in conformance with the National Building Code 2015 and applicable local building codes taking into consideration anticipated live and dead loads.

## MATERIALS

- TILE – meeting ANSI A137.1, A137.2, A137.3, and for areas of use as recommended by the tile manufacturer
- CLEAVAGE MEMBRANE – 0.10 mm (6 mils) polyethylene (optional 15 lb felt).
- REINFORCING MESH – 51 mm x 51 mm x 1.6 mm – welded wire/fabric (galvanized square wire mesh) (ASTM A82, ASTM A185).
- BOND COAT – Portland cement slurry on fresh mortar bed or dry set (minimum acceptable standard ANSI A118.1 or ISC 13007 C1), latex-Portland cement mortar (minimum acceptable standard ANSI A118.4 or ISO 13007 C2) or modified epoxy emulsion mortars (minimum acceptable standard ANSI A118.3 or ISO 13007 R1) over mortar bed, cured for minimum of 24 hours. 100% solid epoxy mortar on mortar bed, cured for a minimum of 7 days.
- GROUT – Portland cement, latex-Portland cement grout (minimum acceptable standard ANSI A118.6 or ISO 13007 CG1) or epoxy grout (minimum acceptable standard ANSI A118.3 or ISO 13007 RG).

## APPLICATION

- Maintain a minimum of 16 mm of mortar under wire reinforcement. Apply mortar bed (see Tile Guide Specification Section Mixes 2.9.2.5) to required thickness. Finished tolerance of mortar bed not to exceed 6 mm in 3000 mm or 2 mm in 300 mm. For large format tile where any side is greater than 380 mm surface variation should not exceed 3 mm in 3000 mm and 1.5 mm in 600 mm. For tile with any edge longer than 380 mm use sufficient bond coat to ensure minimum 95% contact, with the corners and edges fully supported. Apply bond coat to mortar bed surface. Use proper notched trowel to ensure adequate bond. Place the tiles firmly into the wet bond coat. Push the tiles back and forth in a direction perpendicular to trowel lines, to collapse the mortar ridges and to help achieve maximum coverage. Ensure proper contact between mortar, tile and substrate by periodically lifting a few tiles to check for acceptable coverage. Use sufficient bond coat to ensure minimum 95% contact on exterior installations and wet areas (it may be necessary to back-butter the tile in order to meet this requirement) and minimum 80% on interior dry areas. Remove excess mortar from the joint areas so that at least 2/3 of the tile depth is available for grouting. Allow bond coat to cure. Force grout into the joints with a rubber grout float. Make sure all joints are well-compacted and free of voids and gaps. Remove excess grout from the tile surface and clean.

## LIMITATIONS

- Manufacturer's recommendations must be followed.
- The thickness of the mortar bed should be 32 mm to 51 mm minimum unless otherwise stated by manufacturer.

## OTHER CONSIDERATIONS

- Latex additive used in place of water is recommended for Portland cement bond coat, and may be used in modification of mortar bed.
- Where required for chemical resistance, 100% solids epoxy setting material and/or grout should be used.
- Refer to Notes for the Professional and 301MJ-2019-2021.
- Refer to notes on Crack Isolation Membranes and 311F-2019-2021 Detail C.

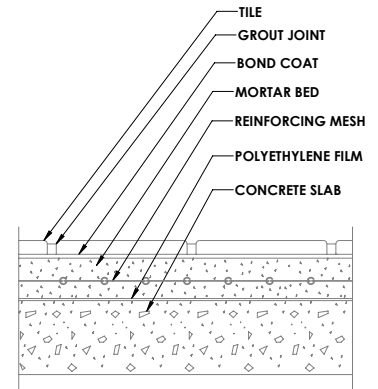

# TILE INSTALLED ON INTERIOR/EXTERIOR CEMENT MORTAR BED ON CONCRETE SLAB

## 310F-2025

### DETAIL A

#### SUITABLE SUBSTRATES

- Floor systems over which the tile will be installed shall be in conformance with the Canadian National Building Code 2020 and applicable local building codes taking into consideration anticipated live and dead loads.

#### MATERIALS

- **TILE** – meeting ANSI A137.1, A137.2, A137.3, and for areas of use as recommended by the tile manufacturer
- **MEMBRANE** – ANSI A118.10 All types as recommended by the manufacturer.
- **BOND COAT** – **Interior:** Portland cement slurry on concrete slab and on fresh mortar bed. Dry-set mortar (minimum acceptable standard ANSI A118.1 or ISO 13007 C1), latex-Portland cement mortar (minimum acceptable standard ANSI A118.4 or ISO 13007 C2S1), or modified epoxy emulsion mortars (minimum acceptable standard ANSI A118.3 or ISO 13007 R1), over mortar bed, cured for minimum of 24 hours. 100% solids epoxy mortar on mortar bed, cured a minimum of 7 days. **Exterior:** Single or two component liquid latex-Portland cement mortar (minimum acceptable standard ANSI A118.4 or ISO 13007 C2S1).
- **GROUT** – **Interior:** Portland cement, latex-Portland cement (minimum acceptable standard ANSI A118.6 or ISO 13007 CG1) or epoxy grouts (minimum acceptable standard ANSI A118.3 or ISO 13007 RG). **Exterior:** Latex-Portland cement.

#### APPLICATION

- Apply mortar bed (see Tile Guide Specification Section Mixes 2.9.2.5) to required thickness over fresh slurry bond coat (see Tile Guide Specification Section Mixes 2.9.2.2). Finished tolerance of mortar bed not to exceed 6 mm in 3000 mm or 2 mm in 300 mm. For large format tile where any side is greater than 380 mm surface variation should not exceed 3 mm in 3000 mm and 1.5 mm in 600 mm. For tile with any edge longer than 380 mm use sufficient bond coat to ensure minimum 95% contact, with the corners and edges fully supported. Apply bond coat to mortar bed surface. Use proper notched trowel to ensure adequate bond. Place the tiles firmly into the wet bond coat. Push the tiles back and forth in a direction perpendicular to trowel lines, to collapse the mortar ridges and to help achieve maximum coverage. Ensure proper contact between mortar, tile and substrate by periodically lifting a few tiles to check for acceptable coverage. Use sufficient bond coat to ensure minimum 95% contact on exterior installations and wet areas (it may be necessary to back-butter the tile in order to meet this requirement) and minimum 80% on interior dry areas. Remove excess mortar from the joint areas so that at least 2/3 of the tile depth is available for grouting. Allow bond coat to cure. Force grout into the joints with a rubber grout float. Make sure all joints are well-compacted and free of voids and gaps. Remove excess grout from the tile surface and clean.

#### LIMITATIONS

- Manufacturer's recommendations must be followed.
- The thickness of the mortar bed should be 32 mm minimum interior and 38 mm minimum exterior.
- Use method 309F-2025 for precast floor systems, post tensioned concrete floor systems and other floors subject to movement or deflection.

#### OTHER CONSIDERATIONS

- Latex additive is recommended for Portland cement bond coat, and may be used in modification of mortar bed. Follow manufacturer's recommendations.
- Tile used on exterior applications must be frost resistant.
- For industrial and chemical resistant floors use the appropriate setting and grouting materials as per manufacturer's recommendations. Must meet extra heavy duty rating. See page 31.
- Refer to Notes For The Professional and 301MJ-2019-2021.
- If installation is over an occupied living space, use Detail 325ED-2019-2021 Detail A.
- Waterproofing membrane if required must be specified. (ANSI A118.10) Follow manufacturer's recommendations.
- For moderate commercial to industrial applications for tile that are larger than 300 mm x 300 mm, a minimum of 95% coverage must be achieved.
- Membrane – follow manufacturer's recommendations for appropriate mortars.

Continued

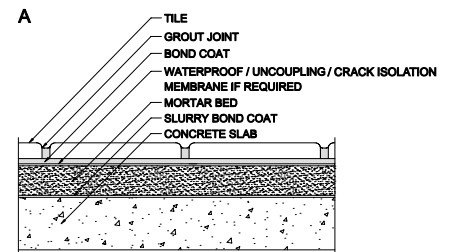

# TILE INSTALLED ON INTERIOR/EXTERIOR CEMENT MORTAR BED ON CONCRETE SLAB

## 310F-2025

### DETAIL B - CHEMICAL RESISTANCE

#### SUITABLE SUBSTRATES

- Interior only concrete slab where chemical resistance is desired. Suitable for food plants, dairies, breweries and commercial kitchens. Concrete floor systems, over which the tile will be installed shall be in conformance with the Canadian National Building Code 2020 and applicable local building codes taking into consideration anticipated live and dead loads.

#### MATERIALS

- TILE – meeting ANSI A137.1, A137.2, A137.3, and for areas of use as recommended by the tile manufacturer
- BOND COAT – **Interior:** Portland cement slurry on concrete slab and on fresh mortar bed. 100% solids epoxy mortar (minimum acceptable standard ANSI A118.3 or ISO 13007 R1) on chemical resistant membrane on mortar bed, cured a minimum of 7 days.
- GROUT – 100% solids epoxy (minimum acceptable standard ANSI A118.3 or ISO 13007 RG).

#### APPLICATION

- Apply mortar bed (see Tile Guide Specification Section 2.9.2.5) to required thickness over fresh slurry bond coat (see Tile Guide Specification Section 2.9.2.2). Finished tolerance of mortar bed not to exceed 6 mm in 3000 mm or 2 mm in 300 mm. For large format tile where any side is greater than 380 mm surface variation should not exceed 3 mm in 3000 mm and 1.5 mm in 600 mm. For tile with any edge longer than 380 mm use sufficient bond coat to ensure minimum 95% contact, with the corners and edges fully supported. Apply chemical resistant membrane to mortar bed as recommended by manufacturer. Apply bond coat to mortar bed surface. Use proper notched trowel to ensure adequate bond. Place the tiles firmly into the wet bond coat. Push the tiles back and forth in a direction perpendicular to trowel lines, to collapse the mortar ridges and to help achieve maximum coverage. Ensure proper contact between mortar, tile and substrate by periodically lifting a few tiles to check for acceptable coverage. Use sufficient bond coat to ensure minimum 95% contact on exterior installations and wet areas (it may be necessary to back-butter the tile in order to meet this requirement) and minimum 80% on interior dry areas. Remove excess mortar from the joint areas so that at least 2/3 of the tile depth is available for grouting. Allow bond coat to cure. Force grout into the joints with a rubber grout float. Make sure all joints are well-compacted and free of voids and gaps. Remove excess grout from the tile surface and clean.

#### LIMITATIONS

- Thickness of the mortar bed should be 32 mm minimum.
- Epoxy grout should not be used where subjected to heat surpassing 100°C or as per manufacturer's recommendations. Use furan resin grout for areas subjected to excessive heat.

#### OTHER CONSIDERATIONS

- Refer to Notes For The Professional and 301MJ-2019-2021.
- Movement joints must be chemical resistant sealant or prefabricated movement joints.
- Waterproofing membrane if required must be specified. (ANSI A118.10) Follow manufacturer's recommendations.
- Uncoupling Membrane – follow manufacturer's recommendations. Please see page 31 for more information.
- For moderate commercial to industrial applications for tile that are larger than 300 mm x 300 mm, a minimum of 95% coverage must be achieved.

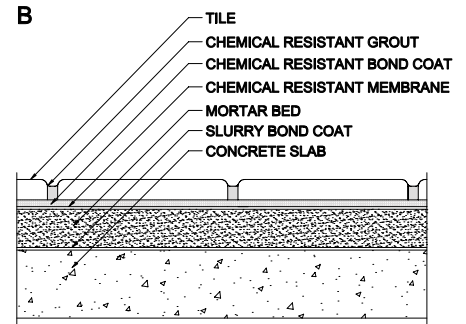

# ★ TILE INSTALLED ON INTERIOR FLOWABLE HYDRAULIC CEMENT UNDERLAYMENT/SELF-LEVELING UNDERLAYMENT ON CONCRETE SLAB 310F-2025

## DETAIL B2 - CHEMICAL RESISTANCE

### SUITABLE SUBSTRATES

- Interior only concrete slab where chemical resistance is desired. Suitable for food plants, dairies, breweries and commercial kitchens. Concrete floor systems, over which the tile will be installed shall be in conformance with the Canadian National Building Code 2020 and applicable local building codes taking into consideration anticipated live and dead loads.

### MATERIALS

- TILE – meeting ANSI A137.1, A137.2, A137.3, and for areas of use as recommended by the tile manufacturer
- Optional - MOISTURE MITIGATION MEMBRANE - Meeting ASTM F3010 when moisture vapor emission levels exceed chemical resistant membrane limitations. Place directly on prepared concrete
- PRIMER - All types as recommended by the manufacturer
- FLOWABLE HYDRAULIC CEMENT UNDERLAYMENT/SELF-LEVELING UNDERLAYMENT – Interior only. (minimum acceptable standard ANSI A118.16)
- BOND COAT –100% solids epoxy mortar (minimum acceptable standard ANSI A118.3 or ISO 13007 R1) on chemical resistant membrane on FHCU/SLU, cured a minimum of 24hrs.
- GROUT – 100% solids epoxy (minimum acceptable standard ANSI A118.3 or ISO 13007 RG).

### APPLICATION

- Apply appropriate primer to properly prepared substrate. Place FHCU/SLU to required thickness according to manufacturer's limitations per lift.
- Finished tolerance of mortar bed not to exceed 6 mm in 3000 mm or 2 mm in 300 mm. For large format tile where any side is greater than 380 mm surface variation should not exceed 3 mm in 3000 mm and 1.5 mm in 600 mm. For tile with any edge longer than 380 mm use sufficient bond coat to ensure minimum 95% contact, with the corners and edges fully supported. Apply chemical resistant membrane to mortar bed as recommended by manufacturer. Apply bond coat to mortar bed surface. Use proper notched trowel to ensure adequate bond. Place the tiles firmly into the wet bond coat. Push the tiles back and forth in a direction perpendicular to trowel lines, to collapse the mortar ridges and to help achieve maximum coverage. Ensure proper contact between mortar, tile and substrate by periodically lifting a few tiles to check for acceptable coverage. Use sufficient bond coat to ensure minimum 95% contact on exterior installations and wet areas (it may be necessary to back-butter the tile in order to meet this requirement) and minimum 80% on interior dry areas. Remove excess mortar from the joint areas so that at least 2/3 of the tile depth is available for grouting. Allow bond coat to cure. Force grout into the joints with a rubber grout float. Make sure all joints are well-compacted and free of voids and gaps. Remove excess grout from the tile surface and clean.

### LIMITATIONS

- Thickness of the FHCU/SLU - featheredge to 38mm per lift.
- Epoxy grout should not be used where subjected to heat surpassing 100°C or as per manufacturer's recommendations. Use furan resin grout for areas subjected to excessive heat.

### OTHER CONSIDERATIONS

- Refer to Notes For The Professional and 301MJ-2019-2021.
- Movement joints must be chemical resistant sealant or prefabricated movement joints.
- Waterproofing membrane if required must be specified. (ANSI A118.10) Follow manufacturer's recommendations.
- Uncoupling Membrane – follow manufacturer's recommendations. Please see page 31 for more information.
- For moderate commercial to industrial applications for tile that are larger than 300 mm x 300 mm, a minimum of 95% coverage must be achieved.

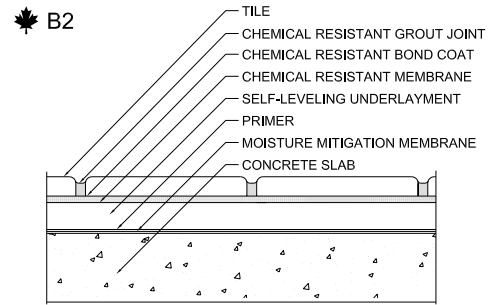

★ **TILE INSTALLED ON INTERIOR FLOWABLE HYDRAULIC CEMENT UNDERLAYMENT/SELF-LEVELING UNDERLAYMENT ON CONCRETE SLAB**  
**310F-2025**

**DETAIL C – Interior Only**

**SUITABLE SUBSTRATES**

- Floor systems over which the tile will be installed shall be in conformance with the Canadian National Building Code 2020 and applicable local building codes taking into consideration anticipated live and dead loads.

**MATERIALS**

- **TILE** – meeting ANSI A137.1, A137.2, A137.3, and for areas of use as recommended by the tile manufacturer
- **PRIMER** - All types as recommended by the manufacturer
- **FLOWABLE HYDRAULIC CEMENT UNDERLAYMENT/SELF-LEVELING UNDERLAYMENT** – Interior only. (minimum acceptable standard ANSI A118.16)
- **BOND COAT** – Interior: Portland cement slurry on concrete slab and on fresh mortar bed. Dry-set mortar (minimum acceptable standard ANSI A118.1 or ISO 13007 C1), latex-Portland cement mortar (minimum acceptable standard ANSI A118.4 or ISO 13007 C2S1), or modified epoxy emulsion mortars (minimum acceptable standard ANSI A118.3 or ISO 13007 R1), over FHCU/SLU, cured for minimum of 4 hours for rapid hardening; 24 hrs. for standard setting.
- **GROUT** – Interior: Portland cement, latex-Portland cement (minimum acceptable standard ANSI A118.6 or ISO 13007 CG1) or epoxy grouts (minimum acceptable standard ANSI A118.3 or ISO 13007 RG).

**APPLICATION**

- Apply appropriate primer to properly prepared substrate. Place FHCU/SLU to required thickness according to manufacturer's limitations per lift (typically featheredge to 38mm per lift). For large format tile where any side is greater than 380 mm surface variation should not exceed 3 mm in 3000 mm and 1.5 mm in 600 mm. For tile with any edge longer than 380 mm use sufficient bond coat to ensure minimum 95% contact, with the corners and edges fully supported. Use proper notched trowel to ensure adequate bond. Place the tiles firmly into the wet bond coat. Push the tiles back and forth in a direction perpendicular to trowel lines, to collapse the mortar ridges and to help achieve maximum coverage. Ensure proper contact between mortar, tile and substrate by periodically lifting a few tiles to check for acceptable coverage. Use sufficient bond coat to ensure minimum 80% coverage. Remove excess mortar from the joint areas so that at least 2/3 of the tile depth is available for grouting. Allow bond coat to cure. Force grout into the joints with a rubber grout float. Make sure all joints are well-compacted and free of voids and gaps. Remove excess grout from the tile surface and clean.

**LIMITATIONS**

- Manufacturer's recommendations must be followed.
- Ambient, substrate and mixture temperatures are to be at least 10°C. Chill mixing water in higher temperatures as needed. Provide ventilation to avoid substrate condensation and dew point to allow FHCU/SLU to dry properly.
- Provide adequate movement joints for post tensioned concrete floor systems and other floors subject to movement or deflection.

**OTHER CONSIDERATIONS**

- Unless clearly specified, substrate will be flattened to meet ANSI flatness requirements. If elevation is to be level, surveying and details will be required.
- For industrial and chemical resistant floors use the appropriate setting and grouting materials as per manufacturer's recommendations. Must meet extra heavy duty rating. See page 31.
- Refer to Notes For The Professional and 301MJ-2019-2021.
- Waterproofing membrane if required must be specified. (ANSI A118.10) Follow manufacturer's recommendations.
- For moderate commercial to industrial applications for tile that are larger than 300 mm x 300 mm, a minimum of 95% coverage must be achieved.
- Membrane – follow manufacturer's recommendations for appropriate mortars.
- Include a moisture mitigation membrane meeting ASTM C3010 or other appropriate membrane under FHCU/SLU when concrete RH exceeds tile or other assembly material's limitations.

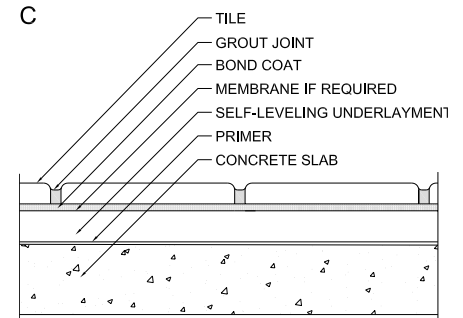

# TILE BONDED TO CONCRETE SLAB - THIN-SET METHOD

## 311F-2025

### DETAIL A INTERIOR/EXTERIOR

#### SUITABLE SUBSTRATES

- Floor systems over which the tile will be installed shall be in conformance with the Canadian National Building Code 2020 and applicable local building codes taking into consideration anticipated live and dead loads.

#### MATERIALS

- TILE** – meeting ANSI A137.1, A137.2, A137.3, and for areas of use as recommended by the tile manufacturer
- BOND COAT** – **Interior:** Dry-set mortar (minimum acceptable standard ANSI A118.1 or ISO 13007 C1), latex-Portland cement mortar (minimum acceptable standard ANSI A118.4 or ISO 13007 C2S1), modified epoxy emulsion mortars, 100% solids epoxy mortar, epoxy adhesive (minimum acceptable standard ANSI A118.3 or ISO 13007 R1), or organic adhesives (minimum acceptable standard ANSI A118.3 or ISO 13007 R1). **Exterior:** Single or two component liquid latex-Portland cement mortar (minimum acceptable standard ANSI A118.4 or ISO 13007 C2S1).
- GROUT** – **Interior:** Portland cement, latex-Portland cement (minimum acceptable standard ANSI A118.6 or ISO 13007 CG1), or epoxy grouts (minimum acceptable standard ANSI A118.3 or ISO 13007 RG). **Exterior:** Latex-Portland cement (minimum acceptable standard ANSI A118.6 or ISO 13007 CG1).

#### APPLICATION

- Maximum variation of slab should not exceed 6 mm in 3000 mm or 2 mm in 300 mm. For large format tile where any side is greater than 380 mm, surface variation should not exceed 3 mm in 3000 mm and 1.5 mm in 600 mm. For tile with any edge longer than 380 mm use sufficient bond coat to ensure minimum 95% contact, with the corners and edges fully supported. Apply bond coat to mortar bed surface. Use proper notched trowel to ensure adequate bond. With pressure, apply a coat of mortar by using the trowel's flat side to key the mortar into the substrate. Apply additional mortar, combing it in a single direction parallel to the tile's shortest dimension, with the trowel's notched side. Place the tiles firmly into the wet bond coat. Push the tiles back and forth in a direction perpendicular to trowel lines, to collapse the mortar ridges and to help achieve maximum coverage. Ensure proper contact between mortar, tile and substrate by periodically lifting a few tiles to check for acceptable coverage. Use sufficient bond coat to ensure to minimum 95% contact for exterior installations, commercial floor and in wet areas (it may be necessary to back-butter the tile in order to meet this requirement) and minimum 80% on interior dry areas. Remove excess mortar from the joint areas so that at least 2/3 of the tile depth is available for grouting. Allow bond coat to cure. Force grout into the joints with a rubber grout float. Make sure all joints are well-compacted and free of voids and gaps. Remove excess grout from the tile surface and clean.

#### LIMITATIONS

- Manufacturer's recommendations must be followed.
- Provide positive drainage below exterior slabs; use latex-Portland cement mortars on exterior slabs. Use of epoxy mortars and grouts is recommended for interior surfaces only or where improved chemical resistance is required.
- Use method 309F-2019-2021 or crack isolation/uncoupling membrane if recommended by the manufacturer for precast floor systems, post tensioned concrete floor systems and other floors subject to movement or deflection.
- Not a roof assembly. (For roof assembly see Detail 325F-2019-2021 Detail A)

#### OTHER CONSIDERATIONS

- For exterior installations, use a suitable latex-Portland cement mortar. Back-buttering of the tile is required to achieve 95% contact.
- Tile used in exterior applications must be frost resistant.
- Refer to Notes For The Professional and 301MJ-2019-2021.
- Waterproofing membrane if required must be specified. (ANSI A118.10) Follow manufacturer's recommendations.
- For exterior use concrete slab must be sloped to provide positive surface drainage and adequate drainage below slab must be provided.
- Uncoupling Membrane – follow manufacturer's recommendations for appropriate mortars: membrane must achieve 0.3 N/mm<sup>2</sup> (50 PSI or greater) shear bond strength after 7 days per the test method in ANSI A118.12 section 5.1.3. ANSI A118.20 coming 2025
- Bond Coat to Uncoupling membrane- Dry-set mortar (minimum acceptable standard ANSI A118.1 or ISO C1, Latex Portland cement mortar (minimal acceptable standard ANSI A118.4 or ISO C2S1) or Improved Modified Dry-set cement mortar (minimal acceptable standard ANSI A118.15 or ISO C2 F and/or T, and/or S1, modified epoxy emulsion mortars or 100% solids epoxy mortars (minimum acceptable standard ANSI A118.3 or ISO RG).

Continued

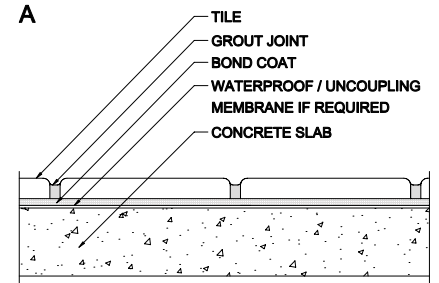

# TILE BONDED TO CONCRETE SLAB - THIN-SET METHOD 311F-2025

## DETAIL B – EPOXY METHOD INTERIOR ONLY

### SUITABLE SUBSTRATES

- Interior only concrete slab where chemical resistance is desired. Suitable for food plants, dairies, breweries and commercial kitchens. Concrete floor systems, over which the tile will be installed shall be in conformance with the
- Canadian National Building Code 2020 and applicable local building codes taking into consideration anticipated live and dead loads.

### MATERIALS

- TILE – meeting ANSI A137.1, A137.2, A137.3, and for areas of use as recommended by the tile manufacturer
- BOND COAT – 100% solids epoxy mortar (minimum acceptable standard ANSI A118.3 or ISO 13007 R1).
- GROUT – 100% solids epoxy (minimum acceptable standard ANSI A118.3 or ISO 13007 RG).

### APPLICATION

- Maximum variation of slab should not exceed 6 mm in 3000 mm or 2 mm in 300 mm. For large format tile any side is greater than 380 mm, surface variation should not exceed 3 mm in 3000 mm and 1.5 mm in 600 mm. For tile with any edge longer than 380 mm use sufficient bond coat to ensure minimum 95% contact, with the corners and edges fully supported. Use proper notched trowel to ensure adequate bond. With pressure, apply a coat of mortar by using the trowel's flat side to key the mortar into the substrate. Apply additional mortar, combing it in a single direction parallel to the tile's shortest dimension, with the trowel's notched side. Place the tiles firmly into the wet bond coat. Push the tiles back and forth in a direction perpendicular to trowel lines, to collapse the mortar ridges and to help achieve maximum coverage. Ensure proper contact between mortar, tile and substrate by periodically lifting a few tiles to check for acceptable coverage. Use sufficient bond coat to ensure 95% contact (it may be necessary to back-butter tile to achieve this requirement). Remove excess mortar from the joint areas so that at least 2/3 of the tile depth is available for grouting. Allow bond coat and grout to cure as recommended by the manufacturer for the type of environment and exposure anticipated. Force grout into the joints with a rubber grout float. Make sure all joints are well-compacted and free of voids and gaps. Remove excess grout from the tile surface and clean.

### LIMITATIONS

- Epoxy grout should not be used where subjected to heat surpassing 100°C or as per manufacturer's recommendations. Use furan resin grout for areas subjected to excessive heat.

### OTHER CONSIDERATIONS

- Refer to Notes For The Professional and 301MJ-2019-2021.
- Movement joints must be chemical resistant sealant or prefabricated movement joints.
- For industrial and chemical resistant floors, use the appropriate chemical resistant membrane, setting material and grouts in place of materials mentioned above. If specified, system must meet extra heavy duty rating. Follow manufacturer's instructions carefully.

Continued

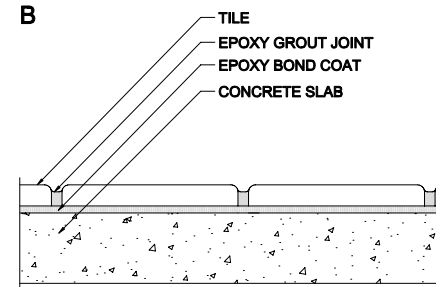

# TILE BONDED TO CONCRETE SLAB - THIN-SET METHOD

## 311F-2025

### DETAIL C – CRACK CONCRETE INTERIOR/EXTERIOR – FULL COVERAGE

#### SUITABLE SUBSTRATES

- Floor systems over which the tile will be installed shall be in conformance with the Canadian National Building Code 2020 and applicable local building codes taking into consideration anticipated live and dead loads.

#### MATERIALS

- TILE** – meeting ANSI A137.1, A137.2, A137.3, and for areas of use as recommended by the tile manufacturer
- BOND COAT** – **Interior:** Dry-set mortar (minimum acceptable standard ANSI A118.1 or ISO 13007 C1), latex-Portland cement mortar (minimum acceptable standard ANSI A118.4 or ISO 13007 C2S1), modified epoxy emulsion mortars, 100% solids epoxy mortar (minimum acceptable standard ANSI A118.3 or ISO 13007 R1).  
**Exterior:** Single or two component liquid latex cement mortar (minimum acceptable standard ANSI A118.4 or ISO 13007 C2S1).
- GROUT** – **Interior:** Portland cement, latex-Portland cement (minimum acceptable standard ANSI A118.6 or ISO 13007 CG1), or epoxy grouts (minimum acceptable standard ANSI A118.3 or ISO 13007 RG). **Exterior:** Latex-Portland cement (minimum acceptable standard ANSI A118.6 or ISO 13007 CG1).
- Crack Isolation membrane conforming to ANSI A118.12.
- Consult manufacturer for product compatibility.
- Membrane Bond Coat as required by manufacturers recommendations.

#### APPLICATION

- Maximum variation of slab should not exceed 6 mm in 3000 mm or 2 mm in 300 mm. For large format tile where any side is greater than 380 mm, surface variation should not exceed 3 mm in 3000 mm and 1.5 mm in 600 mm. For tile with any edge longer than 380 mm use sufficient bond coat to ensure minimum 95% contact, with the corners and edges fully supported. Apply crack isolation membrane or uncoupling membrane as per manufacturer's recommendations. Apply movement joint if required on one or both sides of the tile bringing the existing crack. Use proper notched trowel to ensure adequate bond. With pressure, apply a coat of mortar by using the trowel's flat side to key the mortar into the substrate. Apply additional mortar, combing it in a single direction parallel to the tile's shortest dimension, with the trowel's notched side. Place the tiles firmly into the wet bond coat. Push the tiles back and forth in a direction perpendicular to trowel lines, to collapse the mortar ridges and to help achieve maximum coverage. Ensure proper contact between mortar, tile and substrate by periodically lifting a few tiles to check for acceptable coverage. Use sufficient bond coat to ensure minimum 95% contact on exterior installations and wet areas (it may be necessary to back-butter the tile in order to meet this requirement) and minimum 80% on interior dry areas. Remove excess mortar from the joint areas so that at least 2/3 of the tile depth is available for grouting. Allow bond coat and grout to cure as recommended by the manufacturer for the type of environment and exposure anticipated. Allow bond coat to cure. Force grout into the joints with a rubber grout float. Make sure all joints are well-compacted and free of voids and gaps. Remove excess grout from the tile surface and clean.

#### LIMITATIONS

- Manufacturers' recommendations must be followed.
- Verify with manufacturer if product is sensitive to high PH levels in concrete.
- Verify with manufacturer if product is suitable for exterior installations and follow manufacturer's recommendations for suitable bond coat materials.

#### OTHER CONSIDERATIONS

- Not to be used over expansion joints, cold joints or structural joints.
- Tile used in exterior installations must be frost resistant.
- Refer to Notes For The Professional and 301MJ-2019-2021.
- For exterior use, concrete slab must be sloped to provide positive surface drainage and adequate drainage below slab must be provided.
- Some manufacturers recognize the use of their products for partial coverage, over existing cracks. Follow manufacturer's recommendations/guidelines.
- Uncoupling Membrane – follow manufacturer's recommendations. Please see page 31 for more information.

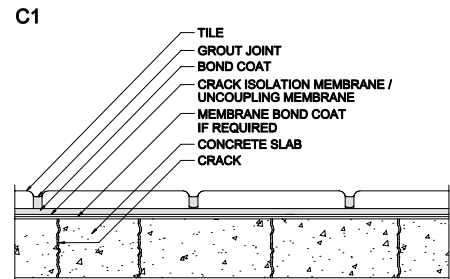
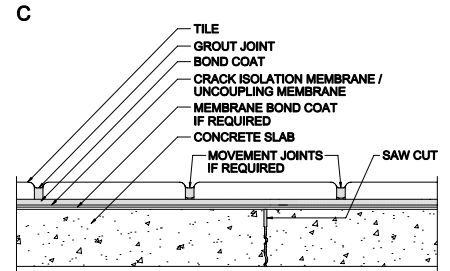

# TILE BONDED TO CONCRETE SLAB - THIN-SET METHOD 311F-2024

## DETAIL D – UNCOUPLING OVER GREEN/YOUNG CONCRETE

### SUITABLE SUBSTRATES

- Concrete floor systems over which the tile will be installed shall be in conformance with the Canadian National Building Code 2020 and applicable local building codes taking into consideration anticipated live and dead loads.

### MATERIALS

- TILE – meeting ANSI A137.1, A137.2, A137.3, and for areas of use as recommended by the tile manufacturer
- BOND COAT – Follow uncoupling membrane manufacturer's directions.
- Uncoupling Membrane – ANSI A118.20 Follow manufacturer's recommendations.
- GROUT – **Interior:** Portland cement, latex-Portland cement (minimum acceptable standard ANSI A118.6 or ISO CG1), or epoxy grouts (minimum acceptable standard ANSI A118.3 or ISO RG). **Exterior:** Latex-Portland cement (minimum acceptable standard ANSI A118.6 or ISO CG1).

### APPLICATION

- Over green/young concrete cured a minimum of 48 hours and suitable to support tile installation traffic as determined by the project design professional project design professional, construction manager or general contractor.
- Maximum variation of slab should not exceed 6 mm in 3000 mm or 2 mm in 300 mm. For large format tile where any side is greater than 380 mm, surface variation should not exceed 3 mm in 3000 mm and 1.5 mm in 600 mm. For tile with any edge longer than 380 mm use sufficient bond coat to ensure minimum 95% contact, with the corners and edges fully supported. Apply crack isolation membrane or uncoupling membrane as per manufacturer's recommendations. Apply movement joint if required on one or both sides of the tile bringing the existing crack. Use proper notched trowel to ensure adequate bond. With pressure, apply a coat of mortar by using the trowel's flat side to key the mortar into the substrate. Apply additional mortar, combing it in a single direction parallel to the tile's shortest dimension, with the trowel's notched side. Place the tiles firmly into the wet bond coat. Push the tiles back and forth in a direction perpendicular to trowel lines, to collapse the mortar ridges and to help achieve maximum coverage. Ensure proper contact between mortar, tile and substrate by periodically lifting a few tiles to check for acceptable coverage. Use sufficient bond coat to ensure minimum 95% contact on exterior installations and wet areas (it may be necessary to back-butter the tile in order to meet this requirement) and minimum 80% on interior dry areas. Remove excess mortar from the joint areas so that at least 2/3 of the tile depth is available for grouting. Allow bond coat and grout to cure as recommended by the manufacturer for the type of environment and exposure anticipated. Allow bond coat to cure. Force grout into the joints with a rubber grout float. Make sure all joints are well-compacted and free of voids and gaps. Remove excess grout from the tile surface and clean.

### LIMITATIONS

- Manufacturers' recommendations must be followed.
- Verify with manufacturer if product is suitable for exterior installations and follow manufacturer's recommendations for suitable bond coat materials.

### OTHER CONSIDERATIONS

- Tile used in exterior installations must be frost resistant.
- Refer to Notes For The Professional and 301MJ-2019-2021.
- For exterior use, concrete slab must be sloped to provide positive surface drainage and adequate drainage below slab must be provided.

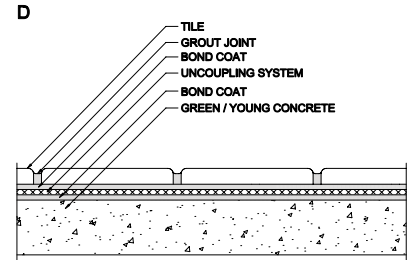

# ★ TILE BONDED TO CONCRETE SLAB - THIN-SET METHOD 312F-2025

## DETAIL A INTERIOR

### SUITABLE SUBSTRATES

- Concrete floor systems over which the tile will be installed shall be in conformance with the Canadian National Building Code 2020 and applicable local building codes taking into consideration anticipated live and dead loads.

### MATERIALS

- TILE – meeting ANSI A137.1, A137.2, A137.3, and for areas of use as recommended by the tile manufacturer
- BOND COAT – Interior: Dry-set mortar (minimum acceptable standard ANSI A118.1 or ISO 13007 C1), latex-Portland cement mortar (minimum acceptable standard ANSI A118.4 or ISO 13007 C2S1), modified epoxy emulsion mortars, 100% solids epoxy mortar, epoxy adhesive (minimum acceptable standard ANSI A118.3 or ISO 13007 R1),
- Uncoupling (ANSI A118.20) /Crack Isolation membrane (ANSI A118.12): follow manufacturers recommendations
- GROUT –Portland cement, latex-Portland cement (minimum acceptable standard A118.6 or ISO 13007 CG1), or epoxy grouts (minimum acceptable standard ANSI A118.3 or ISO 13007 RG). Exterior: Latex-Portland cement (minimum acceptable standard ANSI A118.6 or ISO 13007 CG1).

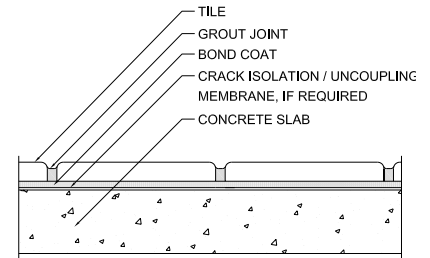

### APPLICATION

- For above ground structural slabs and other floors subject to movement or deflection where thin bed tile installation is desired. Maximum variation of slab should not exceed 6 mm in 3000 mm or 2 mm in 300 mm. For large format tile where any side is greater than 380 mm, surface variation should not exceed 3 mm in 3000 mm and 1.5 mm in 600 mm. For tile with any edge longer than 380 mm use sufficient bond coat to ensure minimum 95% contact, with the corners and edges fully supported. Apply bond coat to mortar bed surface. Use proper notched trowel to ensure adequate bond. With pressure, apply a coat of mortar by using the trowel's flat side to key the mortar into the substrate. Apply additional mortar, combing it in a single direction parallel to the tile's shortest dimension, with the trowel's notched side. Place the tiles firmly into the wet bond coat. Push the tiles back and forth in a direction perpendicular to trowel lines, to collapse the mortar ridges and to help achieve maximum coverage. Ensure proper contact between mortar, tile and substrate by periodically lifting a few tiles to check for acceptable coverage. (it may be necessary to flat back trowel or notch back trowel the tile in order to meet this requirement) and minimum 80% on interior dry areas. Remove excess mortar from the joint areas so that at least 2/3 of the tile depth is available for grouting. Allow bond coat to cure. Force grout into the joints with a rubber grout float. Make sure all joints are well-compacted and free of voids and gaps. Remove excess grout from the tile surface and clean.

### LIMITATIONS

- Manufacturer's recommendations must be followed.
- Use crack isolation/uncoupling membrane if recommended by the manufacturer for precast floor systems, post tensioned concrete floor systems and other floors subject to movement or deflection.
- Not a roof assembly. (For roof assembly see Detail 325F-2019-2021 Detail A)

### OTHER CONSIDERATIONS

- Refer to Notes For The Professional and 301MJ-2019-2021.
- Waterproofing membrane if required must be specified. (ANSI A118.10) Follow manufacturer's recommendations.
- Uncoupling Membrane – follow manufacturer's recommendations for appropriate mortars: membrane must achieve 0.3 N/mm<sup>2</sup> (50 PSI or greater) shear bond strength after 7 days per the test method in ANSI A118.12 section 5.1.3.
- Bond Coat to Uncoupling membrane- Dry-set mortar (minimum acceptable standard ANSI A118.1 or ISO C1, Latex Portland cement mortar (minimal acceptable standard ANSI A118.4 or ISO C2S1) or Improved Modified Dry-set cement mortar (minimal acceptable standard ANSI A118.15 or ISO C2 F and/or T, and/or S1

# TILE APPLIED OVER WOOD SUBFLOOR IN DRY AREAS

## THIN-SET METHOD

### 313F-2025

#### SUITABLE SUBSTRATES

- Floor systems, including the framing system and subfloor panels, over which the tile will be installed shall be in conformance with the Canadian National Building Code 2020 and applicable local building codes taking into consideration anticipated live and dead loads.

#### MATERIALS

- TILE – meeting ANSI A137.1, A137.2, A137.3, and for areas of use as recommended by the tile manufacturer
- BOND COAT – Latex-Portland cement mortars (minimum acceptable standard ANSI A118.11 or ISO 1307 C2S1), modified epoxy emulsion mortars or 100% solids epoxy mortars (minimum acceptable standard ANSI A118.3 or ISO 1307 R1).
- GROUT – **Interior:** Portland cement, latex-Portland cement (minimum acceptable standard ANSI A118.6 or ISO 13007 CG1), or epoxy grouts (minimum acceptable standard ANSI A118.3 or ISO 13007 RG). **Exterior:** Latex-Portland cement (minimum acceptable standard ANSI A118.6 or ISO 13007 CG1).

#### DETAIL A – THIN-SET ON PLYWOOD

Suitable Sub-floor: Douglas Fir plywood (CSA 0121), Canadian Softwood plywood (CSA 0151), Poplar plywood (CSA 0153), Construction sheathing or APA Sturd-I-Floor, Exposure 1 OSB. Joists to be spaced 406 mm o.c. Apply both layers of panel with top grain at right angles to joist, and with top layer staggered to give 50% overlap of sheets of sub-floor. Gap the top layer of plywood 6 mm between sheets. Underlayment: Only 16 mm or thicker Douglas Fir exterior-grade plywood Select Tight-faced, meeting CSA-0121. Attach underlayment with 30 mm screws or ring shank nails placed 150 mm o.c. around perimeter and 200 mm o.c. throughout the body of the panel. Underlayment screws or ring shank nails to go through the total thickness of the assembly but should not penetrate the joists or cross bridging/solid blocking. Use proper notched trowel to ensure adequate bond. With pressure, apply a coat of mortar by using the trowel's flat side to key the mortar into the substrate. Apply additional mortar, combing it in a single direction parallel to the tile's shortest dimension, with the trowel's notched side. Place the tiles firmly into the wet bond coat. Push the tiles back and forth in a direction perpendicular to trowel lines, to collapse the mortar ridges and to help achieve maximum coverage. Ensure proper contact between mortar, tile and substrate by periodically lifting a few tiles to check for acceptable coverage. Use sufficient bond coat to ensure minimum 80% on interior dry areas. For tile with any edge longer than 380 mm use sufficient bond coat to ensure minimum 95% contact, with the corners and edges fully supported. Remove excess mortar from the joint areas so that at least 2/3 of the tile depth is available for grouting. Allow bond coat to cure. Force grout into the joints with a rubber grout float. Make sure all joints are well-compacted and free of voids and gaps. Remove excess grout from the tile surface and clean.

#### DETAIL B – THIN-SET ON BACKER UNIT/BOARD

Suitable Sub-floor: Douglas Fir plywood (CSA 0121), Canadian Softwood plywood (CSA 0151), Poplar plywood (CSA 0153), Construction sheathing or APA Sturd-I-Floor, Exposure 1 OSB. Underlayment: Minimum 13 mm cementitious backer unit (CBU) or coated glass mat backer board or nominal 11 mm thick fibre-cement backer board meeting ASTM C1288 bedded in latex- Portland cement mortar (minimum acceptable standard ANSI A118.4 or ISO 13007 C2) and gapped 3 mm. Fasten underlayment to sub-floor with 30 mm galvanized screws 200 mm o.c. throughout the body of the panel. Do not countersink screws for coated glass mat backer board. Treat joints as per manufacturer's directions. Apply bond coat, filling gaps in underlayment. Apply bond coat to mortar bed surface. Use proper notched trowel to ensure adequate bond. Use proper notched trowel to ensure adequate bond. With pressure, apply a coat of mortar by using the trowel's flat side to key the mortar into the substrate. Apply additional mortar, combing it in a single direction parallel to the tile's shortest dimension, with the trowel's notched side. Place the tiles firmly into the wet bond coat. Push the tiles back and forth in a direction perpendicular to trowel lines, to collapse the mortar ridges and to help achieve maximum coverage. Ensure proper contact between mortar, tile and substrate by periodically lifting a few tiles to check for acceptable coverage. Use sufficient bond coat to ensure minimum 80% on interior dry areas. For tile with any edge longer than 380 mm use sufficient bond coat to ensure minimum 95% contact, with the corners and edges fully supported. Remove excess mortar from the joint areas so that at least 2/3 of the tile depth is available for grouting. Allow bond coat to cure. Force grout into the joints with a rubber grout float. Make sure all joints are well-compacted and free of voids and gaps. Remove excess grout from the tile surface and clean.

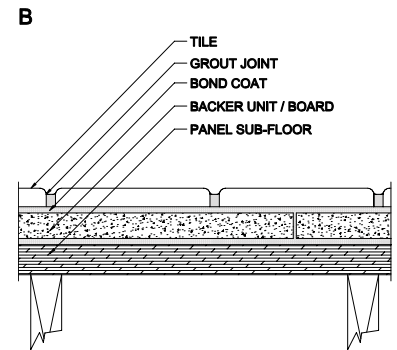
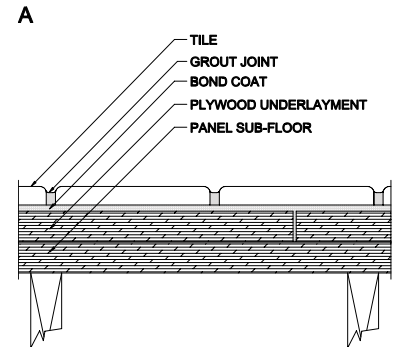

Continued

### DETAIL C – MORTAR BED WITH CLEAVAGE MEMBRANE

Install polyethylene film, place mortar bed (see Tile Guide Specification Section Mixes 2.9.5) at a minimum of 32 mm and a maximum of 51 mm unless stated otherwise by the manufacture. Place 51 mm x 51 mm x 1.6 mm galvanized wire mesh approximately in the middle of the mortar bed as it's being placed (do not place the galvanized wire mesh immediately over or to near the polyethylene film). Finished tolerance of mortar bed not to exceed 6 mm in 3000 mm or 2 mm in 300 mm. More stringent tolerances apply for tiles where any side is greater than 380 mm. Allow mortar to cure. For large format tile where any side is greater than 380 mm, surface variation should not exceed 3 mm in 3000 mm and 1.5 mm in 600 mm. Allow mortar bed to cure. Apply bond coat to cured mortar. Use proper notched trowel to ensure adequate bond. With pressure, apply a coat of mortar by using the trowel's flat side to key the mortar into the substrate. Apply additional mortar, combing it in a single direction parallel to the tile's shortest dimension, with the trowel's notched side. Place the tiles firmly into the wet bond coat. Push the tiles back and forth in a direction perpendicular to trowel lines, to collapse the mortar ridges and to help achieve maximum coverage. Ensure proper contact between mortar, tile and substrate by periodically lifting a few tiles to check for acceptable coverage. Use sufficient bond coat to ensure minimum 80% contact on interior dry areas. For tile with any edge longer than 380 mm use sufficient bond coat to ensure minimum 95% contact, with the corners and edges fully supported. Remove excess mortar from the joint areas so that at least 2/3 of the tile depth is available for grouting. Allow bond coat to cure. Force grout into the joints with a rubber grout float. Make sure all joints are well-compacted and free of voids and gaps. Remove excess grout from the tile surface and clean.

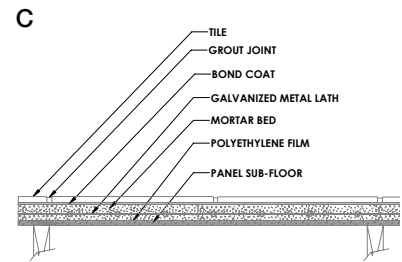

### DETAIL D – THIN-SET ON UNCOUPLING SYSTEM

Suitable Subfloor: Minimum 15 mm Douglas Fir plywood, Canadian Softwood plywood, Poplar plywood, Construction sheathing or APA Sturd-I-Floor, Exposure 1 OSB for joists spaced 406 mm o.c. For floor trusses or I-joists spaced 480 mm o.c., subfloor minimum 20 mm meeting CSA as indicated above. For floor trusses or I-joists spaced 600 mm o.c. subfloor minimum 20 mm with overlay of 10 mm minimum of plywood meeting CSA 0121 or APA Sturd-I-Floor, Exposure 1 OSB, with 3 mm gap between sheets. Underlayment screws or ring shank nails to go through the total thickness of the assembly but should not penetrate the joists or cross bridging/solid blocking. Install uncoupling system to manufacturer's recommendations. Use proper notched trowel to ensure adequate bond. With pressure, apply a coat of mortar by using the trowel's flat side to key the mortar into the substrate. Apply additional mortar, combing it in a single direction parallel to the tile's shortest dimension, with the trowel's notched side. Place the tiles firmly into the wet bond coat. Push the tiles back and forth in a direction perpendicular to trowel lines, to collapse the mortar ridges and to help achieve maximum coverage. Ensure proper contact between mortar, tile and substrate by periodically lifting a few tiles to check for acceptable coverage. Use sufficient bond coat to ensure minimum 80% on interior dry areas. For tile with any edge longer than 380 mm use sufficient bond coat to ensure minimum 95% contact, with the corners and edges fully supported. Remove excess mortar from the joint areas so that at least 2/3 of the tile depth is available for grouting. Allow bond coat to cure. Force grout into the joints with a rubber grout float. Make sure all joints are well-compacted and free of voids and gaps. Remove excess grout from the tile surface and clean. Floor systems, including the framing system and subfloor panels, over which the tile will be installed shall be in conformance with the Canadian National Building Code 2015 and applicable local building codes taking into consideration anticipated live and dead loads. Uncoupling system to be placed over heating system, follow manufacturer's recommendations. For definition of uncoupling system see Glossary.

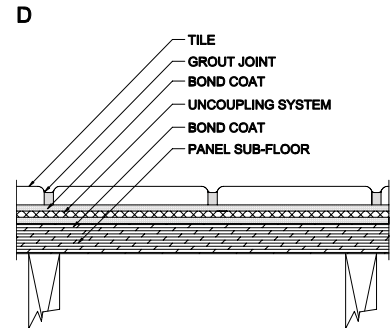

### LIMITATIONS

- For use on interior floors in dry areas. For residential or light commercial use only.
- Waferboard, particleboard and similar products should not be used for subfloors or underlayment.

### OTHER CONSIDERATIONS

- Local practice sometimes incorporates an expanded metal lath attached to the plywood. This is an acceptable method of installation, providing that two layers of plywood is used as per detail (A) and the material used to fill the metal lath is one of the bond coats listed above.
- Cross bridge floor joists but preferably solid blocking.
- Refer to Notes For The Professional and 301MJ-2019-2021.
- When using detail (C), recess floor joist with respect to adjacent areas to accommodate the thickness of the finished tile installation, or use transition strip where tile work abuts other floor coverings.
- For natural stone and some tile larger than 300 mm x 300 mm deflection must not exceed L/720 of span.
- Some thicker uncoupling membranes can be applied on floor trusses and
- I-joists spaced at 600 mm on a single layer subfloor 20 mm minimum thickness.
- Uncoupling Membrane – follow manufacturer's recommendations. Please see page 31 for more information.

✱ **DETAIL E – THIN-SET ON FLOWABLE HYDRAULIC CEMENT UNDERLAYMENT / SELF-LEVELING UNDERLAYMENT**

**SUITABLE SUBSTRATES**

- Minimum tongue & groove 16 mm Douglas Fir plywood, Canadian Softwood plywood, Poplar plywood, Construction sheathing or APA Sturd-I-Floor, Exposure 1 OSB for joists spaced 406 mm o.c. (Consult manufacture for floor trusses or I-joists spaced 480 mm - 600 mm o.c subfloor for suitability and additional requirements.)

**MATERIALS**

- PRIMER – Per manufacturer’s instructions
- GALVANIZED DIAMOND METAL LATH – 1.4 kg/m<sup>2</sup> (ASTM C847-95).
- MORTAR BED – See Tile Guide Specification Section Mixes 2.9.2.5 or cementitious self-levelling underlayment. Primer/Sealer as recommended by manufacturer.
- SUITABLE PANEL SUB-FLOOR – Douglas Fir plywood, Canadian Softwood plywood, Poplar plywood, Construction Sheathing or OSB. Minimum 16 mm exterior grade plywood meeting CSA 0121 or oriented strand board meeting CSA 0437.0 or CSA 0325.0, on joists spaced 406 mm o.c.
- TILE – meeting ANSI A137.1, A137.2 and A137.3
- BOND COAT – Interior: Dry-set mortar (minimum acceptable standard ANSI A118.1 or ISO 13007 C1), latex-Portland cement mortar (minimum acceptable standard ANSI A118.4 or ISO 13007 C2S1), modified epoxy emulsion mortars, 100% solids epoxy mortar, epoxy adhesive (minimum acceptable standard ANSI A118.3 or ISO 13007 R1), or organic adhesives (minimum acceptable standard ANSI A118.3 or ISO 13007 R1). Exterior: Single or two component liquid latex-Portland cement mortar (minimum acceptable standard ANSI A118.4 or ISO 13007 C2S1).
- GROUT – Interior: Portland cement, latex-Portland cement (minimum acceptable standard ANSI A118.6 or ISO CG1), or epoxy grouts (minimum acceptable standard ANSI A118.3 or ISO 13007 RG). Exterior: Latex-Portland cement (minimum acceptable standard ANSI A118.6 or ISO 13007 CG1).

**APPLICATION**

- Apply primer, then attach galvanized wire lath not less than 1.4 kg/m<sup>2</sup> meeting ASTM C847 or equivalent plastic lath. (Some underlayment formulations, including fiber-reinforced formulations, do not require lath)  
Place FHCU/SLU at thickness recommended by manufacturer, typically 6mm - 38mm.  
Optional membranes include waterproofing ANSI A118.10, crack isolation A118.12 or sound attenuation A118.13.  
Use proper notched trowel to ensure adequate bond tile to FHCU/SLU. With pressure, apply a coat of mortar by using the trowel’s flat side to key the mortar into the substrate. Apply additional mortar, combing it in a single direction parallel to the tile’s shortest dimension, with the trowel’s notched side. Place the tiles firmly into the wet bond coat. Push the tiles back and forth in a direction perpendicular to trowel lines, to collapse the mortar ridges and to help achieve maximum coverage. Ensure proper contact between mortar, tile and substrate by periodically lifting a few tiles to check for acceptable coverage. Use sufficient bond coat to ensure minimum 80% on interior dry areas. For tile with any edge longer than 380 mm use sufficient bond coat to ensure minimum 95% contact, with the corners and edges fully supported. Remove excess mortar from the joint areas so that at least 2/3 of the tile depth is available for grouting. Allow bond coat to cure. Force grout into the joints with a rubber grout float. Make sure all joints are well-compacted and free of voids and gaps. Remove excess grout from the tile surface and clean. Floor systems, including the framing system and subfloor panels, over which the tile will be installed shall be in conformance with the Canadian National Building Code 2015 and applicable local building codes taking into consideration anticipated live and dead loads. Substrate is to meet maximum allowable deflection requirements of L/360 per ASTM F2873 for tile installation.

**LIMITATIONS**

- For use on interior floors
- For residential or light commercial use only.
- Waferboard, particleboard and similar products should not be used for subfloors or underlayment.

**OTHER CONSIDERATIONS**

- Cross bridge floor joists but preferably solid blocking.
- Refer to Notes For The Professional and 301MJ-2019-2021.
- For natural stone and some tile larger than 300 mm x 300 mm deflection must not exceed L/720 of span.

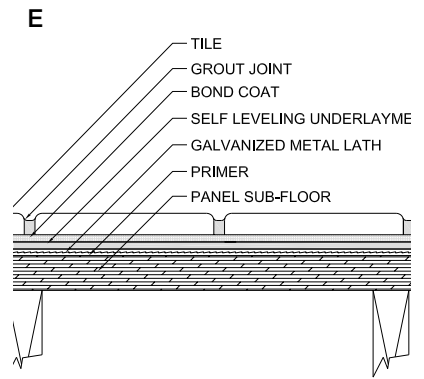

# TILE OVER HEATED FLOOR SYSTEMS

## 314F-2025

### GENERAL GUIDELINES UNDER-FLOOR HEATING

- The under-floor heating system should be installed according to the instructions of the supplier. An incorrectly installed under-floor heating system can cause the screed to become unfastened or the floor covering to lose shape.
- Damage to the floor or the under-floor heating pipes or heating cables resulting from incorrect installation and causing the finish layers to show incomplete covering, is beyond the liability of the installer of the floor and his suppliers.
- After the application of the screed, wait for a minimum of 28 days, then gradually heat up the under-floor heating system by a maximum of 5°C per day.
- Next, make sure the under-floor heating system is switched on uninterruptedly for a period of 14 days, so that the floor can set and any residual moisture can quickly evaporate.
- Switch off the heating system at least 24 hours prior to levelling/applying floor covering.
- Switch on the heating system at least 24 hours after levelling/applying floor covering and gradually raise the water temperature by a maximum of 5°C per day.

### DETAIL A - MORTAR BED OVER PLYWOOD (INTERIOR)

#### SUITABLE SUBSTRATES

- Floor systems, including the framing system and subfloor panels, over which the tile will be installed shall be in conformance with the Canadian National Building Code 2015 and applicable local building codes taking into consideration anticipated live and dead loads.

#### MATERIALS

- CLEAVAGE MEMBRANE – 6 mils polyethylene film or 6.8 kg meeting CAN/CGSB-51.34M, asphalt saturated roofing felt, meeting CSA A123.3-98.
- GALVANIZED DIAMOND METAL LATH – 1.4 kg/m<sup>2</sup> (ASTM C847-95).
- MORTAR BED – See Tile Guide Specification Section Mixes 2.9.2.5 or cementitious self-levelling underlayment. Primer/Sealer as recommended by manufacturer.
- SUITABLE PANEL SUB-FLOOR – Douglas Fir plywood, Canadian Softwood plywood, Poplar plywood, Construction Sheathing or OSB. Minimum 16 mm exterior grade plywood meeting CSA 0121 or oriented strandboard meeting CSA 0437.0 or CSA 0325.0, on joists spaced 406 mm o.c.
- TILE – meeting ANSI A137.1, A137.2 and A137.3
- BOND COAT – **Interior:** Dry-set mortar (minimum acceptable standard ANSI A118.1 or ISO 13007 C1), latex-Portland cement mortar (minimum acceptable standard ANSI A118.4 or ISO 13007 C2S1), modified epoxy emulsion mortars, 100% solids epoxy mortar, epoxy adhesive (minimum acceptable standard ANSI A118.3 or ISO 13007 R1), or organic adhesives (minimum acceptable standard ANSI A118.3 or ISO 13007 R1). **Exterior:** Single or two component liquid latex-Portland cement mortar (minimum acceptable standard ANSI A118.4 or ISO 13007 C2S1).
- GROUT – **Interior:** Portland cement, latex-Portland cement (minimum acceptable standard ANSI A118.6 or ISO CG1), or epoxy grouts (minimum acceptable standard ANSI A118.3 or ISO 13007 RG). **Exterior:** Latex-Portland cement (minimum acceptable standard ANSI A118.6 or ISO 13007 CG1).

#### APPLICATION

- Apply polyethylene film lapped at least 100 mm. Nail galvanized diamond metal lath butted, not overlapped, to the plywood. After the heating/electrical contractor has placed the heating element over the metal or plastic lath, apply mortar bed to required thickness of 32 mm min. Allow mortar bed to cure. Apply bond coat to cured mortar bed. Finished tolerance of mortar bed not to exceed 6 mm in 3000 mm or 2 mm in 300 mm. For large format tile where any side is greater than 380 mm, surface variation should not exceed 3 mm in 3000 mm and 1.5 mm in 600 mm. For tile with any edge longer than 380 mm use sufficient bond coat to ensure minimum 95% contact, with the corners and edges fully supported. Use proper notched trowel to ensure adequate bond. With pressure, apply a coat of mortar by using the trowel's flat side to key the mortar into the substrate. Apply additional mortar, combing it in a single direction parallel to the tile's shortest dimension, with the trowel's notched side. Place the tiles firmly into the wet bond coat. Push the tiles back and forth in a direction perpendicular to trowel lines, to collapse the mortar ridges and to help achieve maximum coverage. Ensure proper contact between mortar, tile and substrate by periodically lifting a few tiles to check for acceptable coverage. Use sufficient bond coat to ensure minimum 80% contact on interior dry areas. Remove excess mortar from the joint areas so that at least 2/3 of the tile depth is available for grouting. Allow bond coat to cure. Force grout into the joints with a rubber grout float. Make sure all joints are well-compacted and free of voids and gaps. Remove excess grout from the tile surface and clean.

#### LIMITATIONS

- Manufacturer's recommendations must be followed.
- The thickness of the mortar bed to be 32 mm minimum interior.
- For residential or light commercial use only.
- Do not use lightweight aggregate in mortar bed.
- If using electric heating cable/conduit, plastic mesh should be used.

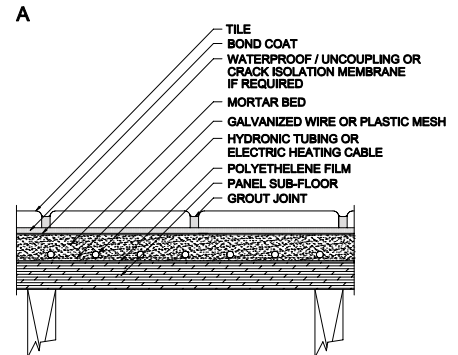

#### OTHER CONSIDERATIONS

- Where incorporating heating cable on interior or exterior concrete substrates is desired, refer to details 309F-2019-2021 and 310F-2019-2021 and incorporate heating cables in the bottom of the mortar bed. When hydronic heating system is used in mortar bed, increase thickness of mortar bed to achieve a minimum 32 mm thickness over heating tubing.
- Certain proprietary systems may allow thin-set installation with latex-Portland cement.
- Heating system - design, installation and inspection by others. Pre heating and testing of the heating system needs to be done prior to the installation of the tile. The tile installation cannot be done when floor heat is in use and may need a minimum of 7 days after tile installation before the radiant heating system can be turned on. Verify with manufacturer
- Refer to Notes For The Professional and 301MJ-2019-2021.
- Movement joints shall be installed at a maximum 3600 mm for radiant heated floors. Width and spacing of joints to be specified by consultant.
- Insulation layer may be required between joists or on top of subfloor for maximum heating efficiency. Consult heating manufacturer for type and thickness.
- Waterproofing membrane (ANSI A118.10) or crack isolation membrane (ANSI A118.12), if required, must be specified. Follow manufacturer's recommendations.
- Uncoupling Membrane – follow manufacturer's recommendations. Please see page 31 for more information.

Continued

# TILE OVER HEATED FLOOR SYSTEMS

## 314F-2025

### DETAIL B – GYPSUM CONCRETE OVER PLYWOOD

#### SUITABLE SUBSTRATES

- Floor systems, including the framing system and subfloor panels, over which the tile will be installed shall be in conformance with the Canadian National Building Code 2015 and applicable local building codes taking into consideration anticipated live and dead loads.

#### MATERIALS

- TILE – meeting ANSI A137.1, A137.2 and A137.3
- SUITABLE PANEL SUB-FLOOR – Douglas Fir plywood, Canadian Softwood plywood, Poplar plywood, Construction Sheathing or OSB. Minimum 16 mm exterior grade plywood meeting CSA 0121 or oriented strandboard meeting CSA 0437.0 or CSA 0325.o, on joists spaced 406 mm o.c.
- GYPSUM CONCRETE – Underlayment meeting performance requirements of ASTM C627 minimum. Compressive strength of 15 MPa when tested by ASTM C472.
- BOND COAT – Dry-set mortar (minimum acceptable standard ANSI A118.1 or ISO 13007 C1), latex-Portland cement mortar (minimum acceptable standard ANSI A118.4 or ISO 13007 C2S1) over gypsum concrete, cured for a minimum of 72 hours or less than 3% residual moisture.
- PRIMER/SEALER – As recommended by manufacturer.
- GROUT - Portland cement, latex-Portland cement (minimum acceptable standard ANSI A118.6 or ISO 13007 CG1), or epoxy grouts (minimum acceptable standard ANSI A118.3 or ISO 13007 RG).

#### APPLICATION

- Following installation of electric heating cable or hydronic tubing (by others), apply gypsum concrete to required thickness over primer/sealer as required by manufacturer. Finished tolerance of gypsum concrete not to exceed 6 mm in 3000 mm or 2 mm in 300 mm. For large format tile any side is greater than 380 mm, surface variation should not exceed 3 mm in 3000 mm and 1.5 mm in 600 mm. For tile with any edge longer than 380 mm use sufficient bond coat to ensure minimum 95% contact, with the corners and edges fully supported. Apply primer/sealer before beginning installation. Use proper notched trowel to ensure adequate bond. With pressure, apply a coat of mortar by using the trowel's flat side to key the mortar into the substrate. Apply additional mortar, combing it in a single direction parallel to the tile's shortest dimension, with the trowel's notched side. Place the tiles firmly into the wet bond coat. Push the tiles back and forth in a direction perpendicular to trowel lines, to collapse the mortar ridges and to help achieve maximum coverage. Ensure proper contact between mortar, tile and substrate by periodically lifting a few tiles to check for acceptable coverage. Use sufficient bond coat to ensure minimum 80% contact on interior dry areas. Remove excess mortar from the joint areas so that at least 2/3 of the tile depth is available for grouting. Allow bond coat to cure. Force grout into the joints with a rubber grout float. Make sure all joints are well-compacted and free of voids and gaps. Remove excess grout from the tile surface and clean.

#### LIMITATIONS

- Manufacturer's recommendations must be followed.
- The thickness of the gypsum concrete should be 15 mm minimum.
- For residential or light commercial use only.

#### OTHER CONSIDERATIONS

- If an uncoupling system is used, one single layer of plywood or or APA Sturd-I-Floor, Exposure 1 OSB with a minimum thickness of 20 mm is acceptable providing the floor trusses or I – joist are spaced at no more than 480 mm o.c.
- Some gypsum concrete underlayment manufacturers recommend the use of plastic lath for application over wood substrate, follow manufacturers recommendations for best practice.
- Cross bridge floor joist but preferably solid blocking.
- Refer to Notes For The Professional and 301MJ-2019-2021.
- Heating system: design, installation and inspection by others. Pre heating and testing of the heating system needs to be done prior to the installation of the tile. The tile installation cannot be done when floor heat is in use and may need a minimum of 7 days after tile installation before the radiant heating system can be turned on. Verify with manufacturer.
- Movement joints shall be installed at a maximum 3600 mm for radiant heated floors. Width and spacing of joints to be specified by consultant.
- Consult membrane manufacturer for maximum residual moisture before installation.
- Uncoupling Membrane – follow manufacturer's recommendations. Please see page 31 for more information.

Continued

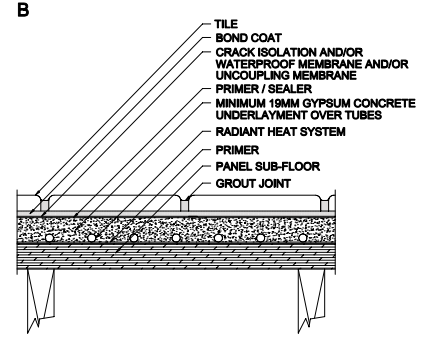

# ✱ TILE OVER HEATED FLOOR SYSTEMS 314F-2025

## DETAIL B2 – FLOWABLE HYDRAULIC CEMENT UNDERLAYMENT / SELF-LEVELING UNDERLAYMENT OVER PLYWOOD

### SUITABLE SUBSTRATES

- Floor systems, including the framing system and subfloor panels, over which the tile will be installed shall be in conformance with the Canadian National Building Code 2015 and applicable local building codes taking into consideration anticipated live and dead loads.

### MATERIALS

- TILE – meeting ANSI A137.1, A137.2, A137.3, and for areas of use as recommended by the tile manufacturer
- SUITABLE PANEL SUB-FLOOR – Douglas Fir plywood, Canadian Softwood plywood, Poplar plywood, Construction Sheathing or OSB. Minimum 16 mm exterior grade plywood meeting CSA 0121 or oriented strand board meeting CSA 0437.0 or CSA 0325.0, on joists spaced 406 mm o.c. (Consult manufacturer for wider spans and truss spacing.)
- PRIMER - Per manufacturer's instructions
- LATH - Galvanized wire lath not less than 1.4 kg/m<sup>2</sup> meeting ASTM C847 or equivalent plastic lath meeting ASTM C1764.
- FHCU/SLU – Underlayment meeting performance requirements of ANSI A118.16
- BOND COAT – Dry-set mortar (minimum acceptable standard ANSI A118.1 or ISO 13007 C1), latex-Portland cement mortar (minimum acceptable standard ANSI A118.4 or ISO 13007 C2S1) after 4 hrs. with rapid hardening FHCU/SLU; >24 hrs. with standard setting.
- GROUT - Portland cement, latex-Portland cement (minimum acceptable standard ANSI A118.6 or ISO 13007 CG1), or epoxy grouts (minimum acceptable standard ANSI A118.3 or ISO 13007 RG).
- Optional MEMBRANES include waterproofing ANSI A118.10, crack isolation A118.12 or sound attenuation A118.13

### APPLICATION

- Apply primer, then attach lath to plywood. (Some underlayment formulations, including fiber-reinforced formulations, do not require lath)
- For hydronic applications that incorporate an attached and approved membrane for FHCU/SLU, follow manufacturer's instructions as lath may be eliminated.
- Place FHCU/SLU at thickness recommended by manufacturer, typically up to 38mm and at least 13mm over hydronic tubing. Finished flatness tolerance not to exceed 6 mm in 3000 mm or 2 mm in 300 mm.
- For large format tile any side is greater than 380 mm, surface variation should not exceed 3 mm in 3000 mm and 1.5 mm in 600 mm. For tile with any edge longer than 380 mm use sufficient bond coat to ensure minimum 95% contact, with the corners and edges fully supported. Apply primer/sealer before beginning installation. Use proper notched trowel to ensure adequate bond. With pressure, apply a coat of mortar by using the trowel's flat side to key the mortar into the substrate. Apply additional mortar, combing it in a single direction parallel to the tile's shortest dimension, with the trowel's notched side. Place the tiles firmly into the wet bond coat. Push the tiles back and forth in a direction perpendicular to trowel lines, to collapse the mortar ridges and to help achieve maximum coverage. Ensure proper contact between mortar, tile and substrate by periodically lifting a few tiles to check for acceptable coverage. Use sufficient bond coat to ensure minimum 80% contact on interior dry areas. Remove excess mortar from the joint areas so that at least 2/3 of the tile depth is available for grouting. Allow bond coat to cure. Force grout into the joints with a rubber grout float. Make sure all joints are well-compacted and free of voids and gaps. Remove excess grout from the tile surface and clean.

### LIMITATIONS

- Manufacturer's recommendations must be followed.
- For residential or light commercial use only.

### OTHER CONSIDERATIONS

- Cross bridge floor joist but preferably solid blocking.
- Refer to Notes For The Professional and 301MJ-2019-2021.
- Heating system: design, installation and inspection by others. Pre-heating and testing of the heating system needs to be done prior to the installation of the tile. The tile installation cannot be done when floor heat is in use and may need a minimum of 7 days after tile installation before the radiant heating system can be turned on. Verify with manufacturer.
- Movement joints shall be installed at a maximum 3600 mm for radiant heated floors. Width and spacing of joints to be specified by consultant.
- Consult membrane and tile manufacturer for maximum residual moisture before installation.
- Uncoupling Membrane – follow manufacturer's recommendations. Please see page 31 for more information. If an uncoupling system is used, one single layer of plywood or or APA Sturd-I-Floor, Exposure 1 OSB with a minimum thickness of 20 mm is acceptable providing the floor trusses or I – joist are spaced at no more than 480 mm o.c.

Continued

✱ B2

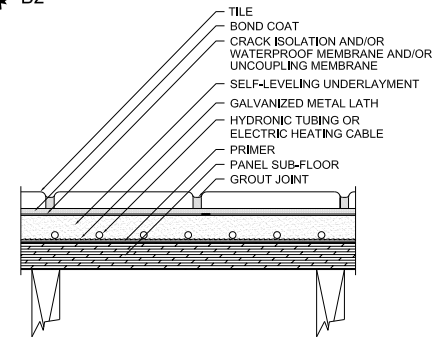

# TILE OVER HEATED FLOOR SYSTEMS

## 314F-2025

### DETAIL C – THIN ELECTRIC HEATING CABLE ON PLYWOOD INTERIOR ONLY

#### SUITABLE SUBSTRATES

- Floor systems, including the framing system and subfloor panels, over which the tile will be installed shall be in conformance with the Canadian National Building Code 2015 and applicable local building codes taking into consideration anticipated live and dead loads.

#### MATERIALS

- TILE – meeting ANSI A137.1, A137.2, A137.3, and for areas of use as recommended by the tile manufacturer
- BOND COAT – Dry-set mortar (minimum acceptable standard ANSI A118.1 or ISO 13007 C1), latex-Portland cement mortar (minimum acceptable standard ANSI A118.4 or ISO 13007 C2S1), modified epoxy emulsion mortars, 100% solids epoxy mortar, epoxy adhesive (minimum acceptable standard ANSI A118.3 or ISO 13007 R1), or organic adhesives (minimum acceptable standard ANSI A118.3 or ISO 13007 R1).
- GROUT - Portland cement, latex-Portland cement (minimum acceptable standard ANSI A118.6 or ISO 13007 CG1), or epoxy grouts (minimum acceptable standard ANSI A118.3 or ISO 13007 RG).

#### APPLICATION

- Following installation of electric heating cable or mat (by others). Use proper notched trowel to ensure adequate bond. With pressure, apply a coat of mortar by using the trowel's flat side to key the mortar into the substrate. Apply additional mortar, combing it in a single direction parallel to the tile's shortest dimension, with the trowel's notched side. Place the tiles firmly into the wet bond coat. Push the tiles back and forth in a direction perpendicular to trowel lines, to collapse the mortar ridges and to help achieve maximum coverage. Ensure proper contact between mortar, tile and substrate by periodically lifting a few tiles to check for acceptable coverage. Use sufficient bond coat to ensure minimum 80% on interior dry areas. For tile with any edge longer than 380 mm use sufficient bond coat to ensure minimum 95% contact, with the corners and edges fully supported. Remove excess mortar from the joint areas so that at least 2/3 of the tile depth is available for grouting. Allow bond coat to cure. Force grout into the joints with a rubber grout float. Make sure all joints are well-compacted and free of voids and gaps. Remove excess grout from the tile surface and clean.

#### LIMITATIONS

- Manufacturer's recommendations must be followed.
- Not to be used in wet areas unless recommended by manufacturer.

#### OTHER CONSIDERATIONS

- If waterproofing/crack isolation membrane is required follow manufacturer's recommendations (ANSI A118.10, ANSI A118.12).
- Heating system - design, installation and inspection by others. Pre heating and testing of the heating system needs to be done prior to the installation of the tile. The tile installation cannot be done when floor heat is in use and may need a minimum of 7 days after tile installation before the radiant heating system can be turned on. Verify with manufacturer.
- Refer to Notes For The Professional and 301MJ-2019-2021.
- Uncoupling system to be placed over heating system. Follow manufacturers' recommendations.
- Insulation layer may be required below plywood subfloor for maximum heating efficiency. Consult heating manufacturer for types and thicknesses.
- Uncoupling Membrane – follow manufacturer's recommendations. Please see page 31 for more information.

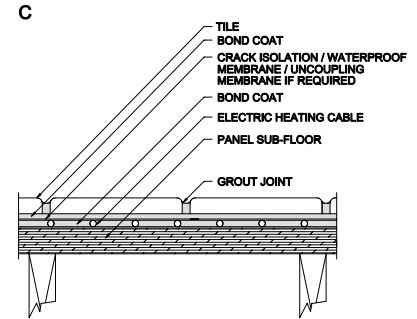

Continued

# TILE OVER HEATED FLOOR SYSTEMS 314F-2025



Please refer to page 7.

## DETAIL C1 – THIN ELECTRIC HEATING CABLE WITH CEMENTITIOUS SELF-LEVELING ON PLYWOOD INTERIOR ONLY

### SUITABLE SUBSTRATES

- Floor systems, including the framing system and subfloor panels, over which the tile will be installed shall be in conformance with the Canadian National Building Code 2015 and applicable local building codes taking into consideration anticipated live and dead loads.

### MATERIALS

- TILE – meeting ANSI A137.1, A137.2, A137.3, and for areas of use as recommended by the tile manufacturer
- BOND COAT – Dry-set mortar (minimum acceptable standard ANSI A118.1 or ISO C1), latex-Portland cement mortar (minimum acceptable standard ANSI A118.4 or ISO C2S1), modified epoxy emulsion mortars, 100% solids epoxy mortar, epoxy adhesive (minimum acceptable standard ANSI A118.3 or ISO R1), or organic adhesives (minimum acceptable standard ANSI A118.3 or ISO R1).
- Crack isolation membrane – ANSI A118.12 or waterproof membrane – ANSI A118.10.
- Uncoupling system to manufacturer's recommendations.
- PRIMER – per manufacturer's recommendations
- FLOWABLE HYDRAULIC CEMENT UNDERLAYMENT / SELF-LEVELING UNDERLAYMENT
- OVER PLYWOOD– as per manufacturer's recommendations.
- CEMENTITIOUS SELF-LEVELLING UNDERLAYMENT – as per manufacturer's recommendations.
- GROUT – Portland cement, latex-Portland cement (minimum acceptable standard ANSI A118.6 or ISO CG1), or epoxy grouts (minimum acceptable standard ANSI A118.3 or ISO RG).

### APPLICATION

- Install electric heating cable or mat (by others).
- Primer must be used over prepared surface as required by self-leveling manufacturer's recommendations.
- Apply thickness of self-leveling to the recommended thickness by manufacturer
- Curing/drying of cementitious self-leveling must be strictly followed as instructed by manufacturer before installation of tile.
- Use proper notched trowel to ensure adequate bond. With pressure, apply a coat of mortar by using the trowel's flat side to key the mortar into the substrate. Apply additional mortar, combing it in a single direction parallel to the tile's shortest dimension, with the trowel's notched side. Place the tiles firmly into the wet bond coat. Push the tiles back and forth in a direction perpendicular to trowel lines, to collapse the mortar ridges and to help achieve maximum coverage. Ensure proper contact between mortar, tile and substrate by periodically lifting a few tiles to check for acceptable coverage. Use sufficient bond coat to ensure minimum 80% on interior dry areas. For tile with any edge longer than 380 mm use sufficient bond coat to ensure minimum 95% contact, with the corners and edges fully supported. Remove excess mortar from the joint areas so that at least 2/3 of the tile depth is available for grouting. Allow bond coat to cure. Force grout into the joints with a rubber grout float. Make sure all joints are well-compacted and free of voids and gaps. Remove excess grout from the tile surface and clean

### LIMITATIONS

- Manufacturer's recommendations must be followed.
- Follow manufacturer's recommendations for manufacturer's maximum applied thicknesses
- Depending on Manufacturer double layer plywood may be required see Detail 313F-A.

### OTHER CONSIDERATIONS

- If waterproofing/crack isolation membrane is required follow manufacturer's recommendations (ANSI A118.10, ANSI A118.12).
- Heating system - design, installation and inspection by others. Pre heating and testing of the heating system needs to be done prior to the installation of the tile. The tile installation cannot be done when floor heat is in use and may need a minimum of 7 days after tile installation before the radiant heating system can be turned on. Verify with manufacturer.
- Refer to Notes For The Professional and 301MJ-2019-2021.
- Insulation layer may be required below plywood subfloor for maximum heating efficiency. Consult heating manufacturer for types and thicknesses.
- Radiant pipe/tube may be substituted for electric wire radiant heat system.
- Electric radiant heat system conforming to UL (CAN/CSA) C22.2 #217.
- Uncoupling Membrane – follow manufacturer's recommendations. Please see page 31 for more information.

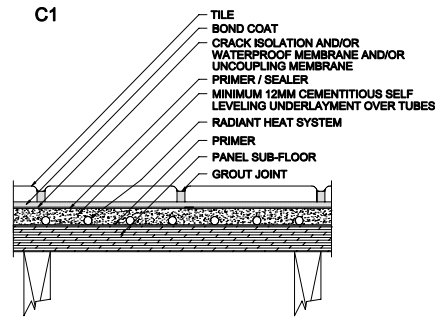

Continued

# TILE OVER HEATED FLOOR SYSTEMS 314F-2025



Please refer  
to page 7.

## DETAIL C2 MODULAR SCREED SYSTEM OVER PLYWOOD INTERIOR ONLY

### SUITABLE SUBSTRATES

- Floor systems, including the framing system and subfloor panels, over which the tile will be installed shall be in conformance with the Canadian National Building Code 2015 and applicable local building codes taking into consideration anticipated live and dead loads.

### MATERIALS

- TILE – meeting ANSI A137.1, A137.2, A137.3, and for areas of use as recommended by the tile manufacturer
- BOND COAT – Dry-set mortar (minimum acceptable standard ANSI A118.1 or ISO 13007 C1 or C2F).
- MODULAR SCREED PANEL – Expanded polystyrene panel with density no less than 32 kg/m<sup>3</sup>.
- GROUT – Portland cement, latex-Portland cement (minimum acceptable standard ANSI A118.6 or ISO 13007 CG1), or epoxy grouts (minimum acceptable standard ANSI A118.3 or ISO 13007 RG).

### APPLICATION

- Apply mortar bed (see Tile Guide Specification Section 2.8.2.5) to required thickness. Finished tolerance of mortar bed not to exceed 6 mm in 3000 mm or 2 mm in 300 mm. For large format tile where any side is greater than 380 mm, surface variation should not exceed 3 mm in 3000 mm and 1.5 mm in 600 mm. For tile with any edge longer than 380 mm use sufficient bond coat to ensure minimum 95% contact, with the corners and edges fully supported. Apply bond coat to mortar bed surface. Use proper notched trowel to ensure adequate bond. With pressure, apply a coat of mortar by using the trowel's flat side to key the mortar into the substrate. Apply additional mortar, combing it in a single direction parallel to the tile's shortest dimension, with the trowel's notched side. Place the tiles firmly into the wet bond coat. Push the tiles back and forth in a direction perpendicular to trowel lines, to collapse the mortar ridges and to help achieve maximum coverage. Ensure proper contact between mortar, tile and substrate by periodically lifting a few tiles to check for acceptable coverage. Use sufficient bond coat to ensure minimum 80%. Remove excess mortar from the joint areas so that at least 2/3 of the tile depth is available for grouting. Allow bond coat to cure. Force grout into the joints with a rubber grout float. Make sure all joints are well-compacted and free of voids and gaps. Remove excess grout from the tile surface and clean.

### LIMITATIONS

- Thickness of the mortar bed should not exceed more than 25 mm above the top of the pedestals of the modular screed panel.
- Verify with manufacturer maximum weight capacity.

### OTHER CONSIDERATIONS

- Refer to Notes For The Professional and 301MJ-2019-2021.
- Insulation layer may be required between joists or on top of subfloor for maximum heating efficiency. Consult manufacturer for type and thickness.
- Heating system - design, installation and inspection by others. Pre heating and testing of the heating system needs to be done prior to the installation of the tile. The tile installation cannot be done when floor heat is in use and may need a minimum of 7 days after tile installation before the radiant heating system can be turned on. Verify with manufacturer.
- Movement joints to be installed only at the tile surface at a maximum of 3600 mm for radiant heated floors. Width and spacing to be determined by consultant or manufacturer.
- Gypsum cement may be substituted for cementitious mortar bed.
- Modular screed panel can be used without radiant heat.
- Uncoupling Membrane – follow manufacturer's recommendations. Please see page 31 for more information.

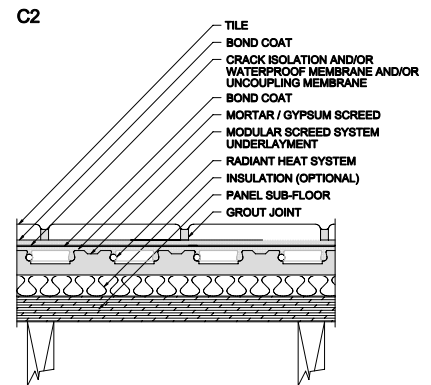

Continued

# TILE OVER HEATED FLOOR SYSTEMS

## 314F-2025



Please refer to page 7.

### DETAIL D – MORTAR BED BONDED TO CONCRETE SLAB – INTERIOR/EXTERIOR

#### SUITABLE SUBSTRATES

- Floor systems over which the tile will be installed shall be in conformance with the Canadian National Building Code 2015 and applicable local building codes taking into consideration anticipated live and dead loads.

#### MATERIALS

- **TILE** – meeting ANSI A137.1, A137.2, A137.3, and for areas of use as recommended by the tile manufacturer.
- **MORTAR BED** – See Tile Specification Section Mixes 2.9.2.5 or cementitious self-levelling underlayment.
- **BOND COAT** – **Interior:** Portland cement slurry on concrete slab and on fresh mortar bed. Dry-set mortar (minimum acceptable standard ANSI A118.1 or ISO 13007 C1), latex-Portland cement mortar (minimum acceptable standard ANSI A118.4 or ISO 13007 C2S1), or modified epoxy emulsion mortars (minimum acceptable standard ANSI A118.3 or ISO 13007 R1), over mortar bed, cured for minimum of 24 hours. 100% solids epoxy mortar on mortar bed, cured a minimum of 7 days. **Exterior:** Two component liquid latex-Portland cement mortar (minimum acceptable standard ANSI A118.4 or ISO 13007 C2S1).
- **GROUT** – **Interior:** Portland cement, latex-Portland cement (minimum acceptable standard ANSI A118.6 or ISO 13007 CG1) or epoxy grouts (minimum acceptable standard ANSI A118.3 or ISO 13007 RG). **Exterior:** latex-Portland cement (minimum acceptable standard ANSI A118.6 or ISO 13007 CG1).

#### APPLICATION

- Following installation of electric heating cable or hydronic tubing (by others), apply mortar bed (see Tile Guide Specification Section Mixes 2.9.2.5) to required thickness over fresh slurry bond coat (see Tile Guide Specification Section Mixes 2.9.2.2). Finished tolerance of mortar bed not to exceed 6 mm in 3000 mm or 2 mm in 300 mm. For large format tile where any side is greater than 380 mm, surface variation should not exceed 3 mm in 3000 mm and 1.5 mm in 600 mm. For tile with any edge longer than 380 mm use sufficient bond coat to ensure minimum 95% contact, with the corners and edges fully supported. Apply Portland cement paste on fresh mortar bed, and dry-set mortar or latex-Portland cement mortar over mortar bed cured for minimum of 24 hours. On fresh mortar bed, beat tile into position. On cured mortar bed, Apply bond coat to mortar bed surface. Use proper notched trowel to ensure adequate bond. With pressure, apply a coat of mortar by using the trowel's flat side to key the mortar into the substrate. Apply additional mortar, combing it in a single direction parallel to the tile's shortest dimension, with the trowel's notched side. Place the tiles firmly into the wet bond coat. Push the tiles back and forth in a direction perpendicular to trowel lines, to collapse the mortar ridges and to help achieve maximum coverage. Ensure proper contact between mortar, tile and substrate by periodically lifting a few tiles to check for acceptable coverage. Use sufficient bond coat to ensure minimum 95% contact on exterior installations and wet areas (it may be necessary to back-butter the tile in order to meet this requirement) and minimum 80% on interior dry areas. Remove excess mortar from the joint areas so that at least 2/3 of the tile depth is available for grouting. Allow bond coat and grout to cure as recommended by the manufacturer for the type of environment and exposure anticipated. Allow bond coat to cure. Force grout into the joints with a rubber grout float. Make sure all joints are well-compacted and free of voids and gaps. Remove excess grout from the tile surface and clean.

#### LIMITATIONS

- Manufacturer's recommendations must be followed.
- The thickness of the mortar bed / cementitious self levelling underlayment should be 32 mm minimum interior and 38 mm minimum exterior above heating pipes.
- Follow manufacturers requirements for maximum moisture content in concrete slab prior to application of underlayment. For example 1.36 kg per 93 m<sup>2</sup> per 24 hours.
- Do not use light weight aggregate in mortar bed.
- For residential or light commercial use only.

#### OTHER CONSIDERATIONS

- Latex additive is recommended for Portland cement bond coat and may be used in modification of mortar bed. Follow manufacturer's recommendations. Use of latex additive in mortar bed and bond coat is mandatory in exterior applications.
- Tile used on exterior applications must be frost resistant.
- Refer to Notes For The Professional and 301MJ-2019-2021.
- Where incorporating heating cable on interior or exterior concrete substrates is desired, refer to details 309F-2019-2021 and 310F-2019-2021 and incorporate heating cables in the bottom of the mortar bed. When hydronic heating is used in mortar bed, increase thickness of mortar bed to give minimum 32 mm of mortar bed over heating tubing.
- Certain proprietary systems may allow thin-set installation with latex-Portland cement as per Detail C and Detail E.
- Heating system: design, installation and inspection by others. Pre heating and testing of the heating system needs to be done prior to the installation of the tile. The tile installation cannot be done when floor heat is in use and may need a minimum of 7 days after tile installation before the radiant heating system can be turned on. Verify with manufacturer.
- Movement joints shall be installed at a maximum 3600 mm for radiant heated floors. Width and spacing of joints to be specified by consultant.
- Latex-Portland cement mortars (minimum acceptable standard ANSI A118.4 or ISO 13007 C2S1) may require 14-60 days cure before exposure to water. Verify with the manufacturer the correct time required. Alternatively, to reduce curing time required, a rapid set mortar (ISO 13007 C1F or C2F) may be more suitable.
- Uncoupling Membrane – follow manufacturer's recommendations. Please see page 31 for more information.

Continued

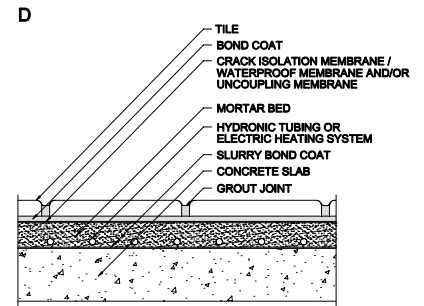

Please refer to page 7.

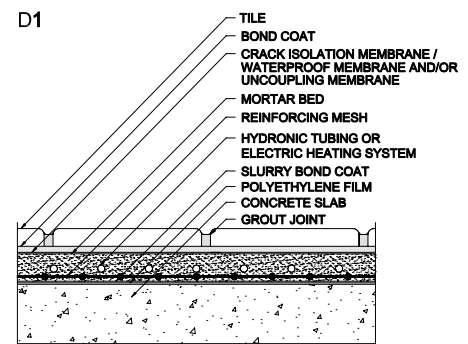

# TILE OVER HEATED FLOOR SYSTEMS 314F-2025



Please refer  
to page 7.

## DETAIL E – THIN-SET ON CONCRETE SLAB INTERIOR ONLY

### SUITABLE SUBSTRATES

- Floor systems, including the framing system and subfloor panels, over which the tile will be installed, shall be in conformance with the Canadian National Building Code 2015 and applicable local building codes taking into consideration anticipated live and dead loads.

### MATERIALS

- TILE – meeting ANSI A137.1, A137.2, A137.3, and for areas of use as recommended by the tile manufacturer
- BOND COAT – Dry-set mortar (minimum acceptable standard ANSI A118.1 or ISO 13007 C1), latex-Portland cement mortar (minimum acceptable standard ANSI A118.4 or ISO 13007 C2S1), modified epoxy emulsion mortars, 100% solids epoxy mortar, epoxy adhesive (minimum acceptable standard ANSI A118.3 or ISO 13007 R1), or organic adhesives (minimum acceptable standard ANSI A118.3 or ISO 13007 R1).
- GROUT – Portland cement, latex-Portland cement (minimum acceptable standard ANSI A118.6 or ISO 13007 CG1), or epoxy grouts (minimum acceptable standard ANSI A118.3 or ISO 13007 RG).

### APPLICATION

- Following installation of electric heating cable or mat (by others). Finished tolerance not to exceed 6 mm in 3000 mm or 2 mm in 300 mm. For large format tile where any side is greater than 380 mm, surface variation should not exceed 3 mm in 3000 mm and 1.5 mm in 600 mm. For tile with any edge longer than 380 mm use sufficient bond coat to ensure minimum 95% contact, with the corners and edges fully supported. Use proper notched trowel to ensure adequate bond. With pressure, apply a coat of mortar by using the trowel's flat side to key the mortar into the substrate. Apply additional mortar, combing it in a single direction parallel to the tile's shortest dimension, with the trowel's notched side. Place the tiles firmly into the wet bond coat. Push the tiles back and forth in a direction perpendicular to trowel lines, to collapse the mortar ridges and to help achieve maximum coverage. Ensure proper contact between mortar, tile and substrate by periodically lifting a few tiles to check for acceptable coverage. Use sufficient bond coat to ensure minimum 80% on interior dry areas. Remove excess mortar from the joint areas so that at least 2/3 of the tile depth is available for grouting. Allow bond coat and grout to cure as recommended by the manufacturer for the type of environment and exposure anticipated. Allow bond coat to cure. Force grout into the joints with a rubber grout float. Make sure all joints are well-compacted and free of voids and gaps. Remove excess grout from the tile surface and clean.

### LIMITATIONS

- Manufacturer's recommendations must be followed.

### OTHER CONSIDERATIONS

- Gypsum concrete underlayment may also be used over wood floors providing that two layers of plywood are used. See detail 313F-2019-2021 drawing (A).
- If an uncoupling system is used, one single layer of plywood minimum thickness of 20 mm is acceptable providing the floor trusses or I – joist are spaced at no more than 480 mm o.c.
- Some gypsum concrete underlayment manufacturers recommend the use of plastic lath for application over wood substrate, follow manufacturers recommendations for best practice.
- Cross bridge floor joist but preferably solid blocking.
- Refer to Notes For The Professional.
- Control joints as per detail 301MJ-2019-2021 and gypsum concrete manufacturer recommendations.
- Heating system - design, installation and inspection by others. Pre heating and testing of the heating system needs to be done prior to the installation of the tile. The tile installation cannot be done when floor heat is in use and may need a minimum of 7 days after tile installation before the radiant heating system can be turned on. Verify with manufacturer.
- Uncoupling Membrane – follow manufacturer's recommendations. Please see page 31 for more information.

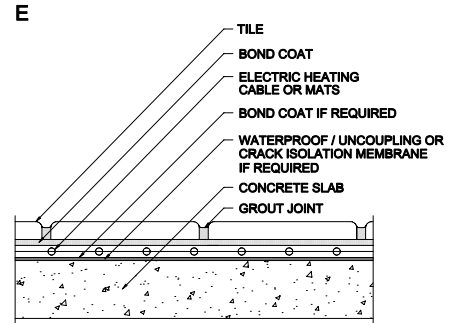

Continued

# TILE OVER HEATED FLOOR SYSTEMS

## 314F-2025



Please refer to page 7.

### DETAIL F – GYPSUM UNDERLAYMENT OVER CONCRETE SLAB

#### SUITABLE SUBSTRATES

- Interior concrete slabs, steel trowel or fine broom finish where no moisture intrusion occurs.
- Floor systems, including the framing system and subfloor panels, over which the tile will be installed shall be in conformance with the Canadian National Building Code 2015 and applicable local building codes taking into consideration anticipated live and dead loads.

#### MATERIALS

- TILE – meeting ANSI A137.1, A137.2, A137.3, and for areas of use as recommended by the tile manufacturer
- BOND COAT – Latex-Portland cement mortar (minimum acceptable standard ANSI A118.4 or ISO 13007 C2), modified epoxy emulsion mortar (minimum acceptable standard ANSI A118.3 or ISO 13007 R1).
- Gypsum concrete underlayment meeting performance requirements of ASTM C627. Minimum compressive strength of 15 MPa when tested by ASTM C472.
- Primer/sealer as per gypsum manufacturer recommendations.
- Crack isolation membrane – ANSI A118.12 or waterproofing membrane – ANSI A118.10.
- Uncoupling system to manufacturer's recommendations.
- Radiant heat system (by others).
- GROUT – Latex-Portland cement (minimum acceptable standard ANSI A118.6 or ISO 13007 CG1), epoxy (minimum acceptable standard ANSI A118.3 or ISO 13007 RG).

#### APPLICATION

- Concrete slab to be well cured, dimensionally stable, free of contaminants such as oil, sealers, hardening or curing chemicals applied to the surface or incorporate in the mix. Following installation of radiant heat system, apply a minimum of 19 mm gypsum concrete underlayment over heating tubes, consult the manufacturer for specific recommendations when used with floor heating system. Finished tolerance of mortar bed not to exceed 6 mm in 3000 mm or 2 mm in 300 mm. For large format tile where any side is greater than 380 mm, surface variation should not exceed 3 mm in 3000 mm and 1.5 mm in 600 mm. For tile with any edge longer than 380 mm use sufficient bond coat to ensure minimum 95% contact, with the corners and edges fully supported. Gypsum underlayment must be fully dry /cured prior to installation of primer / sealer, crack isolation membrane, waterproofing membrane or uncoupling membrane, follow manufacturer's recommendations. Primer / sealer must be compatible with setting material. Use proper notched trowel to ensure adequate bond. With pressure, apply a coat of mortar by using the trowel's flat side to key the mortar into the substrate. Apply additional mortar, combing it in a single direction parallel to the tile's shortest dimension, with the trowel's notched side. Place the tiles firmly into the wet bond coat. Push the tiles back and forth in a direction perpendicular to trowel lines, to collapse the mortar ridges and to help achieve maximum coverage. Ensure proper contact between mortar, tile and substrate by periodically lifting a few tiles to check for acceptable coverage. Use sufficient bond coat to ensure minimum 80% on interior dry areas. Remove excess mortar from the joint areas so that at least 2/3 of the tile depth is available for grouting. Allow bond coat to cure. Force grout into the joints with a rubber grout float. Make sure all joints are well-compacted and free of voids and gaps. Remove excess grout from the tile surface and clean.

#### LIMITATIONS

- Manufacturers recommendations must be followed.
- For residential or light commercial use only.
- Not recommended for below – grade installations and areas subject to extreme moisture.
- Thickness of gypsum concrete should be 15 mm minimum.
- Prior to application of gypsum concrete underlayment consult with waterproofing membrane manufacturer.
- Consult with gypsum concrete manufacturer for proper curing time prior to application of tile and to the minimal time required before heat system is activated.
- Gypsum concrete underlayment installation only by a manufacturer qualified installer in accordance with the manufacturer's instructions and recommendations.

#### OTHER CONSIDERATIONS

- Gypsum concrete underlayment may also be used over wood floors providing that two layers of plywood are used. See detail 313F-2025 drawing (A).
- If an uncoupling system is used, one single layer of plywood minimum thickness of 20 mm is acceptable providing the floor trusses or I – joist are spaced at no more than 480 mm o.c.
- Some gypsum concrete underlayment manufacturers recommend the use of plastic lath for application over wood substrate, follow manufacturers recommendations for best practice.
- Cross bridge floor joist but preferably solid blocking.
- Refer to Notes For The Professional.
- Uncoupling system to be placed over heating system. Follow manufacturers recommendations.
- Control joints as per detail 301MJ-2019-2021 and gypsum concrete manufacturer recommendations.
- Heating system - design, installation and inspection by others. Pre heating and testing of the heating system needs to be done prior to the installation of the tile. The tile installation cannot be done when floor heat is in use and may need a minimum of 7 days after tile installation before the radiant heating system can be turned on. Verify with manufacturer.

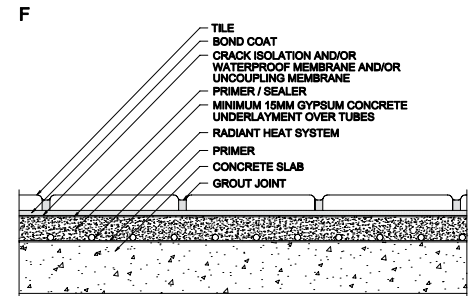

Continued

# TILE OVER HEATED FLOOR SYSTEMS

## 314F-2025

### DETAIL G – MODULAR SCREED SYSTEM

#### SUITABLE SUBSTRATES

- Interior or exterior concrete slabs. Floor systems over which the tile is installed shall be in conformance with the Canadian National Building Code 2015 and applicable local building codes taking into consideration anticipated live and dead loads.

#### MATERIALS

- TILE – meeting ANSI A137.1, A137.2, A137.3, and for areas of use as recommended by the tile manufacturer
- BOND COAT – **Interior:** Dry-set mortar (minimum acceptable standard ANSI A118.1 or ISO 13007 C1), latex-Portland cement mortar (minimum acceptable standard ANSI A118.4 or ISO 13007 C2). **Exterior:** Two component liquid latex-Portland cement mortar (minimum acceptable standard ANSI A118.4 or ISO 13007 C2S1) or follow uncoupling manufacturer's recommendations.
- UNCOUPLING MEMBRANE – following manufacturer's recommendations.
- MODULAR SCREED PANEL – Expanded polystyrene panel with density no less than 32 kg/m<sup>3</sup>.
- GROUT – **Interior:** Portland cement, latex-Portland cement (minimum acceptable standard ANSI A118.6 or ISO 13007 CG1) or epoxy (minimum acceptable standard ANSI A118.3 or ISO 13007 RG). **Exterior:** Latex-Portland cement (minimum acceptable standard ANSI A118.6 or ISO 13007 CG1).

#### APPLICATION

- Apply mortar bed (see Tile Guide Specification Section 2.8.2.5) to required thickness. Finished tolerance of mortar bed not to exceed 6 mm in 3000 mm or 2 mm in 300 mm. For large format tile where any side is greater than 380 mm, surface variation should not exceed 3 mm in 3000 mm and 1.5 mm in 600 mm. For tile with any edge longer than 380 mm use sufficient bond coat to ensure minimum 95% contact, with the corners and edges fully supported. Apply membrane to mortar bed as recommended by manufacturer. Use proper notched trowel to ensure adequate bond. With pressure, apply a coat of mortar by using the trowel's flat side to key the mortar into the substrate. Apply additional mortar, combing it in a single direction parallel to the tile's shortest dimension, with the trowel's notched side. Place the tiles firmly into the wet bond coat. Push the tiles back and forth in a direction perpendicular to trowel lines, to collapse the mortar ridges and to help achieve maximum coverage. Ensure proper contact between mortar, tile and substrate by periodically lifting a few tiles to check for acceptable coverage. Use sufficient bond coat to ensure minimum 95% contact on wet areas (it may be necessary to back-butter the tile in order to meet this requirement) and minimum 80% on interior dry areas. Remove excess mortar from the joint areas so that at least 2/3 of the tile depth is available for grouting. Allow bond coat to cure. Force grout into the joints with a rubber grout float. Make sure all joints are well-compacted and free of voids and gaps. Remove excess grout from the tile surface and clean.

#### LIMITATIONS

- Thickness of the mortar bed should not exceed more than 25 mm above the top of the pedestals of the modular screed panel.
- Verify with manufacturer instructions about maximum weight capacity.

#### OTHER CONSIDERATIONS

- Refer to Notes For The Professional and 301MJ-2019-2021. Extra insulation layer may be required between concrete slab and Modular screed panel. Consult manufacturer for type and thickness.
- Heating system - design, installation and inspection by others. Pre heating and testing of the heating system needs to be done prior to the installation of the tile. The tile installation cannot be done when floor heat is in use and may need a minimum of 7 days after tile installation before the radiant heating system can be turned on. Verify with manufacturer.
- Movement joints to be installed only at the tile surface at a maximum of 3600 mm for radiant heated floors. Width and spacing to be determined by consultant or manufacturer.
- Gypsum cement may be substituted for cementitious mortar bed.
- Modular screed panel can be used without radiant heat.
- In wet areas or in exterior applications a drainage modular screed system can be used to evacuate unwanted water.
- Uncoupling Membrane – follow manufacturer's recommendations. Please see page 31 for more information.

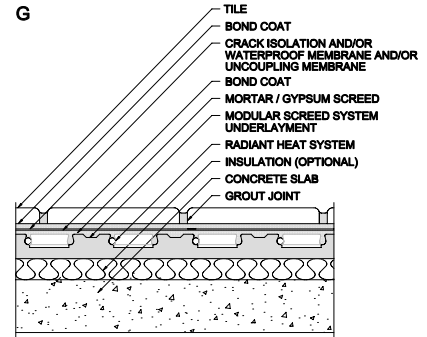

# ✿ TILE OVER HEATED FLOOR SYSTEMS 314F-2025

## DETAIL H – FLOWABLE HYDRAULIC CEMENT UNDERLAYMENT / SELF-LEVELING UNDERLAYMENT OVER CONCRETE SLAB

### SUITABLE SUBSTRATES

- Interior concrete slabs, steel trowel or fine broom finish
- Floor systems, including the framing system and subfloor panels, over which the tile will be installed shall be in conformance with the Canadian National Building Code 2015 and applicable local building codes taking into consideration anticipated live and dead loads.

### MATERIALS

- TILE – meeting ANSI A137.1, A137.2, A137.3, and for areas of use as recommended by the tile manufacturer
- BOND COAT – Latex-Portland cement mortar (minimum acceptable standard ANSI A118.4 or ISO 13007 C2), modified epoxy emulsion mortar (minimum acceptable standard ANSI A118.3 or ISO 13007 R1).
- FHCU/SLU – meeting ANSI A118.16
- Primer as per manufacturer recommendations.
- Crack isolation membrane – ANSI A118.12 or waterproofing membrane – ANSI A118.10.
- Uncoupling system to manufacturer's recommendations.
- Radiant heat system (by others).
- GROUT – Latex-Portland cement (minimum acceptable standard ANSI A118.6 or ISO 13007 CG1), epoxy (minimum acceptable standard ANSI A118.3 or ISO 13007 RG).

### APPLICATION

- Concrete slab to be well cured, dimensionally stable, free of contaminants such as oil, sealers, hardening or curing chemicals applied to the surface or incorporate in the mix. Following installation of radiant heat system, apply a minimum of 6 mm FHCU/ SLU over heating tubes, consult the manufacturer for specific recommendations when used with floor heating system. Finished tolerance of FHCU/SLU not to exceed 6 mm in 3000 mm or 2 mm in 300 mm. For large format tile where any side is greater than 380 mm, surface variation should not exceed 3 mm in 3000 mm and 1.5 mm in 600 mm. For tile with any edge longer than 380 mm use sufficient bond coat to ensure minimum 95% contact, with the corners and edges fully supported.  
FHCU/SLU to cure >4hrs for rapid-hardening or 24 hrs. for standard setting prior to installation of crack isolation membrane, waterproofing membrane or uncoupling membrane, follow manufacturer's recommendations.  
Use proper notched trowel to ensure adequate bond. With pressure, apply a coat of mortar by using the trowel's flat side to key the mortar into the substrate. Apply additional mortar, combing it in a single direction parallel to the tile's shortest dimension, with the trowel's notched side. Place the tiles firmly into the wet bond coat. Push the tiles back and forth in a direction perpendicular to trowel lines, to collapse the mortar ridges and to help achieve maximum coverage. Ensure proper contact between mortar, tile and substrate by periodically lifting a few tiles to check for acceptable coverage. Use sufficient bond coat to ensure minimum 80% on interior dry areas. Remove excess mortar from the joint areas so that at least 2/3 of the tile depth is available for grouting. Allow bond coat to cure. Force grout into the joints with a rubber grout float. Make sure all joints are well-compacted and free of voids and gaps. Remove excess grout from the tile surface and clean.

### LIMITATIONS

- Manufacturer's recommendations must be followed.
- For residential or light commercial use only.
- Use moisture mitigation system meeting ASTM F3010 for areas with moisture vapor emissions higher than assembly component limitations

### OTHER CONSIDERATIONS

- Refer to Notes For The Professional.
- Membranes or uncoupling systems to be placed over heating system. Follow manufacturers recommendations.
- Movement joints as per detail 301MJ-2019-2021 recommendations.
- Heating system - design, installation and inspection by others. Pre heating and testing of the heating system needs to be done prior to the installation of the tile. The tile installation cannot be done when floor heat is in use and may need a minimum of 7 days after tile installation before the radiant heating system can be turned on. Verify with manufacturer.

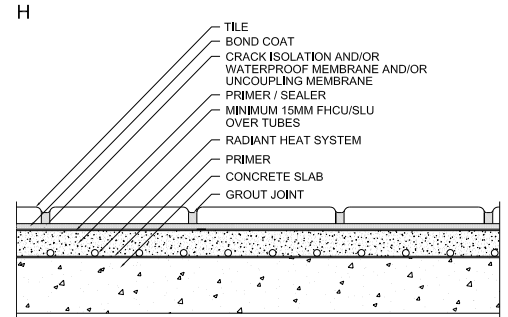

# TILE INSTALLED ON INTERIOR/EXTERIOR CEILINGS OR SOFFITS

## 315C-2025

### DETAIL A – MORTAR BED OVER CONCRETE

#### SUITABLE SUBSTRATES

- Clean, sound, stable concrete.

#### MATERIALS

- **TILE** – meeting ANSI A137.1, A137.2, A137.3, and for areas of use as recommended by the tile manufacturer
- **METAL LATH** (optional) 1.4 kg/m<sup>2</sup> (ASTM C847 corrosion resistant lath).
- **SCRATCH COAT** (7 mm minimum). See Tile Guide Specification Section Mixes 2.9.2.1.
- **MORTAR BED** – (20 mm+). See Tile Guide Specification Section Mixes 2.9.2.3.
- **BOND COAT** – **Interior:** Portland cement slurry on fresh mortar bed, latex-Portland cement mortars (minimum acceptable standard ANSI A118.4 or ISO 13007 C2) or dry-set mortar (minimum acceptable standard ANSI A118.1 or ISO 13007 C1) on mortar bed cured for minimum of 24 hours. See Tile Guide Specification Section Mixes 2.9.2.3 Metal Lath may be required for surfaces that present bonding problems. **Exterior:** Single or two component liquid latex-Portland cement mortar (minimum acceptable standard ANSI A118.4 or ISO 13007 C2S1).
- **GROUT** – **Interior:** Latex-Portland cement (minimum acceptable standard ANSI A118.6 or ISO 13007 CG1) or epoxy (minimum acceptable standard ANSI A118.3 or ISO 13007 RG). **Exterior:** Latex-Portland cement (minimum acceptable standard ANSI A118.6 or ISO 13007 CG1).

#### APPLICATION

- Attach metal lath, if required, according to manufacturer's recommendations. Apply scratch coat and cure overnight. Apply mortar bed to required thickness. Finished tolerance of mortar bed not to exceed 6 mm in 3000 mm or 2 mm in 300 mm. For large format tile where any side is greater than 380 mm, surface variation should not exceed 3 mm in 3000 mm and 1.5 mm in 600 mm. Use proper notched trowel to ensure adequate bond. With pressure, apply a coat of mortar by using the trowel's flat side to key the mortar into the substrate. Apply additional mortar, combing it in a single direction parallel to the tile's shortest dimension, with the trowel's notched side. Place the tiles firmly into the wet bond coat. Push the tiles back and forth in a direction perpendicular to trowel lines, to collapse the mortar ridges and to help achieve maximum coverage. Ensure proper contact between mortar, tile and substrate by periodically lifting a few tiles to check for acceptable coverage. Use sufficient bond coat to ensure minimum 95% contact on exterior installations and wet areas and minimum 80% on interior dry areas (back buttering is required on ceilings). Remove excess mortar from the joint areas so that at least 2/3 of the tile depth is available for grouting. Allow bond coat to cure. Force grout into the joints with a rubber grout float. Make sure all joints are well-compacted and free of voids and gaps. Remove excess grout from the tile surface and clean.

#### LIMITATIONS

- Manufacturer's recommendations must be followed.
- Do not use paper-back or mesh-back mounted tile for exterior use or in locations of extreme moisture unless the manufacturer guarantees that the material is suitable for this type of installation.
- For thin-set method concrete surface must be clean, dimensionally stable, cured and free of contaminants such as oil, sealers, paint and curing compounds or any deleterious substances that may reduce or prevent proper bonding.

#### OTHER CONSIDERATIONS

- Latex additive is recommended for modification of scratch coat, mortar bed and Portland cement bond coat. Follow manufacturer's recommendations. Where job conditions require additional thickness, allow 24 hours cure between coats.
- Tile used on exterior applications must be frost resistant.
- Refer to Notes For The Professional and 301MJ-2019-2021.
- Waterproofing membrane if required must be specified. (ANSI A118.10)
- Follow manufacturer's recommendations
- Latex-Portland cement mortars may require 14 – 60 days cure before exposure to water. Verify with the manufacturer the correct cure time required. Alternatively, to reduce the curing time required, a rapid set mortar may be more suitable.
- For ease of installation a non sag mortar or light weight mortar may be considered.
- For thin-set applications see Detail A-2.

Continued

A1

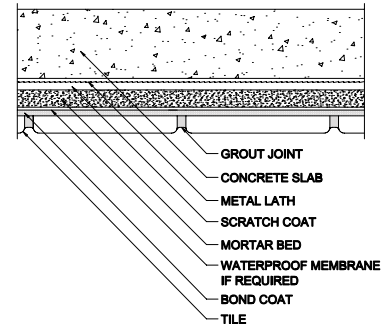

A2

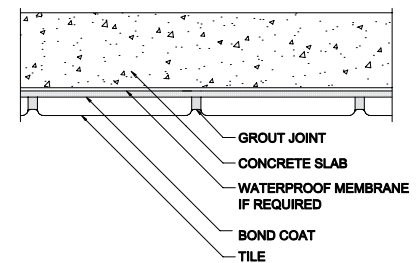

# TILE INSTALLED ON INTERIOR/EXTERIOR CEILINGS OR SOFFITS

## 315C-2025

### DETAIL B – THIN-SET METHOD OVER BACKER UNIT/BOARD

#### SUITABLE SUBSTRATES

- Wood or metal studs, maximum 406 mm o.c.

#### MATERIALS

- VAPOUR RETARDER – 6 mils polyethylene film – required in wet areas.
- Cementitious backer units (CBU) (ANSI A118.9) or coated glass mat backer board (ASTM C1178) or gypsum board (ASTM C36) (dry areas only).
- TILE – meeting ANSI A137.1, A137.2, A137.3, and for areas of use as recommended by the tile manufacturer
- TAPE – Alkali-resistant fibre-mesh at least 51 mm wide
- SLIGHT LEVELLING COAT – if required
- BOND COAT – **Interior:** Latex-Portland cement (minimum acceptable standard ANSI A118.4 or ISO 13007 C2), mortar, dry-set mortar (minimum acceptable standard ANSI A118.1 or ISO 13007 C1) or modified epoxy emulsion mortar (minimum acceptable standard ANSI A118.3 or ISO 13007 R1). **Exterior:** Two component liquid latex-Portland cement mortar (minimum acceptable standard ANSI A118.4 or ISO 13007 C2S1).
- GROUT – **Interior:** Latex-Portland cement (minimum acceptable standard ANSI A118.6 or ISO 13007 CG1), epoxy (minimum acceptable standard ANSI A118.3 or ISO 13007 RG). **Exterior:** Latex-Portland cement (minimum acceptable standard ANSI A118.6 or ISO 13007 CG1).

#### APPLICATION

- Cementitious backer unit (CBU) or coated glass mat backer board must be level, stable, square and screwed to studs with corrosion resistant screws. Do not countersink screws. Surface variation in the backing not to exceed 6 mm in 3000 mm or 2 mm in 300 mm. For large format tile where any side is greater than 380 mm, surface variation should not exceed 3 mm in 3000 mm and 1.5 mm in 600 mm. Apply levelling coat if required. All joints must be taped with 51 mm fibre mesh tape, filled with a dry-set or latex mortar, and sanded. Do not sand coated glass mat backer board unless a waterproofing membrane is used after sanding. Use proper notched trowel to ensure adequate bond. With pressure, apply a coat of mortar by using the trowel's flat side to key the mortar into the substrate. Apply additional mortar, combing it in a single direction parallel to the tile's shortest dimension, with the trowel's notched side. Place the tiles firmly into the wet bond coat. Push the tiles back and forth in a direction perpendicular to trowel lines, to collapse the mortar ridges and to help achieve maximum coverage. Ensure proper contact between mortar, tile and substrate by periodically lifting a few tiles to check for acceptable coverage. Use sufficient bond coat to ensure minimum 95% contact on exterior installations and wet areas and minimum 80% on interior dry areas (back buttering is required on ceilings). Remove excess mortar from the joint areas so that at least 2/3 of the tile depth is available for grouting. Allow bond coat to cure. Force grout into the joints with a rubber grout float. Make sure all joints are well-compacted and free of voids and gaps. Remove excess grout from the tile surface and clean.

#### LIMITATIONS

- Manufacturer's recommendations must be followed.
- Exterior tile installations should not be attempted when temperature is less than 12°C unless otherwise stated by manufacturer.
- Do not use paper-back or mesh-back mounted tile for exterior use or in locations of extreme moisture unless the manufacturer guarantees that the material is suitable for this type of installation.
- Framing for ceiling shall be capable of supporting weight of tile and backup system.
- A waterproofing membrane or vapour retarder not to be used behind coated glass mat backer board.
- All requirements for exterior applications must be met.
- Coated glass mat backer board is not recommended for exterior applications.

#### OTHER CONSIDERATIONS

- Spacing and minimum gauge of steel studs as per instructions of manufacturer of cementitious backer unit (CBU) or coated glass mat backer board on exterior installation.
- Waterproofing membrane if required must be specified. (ANSI A118.10) Follow manufacturer's recommendations.
- Tile used on exterior applications must be frost resistant.
- Refer to Notes For The Professional and 301MJ-2019-2021.
- For high use showers (hotels, gang showers, sports facilities, etc.) a waterproofing membrane shall be used.
- All openings and cuts must be treated to ensure waterproof integrity.
- Latex-Portland cement mortars may require 14 – 60 days cure before exposure to water. Verify with the manufacturer the correct cure time required. Alternatively, to reduce the curing time required, a rapid set mortar may be more suitable.

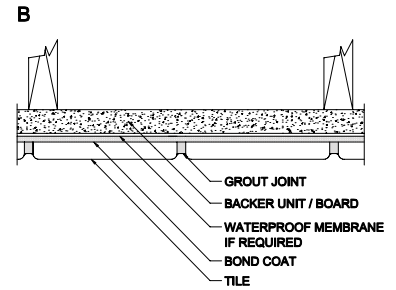

# TILE TUB OVER WOOD FRAME - THIN-SET METHOD OVER MORTAR BED

## 316B-2025



Please refer to page 7.

### SUITABLE SUBSTRATES

- Minimum 16 mm exterior-grade plywood over wood joist, maximum 406 mm o.c. covered with waterproof membrane.

### MATERIALS

- TILE – meeting ANSI A137.1, A137.2, A137.3, and for areas of use as recommended by the tile manufacturer
- METAL LATH – 1.4 kg/m<sup>2</sup> (ASTM C847).
- MORTAR BED – Minimum 20 mm on vertical surface, and 32 mm on horizontal surface. See Tile Guide Specification Section Mixes 2.9.2.5.
- WATERPROOFING MEMBRANE – meets ANSI A118.10
- BOND COAT – Latex-Portland cement mortar (minimum acceptable standard ANSI A118.4 or ISO 13007 C2 or better).
- GROUT – Portland cement, latex-Portland cement (minimum acceptable standard ANSI A118.6 or better or ISO 13007 CG1) or epoxy (minimum acceptable standard ANSI A118.3 or ISO 13007 RG).

### APPLICATION

- Install waterproofing membrane over plywood following manufacturers' recommendations. Installation of drainage fittings and testing for leaks by others prior to tile work. Install metal lath attaching only to substrate above water line. Apply scratch coat. Let cure 24 hours minimum. Apply mortar bed to required thickness and let cure minimum of 48 hours. Finished tolerance of mortar bed not to exceed 6 mm in 3000 mm or 2 mm in 300 mm. For large format tile where any side is greater than 380 mm, surface variation should not exceed 3 mm in 3000 mm and 1.5 mm in 600 mm. Slope floor to drain. Use proper notched trowel to ensure adequate bond. With pressure, apply a coat of mortar by using the trowel's flat side to key the mortar into the substrate. Apply additional mortar, combing it in a single direction parallel to the tile's shortest dimension, with the trowel's notched side. Place the tiles firmly into the wet bond coat. Push the tiles back and forth in a direction perpendicular to trowel lines, to collapse the mortar ridges and to help achieve maximum coverage. Use sufficient bond coat to ensure minimum 95% contact in wet areas (it may be necessary to back-butter the tile in order to meet this requirement). Beat mosaic into position. Allow bond coat to cure minimum 7 days before grouting. Remove excess mortar from the joint areas so that at least 2/3 of the tile depth is available for grouting. Allow bond coat to cure. Force grout into the joints with a rubber grout float. Make sure all joints are well-compacted and free of voids and gaps. Remove excess grout from the tile surface and clean.

### LIMITATIONS

- For use on interior applications only.

### OTHER CONSIDERATIONS

- Under conditions of low temperatures or high humidity, required drying time before grouting can vary from 14 to 60 days. Where job conditions permit, longer drying time is recommended.
- Drains should be designed to permit drainage of water at the tile surface and the surface of the waterproofing membrane.
- For drainage see Detail 326DR-2019-2021.
- Where necessary provide a control joint around perimeter of curb.
- Shorter curing times may be achieved with specific products as recommended by the manufacturer.
- For installation of waterproofing membrane follow manufacturer's recommendations (ANSI A118.10).
- Refer to Notes For The Professional and 301MJ-2019-2021.
- For high use showers (hotels, gang showers, sports facilities, etc.) refer to Detail 319SR-2019-2021 Detail A & B. All openings and cuts must be treated to ensure waterproof integrity.
- Latex-Portland cement mortars may require 14 – 60 days cure before exposure to water. Verify with the manufacturer the correct cure time required. Alternatively, to reduce the curing time required, a rapid set mortar may be more suitable.
- If required, an underbed may be installed over a fresh scratch coat.

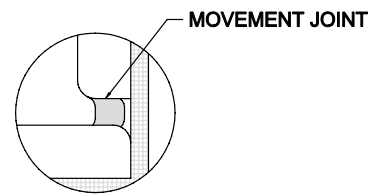
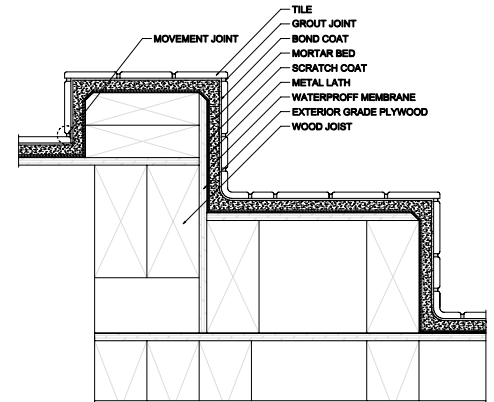

# TILE INSTALLED OVER CONCRETE IN SWIMMING POOLS OR TANKS

## 317SP-2025



Please refer to page 7.

### SUITABLE SUBSTRATES

- Interior or exterior: cured concrete designed for no deflection when pool or tank is full.

### MATERIALS

- TILE – meeting ANSI A137.1, A137.2, A137.3, and for areas of use as recommended by the tile manufacturer
- Scratch coat mortar bed and bond coat to be single or 2 component liquid latex-Portland cement mortar (minimum acceptable standard ANSI A118.4 or ISO 13007 C2S1).
- GROUT – Latex modified grout (minimum acceptable standard ANSI A118.6 or ISO 13007 CG1) qualified for swimming pool installations, epoxy grout (minimum acceptable standard ANSI A118.3 or ISO 13007 RG).
- Waterproofing membrane (ANSI A118.10).

### APPLICATION

- Apply slight levelling coat as required. Install waterproofing membrane over concrete according to manufacturers' recommendations. Installation of fittings and testing for leaks by others prior to tile work. Apply bond coat and grout as per detail 316B-2019-2021. For detail (B), install scratch coat (see Tile Guide Specification Section Mixes 2.9.2.1) and mortar bed (see Tile Guide Specification Section Mixes 2.9.2.3) in accordance with 302W-2019-2021 and 310F-2019-2021 and cure minimum of seven days, unless otherwise stated by manufacturer of pre-mixed material system. Plan for and make slopes to the bottom drains. Finished tolerance of mortar bed not to exceed 6 mm in 3000 mm or 2 mm in 300 mm. Use proper notched trowel to ensure adequate bond. With pressure, apply a coat of mortar by using the trowel's flat side to key the mortar into the substrate. Apply additional mortar, combing it in a single direction parallel to the tile's shortest dimension, with the trowel's notched side. Place the tiles firmly into the wet bond coat. Push the tiles back and forth in a direction perpendicular to trowel lines, to collapse the mortar ridges and to help achieve maximum coverage. Ensure proper contact between mortar, tile and substrate by periodically lifting a few tiles to check for acceptable coverage. Use sufficient bond coat to ensure minimum 95% contact with back of tile (it may be necessary to back-butter the tile in order to meet this requirement). Beat mosaic tile into position. Remove excess mortar from the joint area so that at least 2/3 of the tile depth is available for grouting. Allow bond coat to dry a minimum seven days before grouting. Force grout into the joints with a rubber grout float. Make sure all joints are well-compacted and free of voids and gaps. Remove excess grout from the tile surface and clean.

### LIMITATIONS

- Ensure bond coat is compatible with waterproofing membrane.
- Manufacturer's recommendations must be followed. Exterior tile installations should not be attempted with a temperature of less than 12°C unless otherwise stated by manufacturer.
- Thin-set application substrate surface variation not to exceed 6 mm in 3000 mm and/or 2 mm in 300 mm. For large format tile where one edge is 380 mm or larger, surface variation should not exceed 3 mm in 3000 m. For a slight substrate irregularity, a latex Portland cement mortar or an epoxy mortar levelling coat may be required prior to installation by a thin-set method up to 5 mm thick and allowed to set before application of other materials. A levelling coat in excess of 5 mm should be installed with the mortar bed method. If required, the method must be specified by the consultant.

Continued

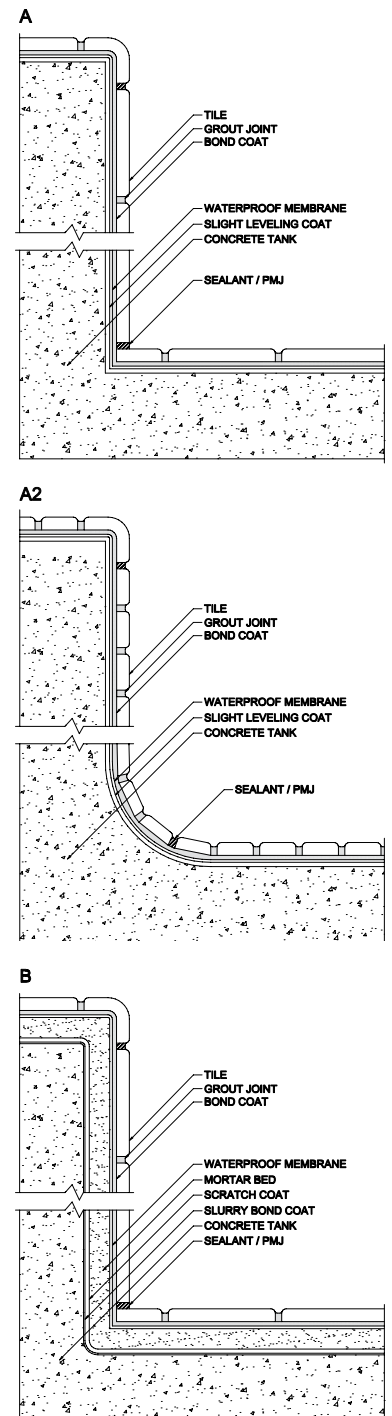

#### OTHER CONSIDERATIONS

- Under conditions of low temperature or high humidity, drying time before grouting can vary from 14 to 60 days. Where job conditions permit, longer drying time is recommended. Swimming pools used in competition must have accurate dimensions, which may require use of detail (B) to meet tolerances. Waterproofing membrane may be eliminated if concrete tank is constructed to be watertight or if tank is installed in ground with suitable drainage provided. Provide drains to permit drainage of water at the tile surface and the surface of the waterproofing membrane. For drainage see Detail 326DR-2025.
- Tile must be moisture resistant.
- Tile used on exterior applications must be frost resistant.
- Shorter curing times may be achieved with specific products as recommended by the manufacturer.
- For ease of maintenance of the movement joints during the service life of the pool consider using prefabricated movement joints (PMJ) in movement joints throughout the field of the installation and in corners.
- Refer to Notes For The Professional and 301MJ-2025.
- Considering that tile installation in pool facilities are very detailed work. The installation shall be performed by skilled mechanics trained and experienced in tile work with a minimum of five years of proven experience in projects of similar size and scope. If requested by Consultant, installer shall provide a listing of previously completed projects of similar size and scope.
- All pipes and protrusions must be treated to ensure waterproof integrity.
- Proceed with a water immersion test (water-filling) to check complete waterproof qualities of the pool after the waterproofing membrane as properly cured.
  - The rate of draining and /or filling must be maintained between 60 and 75 cm/24 hours during the immersion test and any time during the first year.
  - After the first year, draining and filling rate can be increased to 1.5 m/24 hours .
  - The difference in temperature between the tiled surface and the filling water must not exceed 10°C.

# TILE INSTALLED ON INTERIOR/EXTERIOR STAIRS

## 318S-2025

### (A) STEEL PAN

- Steel rod and reinforcing mesh approximately 13 mm above pan bottom. Application as per Detail 309F-2025 but omit cleavage membrane or vapour retarder.

### (B) STEEL STAIRS

- Metal lath fastened to metal stair on steel treads and risers by tie wires or spot welded by steel fabricator. Application as per Detail 308W-2025 but omit cleavage membrane or vapour retarder.

### (C) WOOD STAIRS - INTERIOR ONLY

- Nail galvanized metal lath to wood substrate over cleavage membrane (vapour retarder). Install mortar bed and tile according to Detail 308W-2025 but increase thickness of mortar bed on horizontal surface to a minimum of 32 mm.

- (D) Application of materials as per Detail 310F-2025 (A) for treads and 302W-2025 for risers.

- (E) Application of material as per Detail 303W-2025 and 311F-2025 but apply slight levelling coat to substrate if required and cure a minimum of 24 hours before application of tile.

### LIMITATIONS

- Organic adhesives are not acceptable for these applications.

### OTHER CONSIDERATIONS

- For easy maintenance, use cove base tile or cove movement profile at junction of riser and tread. Wood stairs not recommended for exterior applications. On exterior stairs, a slight slope on treads is preferred to provide drainage. Provide tactile surface prior to stairs where required for visually handicapped. Where required, use a 51 mm strip of contrasting colour at edge of first and last step.
- Precast terrazzo and natural stone tile may be used providing that slip resistant properties are acceptable.
- For detail B and C, mortar bed may be installed over fresh scratch coat.
- Prefabricated stair nosings or carborundum inserts should be used for increased safety precautions.
- Slip resistance for stair treads must be a minimum of 0.6 wet or dry.
- Tile used in exterior applications must be frost resistant. Consult with manufacturer for DCOF recommendations.
- To minimize the potential for cracking use a sealant or prefabricated movement joint at the junction between the riser and tread.
- For exterior applications a waterproofing membrane is recommended. Follow manufacturer's recommendations (ANSI A118.10).
- Stair risers to be not less than 125 mm and not more than 180 mm.
- Treads & risers must have uniform rise and run in any one flight.
- Treads must have run not less than 280 mm between successive steps.
- Stair nosing cannot be canter levered over the riser and edge. The leading edge of the stair tread shall have either a radius or a bevel between 8 mm and 13 mm in horizontal dimensions.
- Refer to Notes For The Professional and 301MJ-2025.
- For Detail A, B, D, and E use sufficient bond coat to ensure a minimum 95% contact on exterior installations and wet areas (it may be necessary to back-butter the tile in order to meet this requirement). and minimum 80% on interior areas.
- For Detail C use sufficient bond coat to ensure minimum 80% contact.

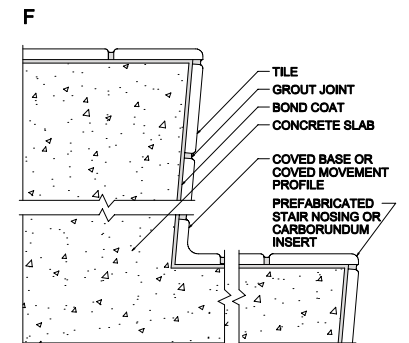
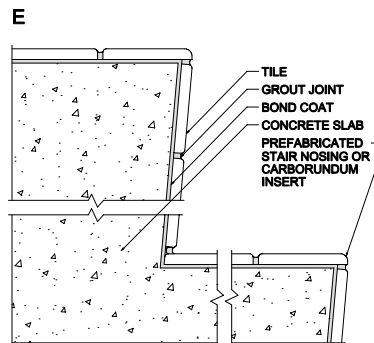
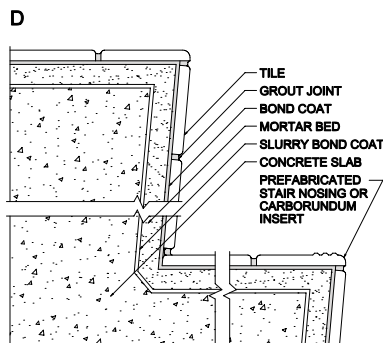
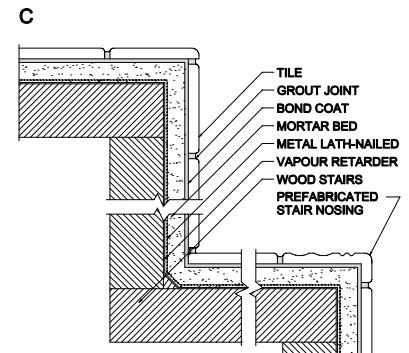
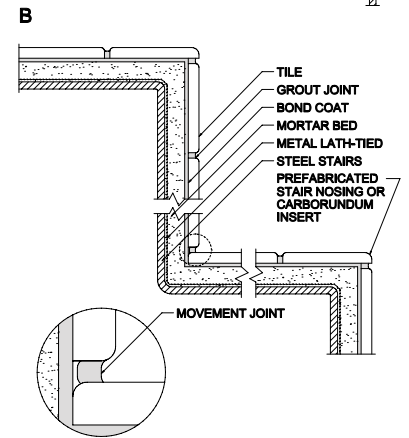
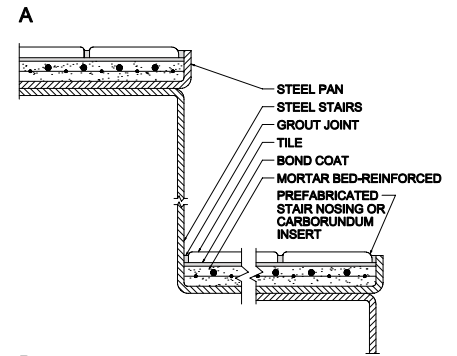

# TILE ON SHOWER RECEPTORS

## 319SR-2025

### DETAIL A - ON SOLID BACKING OR MORTAR BED OVER WOOD OR METAL STUDS

#### SUITABLE SUBSTRATES

- Shower pan or waterproofing membrane over structural base.
- Wall constructed in accordance with Details 303W-2025, 307W-2025 and 308W-2025.

#### MATERIALS

- TILE – meeting ANSI A137.1, A137.2, A137.3, and for areas of use as recommended by the tile manufacturer
- SHOWER PAN OR MEMBRANE – Installed over sloped base.
- MORTAR BED – Minimum of 32 mm to 51 mm sloped to drain. See Tile Guide Specification Mixes 2.9.2.5.
- BOND COAT – Portland cement paste on fresh mortar bed, and dry set mortar (minimum acceptable standard ANSI A118.1 or ISO 13007 C1) or latex-Portland cement mortar (ANSI A118.4 or ISO 13007 C2) or modified epoxy emulsion mortar (ANSI A118.3 or ISO 13007 R1) over mortar bed cured for minimum of 24 hours.
- GROUT – Portland cement or latex-Portland cement (minimum acceptable standard ANSI A118.6 or ISO 13007 CG1), epoxy grout (minimum acceptable standard ANSI A118.3 or ISO 13007 RG).

#### APPLICATION

- Provide 6 mm in 300 mm slope to drain in floor. For heavy duty installations, wall constructed according to Detail 303W-2025, 307W-2025 or 308W-2025 is recommended. Carry membrane or pan at least 75 mm above shower curb, or 150 mm above floor in showers without curbs. Latex additive use in place of water is recommended for Portland cement bond coat, and may be used in modification of mortar bed.

#### LIMITATIONS

- Do not use paper back or mesh back mounted tile in wet areas unless the manufacturer guarantees that the material is suitable for this type of installation.
- Ensure bond coat is compatible with waterproofing membrane.
- Manufacturers' recommendations must be followed.

#### OTHER CONSIDERATIONS

- Drains should be designed to permit drainage of water at the tile surface and the surface of the waterproofing membrane. For drainage see Detail 326DR-2025. A drainage layer may be incorporated over the waterproofing membrane as recommended by the manufacturer if a traditional double weep hole drain is used.
- When using a shower pan, a waterproof membrane is recommended below bond coat.
- Tile should be moisture resistant. Type MR1 or some MR2. Refer to page 7.
- For high use showers (hotels, gang showers, sports facilities, etc.) a waterproofing membrane shall be used.\*
- Waterproofing membrane if required must be specified. (ANSI A118.10) Follow manufacturer's recommendations.
- If waterproofing membrane is not used a vapor retarder must be used behind the mortar bed or solid backing.
- All openings and cuts must be treated to ensure waterproofing integrity.
- Refer to Notes For The Professional and 301MJ-2025.
- If waterproofing membrane is not specified a slurry bond coat must be applied to concrete slab.
- Solid backing must be suitable for a wet environment.
- Plywood even if exterior grade is not recommended for wet areas on walls due to potential warpage from humidity and seasonal changes.

\* If the shower is high use or is actually a steam shower, and the waterproofing membrane is acting as both the waterproofing membrane and the vapor retarder the waterproofing membrane must have a perm rating of .5 or less using ASTM E96 Procedure E with 90 % humidity. If the waterproofing membrane has a perm rating higher than .5 then a vapor retarder should be used behind the solid backing that has a perm rating 1.0 or less when tested with ASTM E96 Procedure A.

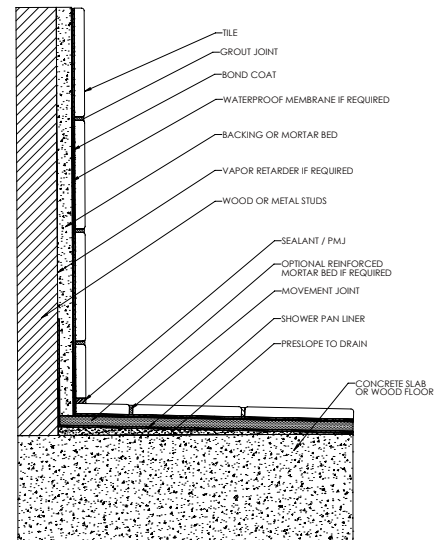

Continued

# TILE ON SHOWER RECEPTORS 319SR-2025

## DETAIL B – THIN-SET ON BACKER UNIT/BOARD

### SUITABLE SUBSTRATES

- Wood or metal studs, maximum 406 mm o.c.
- Shower pan or waterproofing membrane over structural base
- Wall constructed in accordance with Details 305W-2025 Detail A or B.

### MATERIALS

- Cementitious backer unit (ANSI A118.9) or nominal 11 mm thick fibre-cement backer board meeting ASTM C1288 or coated glass mat backer board (ASTM C1178) – minimum 13 mm thick.
- TILE – meeting ANSI A137.1, A137.2, A137.3, and for areas of use as recommended by the tile manufacturer
- SHOWER PAN – a membrane installed over sloped base.
- PREFABRICATED SHOWER PAN - minimum compressive strength .24 N/mm<sup>2</sup>.
- MORTAR BED – minimum of 32 mm to 51 mm sloped drain. See Tile Guide Specification Section Mixes 2.9.2.5.
- TAPE – 51 mm wide fibre-mesh tape.
- BOND COAT – Single or two component liquid latex-Portland cement mortar (minimum acceptable standard ANSI A118.4 or ISO 13007 C2S1).
- GROUT – Portland cement or latex-Portland cement (minimum acceptable standard ANSI A118.6 or ISO 13007 CG1), epoxy grout (minimum acceptable standard ANSI A118.3 or ISO 13007 RG).

### APPLICATION

- Attach backer unit or coated glass mat backer board to studs with rust resistant screws or nails. Fasteners shall be spaced 150 mm o.c. Backer unit must be stable, plumb and square with coated grey side of coated glass mat backer board away from the studs. Drive fasteners flush with coated surface. Do not countersink. Surface variation in the backing not to exceed 6 mm in 3000 mm or 2 mm in 300 mm and can be applied either parallel or perpendicular to framing. For large format tile where any side is greater than 380 mm surface variation should not exceed 3 mm in 3000 mm and 1.5 mm in 600 mm. Apply levelling coat, if required. All joints and angles must be taped with alkali-resistant 51 mm fibre-mesh tape, filled with a latex- Portland cement mortar and sanded. Do not sand coated glass mat backer board. For all joints and angles embed an alkali-resistant 51 mm wide fibre-mesh tape in the same bond coat material used to set the tiles and let dry. Apply thin-set bond coat to cementitious backer unit (CBU) or coated glass mat backer board using proper notched trowel to ensure adequate bond. With pressure, apply a coat of mortar by using the trowel's flat side to key the mortar into the substrate. Apply additional mortar, combing it in a single direction parallel to the tile's shortest dimension, with the trowel's notched side. Place the tiles firmly into the wet bond coat. Push the tiles back and forth in a direction perpendicular to trowel lines, to collapse the mortar ridges and to help achieve maximum coverage. Ensure proper contact between mortar, tile and substrate by periodically lifting a few tiles to check for acceptable coverage. Use sufficient bond coat to ensure minimum 95% contact with back of tile tile (it may be necessary to back-butter the tile in order to meet this requirement). Beat mosaic tile into position. Remove excess mortar from the joint areas so that at least 2/3 of the tile depth is available for grouting. Allow bond coat to cure. Force grout into the joints with a rubber grout float. Make sure all joints are well-compacted and free of voids and gaps. Remove excess grout from the tile surface and clean.

### LIMITATIONS

- Manufacturer's recommendations must be followed. Coated glass mat backer board should not be used where prolonged exposure to heat exceeds 52°C and not to be used for exterior use. It is not recommended for use with passive solar heat systems. Maximum tile size is 356 mm x 356 mm x 10 mm. Do not apply directly over concrete or masonry block.
- Coated glass mat backer board should not be used in shower floors.

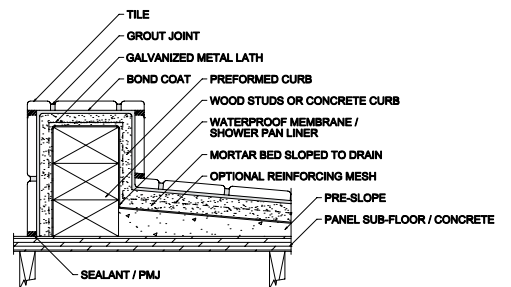
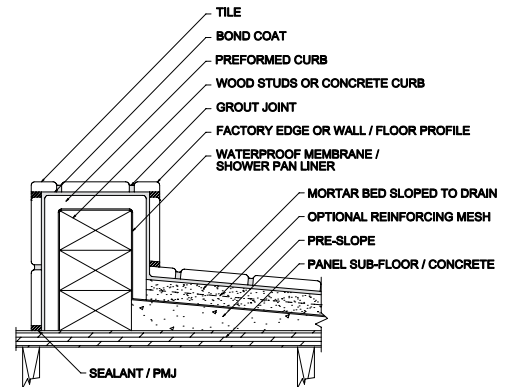
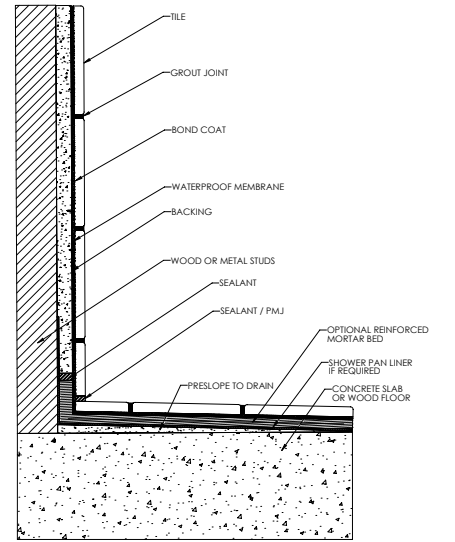

OTHER CONSIDERATIONS

- Movement joints, spacing and minimum gauge of steel studs as per instructions of manufacturer of cementitious backer board (CBU) or coated glass mat backer board.
- Provide 6 mm in 300 mm slope to drain in floor. Carry membrane or pan at least 75 mm above shower curb, or 150 mm above floor in showers without curbs. Latex additive use in place of water is recommended for Portland cement bond coat and may be used in modification of mortar bed.
- Drains should be designed to permit drainage of water at the tile surface and the surface of the waterproofing membrane. For drainage see Detail 326DR-2025. A drainage layer may be incorporated over the waterproofing membrane as recommended by the manufacturer if a traditional double weep hole drain is used.
- When using a shower pan, a waterproofing membrane is recommended below bond coat.
- Tile should be moisture resistant. Type MR1 or some MR2. Refer to page 7.
- For high use showers (hotels, gang showers, sports facilities, etc.) a waterproofing membrane shall be used over cementitious backer unit (CBU).\*
- Waterproofing membrane if required must be specified. (ANSI A118.10) Follow manufacturer's recommendations. The waterproofing membrane should be installed at least to the shower-head or preferably to the ceiling.
- All openings and cuts must be treated to ensure waterproof integrity.
- Refer to Notes For The Professional and 301MJ-2025.
- A waterproofing membrane or vapour retarder not to be used behind coated glass mat backer board.
- If waterproofing membrane is not specified a slurry bond coat must be applied to concrete slab.
- Vapour retarder must be used when recommended by manufacturer.
- Plywood even if exterior grade is not recommended for wet areas on walls due to potential warpage from humidity and seasonal changes.
- All horizontal surfaces including: seats , curbs, pony-wall, window ledges and shampoo shelves need to be sloped to drain assembly.
- A water/flood test is strongly recommended before setting tile to verify a successful installation. Wait 24 hours minimum after the membrane installation is complete to allow for final set of thin-set mortar and ensure waterproof performance at seams and connections.

\* If the shower is high use or is actually a steam shower, and the waterproofing membrane is acting as both the waterproofing membrane and the vapor retarder the waterproofing membrane must have a perm rating of .5 or less using ASTM E96 Procedure E with 90 % humidity. If the waterproofing membrane has a perm rating higher then .5 then a vapor retarder should be used behind the solid backing that has a perm rating 1.0 or less when tested with ASTM E96 Procedure A.

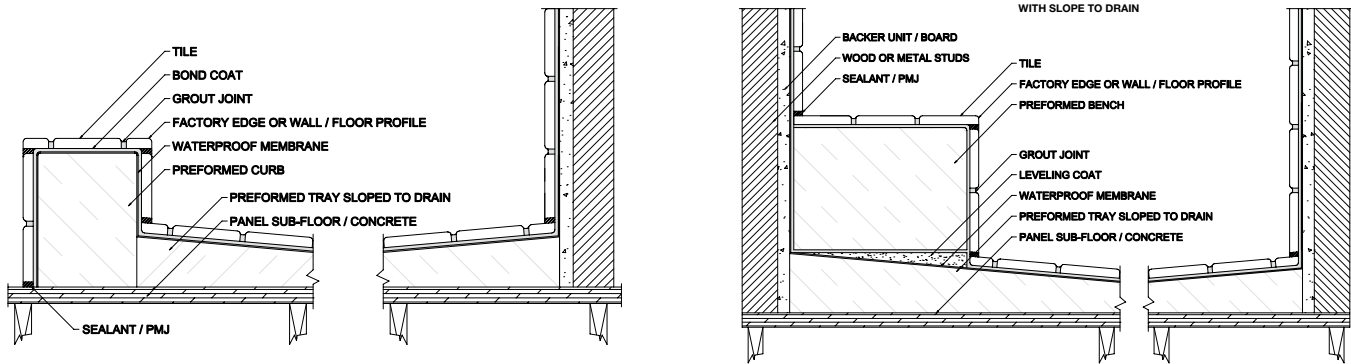

# TILE ON SHOWER RECEPTORS

## 319 SR/BF/C-2025

### DETAIL A – CURBLESS/BARRIER-FREE SHOWER CONSTRUCTION ON RECESSED CONCRETE SLAB

#### SUITABLE SUBSTRATES

- Wood or metal studs, maximum 406 mm o.c.
- Waterproofing membrane over structural base.
- Wall constructed in accordance with Details 305W-2025 Detail A or B.

#### MATERIALS

- Cementitious backer unit (ANSI A118.9) or nominal 11 mm thick fibre-cement backer board meeting ASTM C1288 or coated glass mat backer board (ASTMC1178) – minimum 13 mm thick.
- TILE – meeting ANSI A137.1, A137.2, A137.3, and for areas of use as recommended by the tile manufacturer
- DRAIN - With integrated bonding flange complying with CSA B-79-94.
- MORTAR BED – minimum of 32 mm to 51 mm sloped drain. See Tile Guide Specification Section Mixes 2.9.2.5.
- TAPE – 51 mm wide fibre-mesh tape.
- BOND COAT – Single or two component liquid latex-Portland cement mortar (minimum acceptable standard ANSI A118.4 or ISO 13007 C2S1).
- GROUT – Portland cement or latex-Portland cement (minimum acceptable standard ANSI A118.6 or ISO 13007 CG1), epoxy grout (minimum acceptable standard ANSI A118.3 or ISO 13007 RG), or RTU grout.

#### APPLICATION

- Attach backer unit or coated glass mat backer board to studs with rust resistant screws or nails. Fasteners shall be spaced 150 mm o.c. Backer unit must be table, plumb and square with coated grey side of coated glass mat backer board away from the studs. Drive fasteners flush with coated surface. Do not countersink. Surface variation in the backing not to exceed 6 mm in 3000 mm or 2 mm in 300 mm and can be applied either parallel or perpendicular to framing. For large format tile where any side is greater than 380 mm, surface variation should not exceed 3 mm in 3000 mm and 1.5 mm in 600 mm. Apply levelling coat, if required. All joints and angles must be taped with alkali-resistant 51 mm fibre-mesh tape, filled with a latex-Portland cement mortar and sanded. Do not sand coated glass mat backer board. For all joints and angles embed an alkali-resistant 51 mm wide fibre-mesh tape in the same bond coat material used to set the tiles and let dry. Use proper notched trowel to ensure adequate bond. With pressure, apply a coat of mortar by using the trowel's flat side to key the mortar into the substrate. Apply additional mortar, combing it in a single direction parallel to the tile's shortest dimension, with the trowel's notched side. Place the tiles firmly into the wet bond coat. Push the tiles back and forth in a direction perpendicular to trowel lines, to collapse the mortar ridges and to help achieve maximum coverage. Ensure proper contact between mortar, tile and substrate by periodically lifting a few tiles to check for acceptable coverage. Use sufficient bond coat to ensure minimum 95% contact with back of tile (it may be necessary to back-butter the tile in order to meet this requirement.. Beat mosaic tile into position. Remove excess mortar from the joint areas so that at least 2/3 of the tile depth is available for grouting. Allow bond coat to cure. Force grout into the joints with a rubber grout float. Make sure all joints are well-compacted and free of voids and gaps. Remove excess grout from the tile surface and clean.

#### LIMITATIONS

- Manufacturer's recommendations must be followed. Coated glass mat backerboard should not be used where prolonged exposure to heat exceeds 52°C and not to be used for exterior use. It is not recommended for use with passive solar heat systems. Maximum tile size is 356 mm x 356 mm x 10 mm. Do not apply directly over concrete or masonry block.

- Coated glass mat backer board should not be used in shower floors.
- OTHER CONSIDERATIONS
- Movement joints, spacing and minimum gauge of steel studs as per instructions of manufacturer of cementitious backer board (CBU) or coated glass mat backer board.
- Provide 6 mm in 300 mm slope to drain in floor. Carry membrane or pan at least 75 mm above shower curb, or 150 mm above floor in showers without curbs. Latex additive use in place of water is recommended for Portland cement bond coat and may be used in modification of mortar bed.
- Drains should be designed to permit drainage of water at the tile surface and the surface of the waterproofing membrane. For drainage see Detail 326DR-2025.
- For high use showers (hotels, gang showers, sports facilities, etc.) a waterproofing membrane shall be used over cementitious backer unit (CBU).\*
- Waterproofing membrane (ANSI A118.10), follow manufacturer's recommendations.
- The waterproofing membrane should be installed at least to the shower-head or preferably to the ceiling.
- All openings and cuts must be treated to ensure waterproof integrity.
- Refer to Notes For The Professional and 301MJ-2025.
- A waterproof membrane or vapour retarder not to be used behind coated glass-mat backer board.
- Vapour retarder must be used when recommended by manufacturer.
- Plywood even if exterior grade is not recommended for wet areas on walls dueto potential warpage from humidity and seasonal changes.
- All horizontal surfaces including: seats, curbs, pony-wall, window ledges and shampoo shelves need to be sloped to drain assembly.
- A prefabricated shower tray may be used as an alternative to the mortar bed Minimum compressive strength .24 N/mm<sup>2</sup>.
- A water/flood test is strongly recommended before setting tile to verify a successful installation. Wait 24 hours minimum after the membrane installation is complete to allow for final set of thin-set mortar and ensure waterproof performance at seams and connections.

\*If the shower is high use or is actually a steam shower, and the waterproofing membrane is acting as both the waterproofing membrane and the vapor retarder the waterproofing membrane must have a perm rating of .5 or less using ASTM E96 Procedure E with 90% humidity. If the waterproofing membrane has a perm rating higher then .5 then a vapor retarder should be used behind the solid backing that has a perm rating 1.0 or less when tested with ASTM E96 Procedure A.

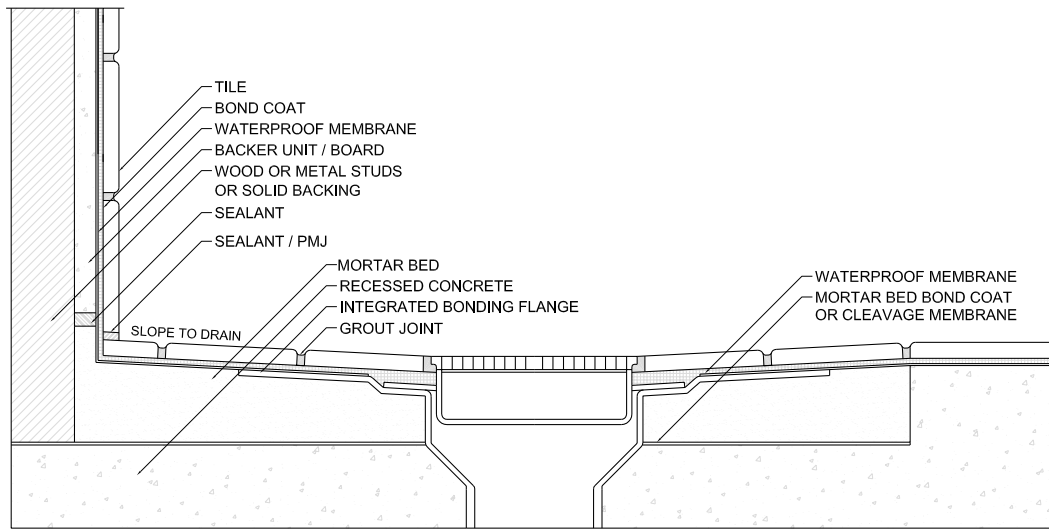

# TILE ON SHOWER RECEPTORS

## 319 SR/BF/C-2025

### DETAIL B – CURBLESS/BARRIER-FREE SHOWER CONSTRUCTION ON WOOD-FRAME CONSTRUCTION

#### SUITABLE SUBSTRATES

- Interior showers with curbless access.
- Over wood subfloors. See the Base information under Requirements (below) for details.
- Wood or metal studs, maximum 406 mm o.c.
- Waterproofing membrane over structural base
- Wall constructed in accordance with Details 305W-2025 Detail A or B.

#### MATERIALS

- Cementitious backer unit (ANSI A118.9) or nominal 11 mm thick fibre-cement backer board meeting ASTM C1288 or coated glass mat backer board (ASTM C1178) –minimum 13 mm-thick.
- TILE – meeting ANSI A137.1, A137.2, A137.3, and for areas of use as recommended by the tile manufacturer
- DRAIN - With integrated bonding flange complying with CSA B-79-94.
- MORTAR BED – minimum of 32 mm to 51 mm sloped drain. See Tile Guide Specification Section Mixes 2.9.2.5.
- TAPE – 51 mm wide fibre-mesh tape.
- Prefabricated Sloped Tray - minimum compressive strength .24 N/mm<sup>2</sup>.
- BOND COAT – Single or two component liquid latex-Portland cement mortar (minimum acceptable standard ANSI A118.4 or ISO 13007 C2S1).
- GROUT – Portland cement or latex-Portland cement (minimum acceptable standard ANSI A118.6 or ISO 13007 CG1), epoxy grout (minimum acceptable standard ANSI A118.3 or ISO 13007 RG), or RTU grout.

#### APPLICATION

- Attach backer unit or coated glass mat backer board to studs with rust resistant screws or nails. Fasteners shall be spaced 150 mm o.c. Backer unit must be table, plumb and square with coated grey side of coated glass mat backer board away from the studs. Drive fasteners flush with coated surface. Do not countersink. Surface variation in the backing not to exceed 6 mm in 3000 mm or 2 mm in 300 mm and can be applied either parallel or perpendicular to framing. For large format tile where any side is greater than 380 mm, surface variation should not exceed 3 mm in 3000 mm and 1.5 mm in 600 mm. Apply levelling coat, if required. All joints and angles must be taped with alkali-resistant 51 mm fibre-mesh tape, filled with a latex- Portland cement mortar and sanded. Do not sand coated glass mat backer board. For all joints and angles embed an alkali-resistant 51 mm wide fibre-mesh tape in the same bond coat material used to set the tiles and let dry. Use proper notched trowel to ensure adequate bond. With pressure, apply a coat of mortar by using the trowel's flat side to key the mortar into the substrate. Apply additional mortar, combing it in a single direction parallel to the tile's shortest dimension, with the trowel's notched side. Place the tiles firmly into the wet bond coat. Push the tiles back and forth in a direction perpendicular to trowel lines, to collapse the mortar ridges and to help achieve maximum coverage. Ensure proper contact between mortar, tile and substrate by periodically lifting a few tiles to check for acceptable coverage. Use sufficient bond coat to ensure minimum 95% contact with back of tile (it may be necessary to back-butter the tile in order to meet this requirement.. Beat mosaic tile into position. Remove excess mortar from the joint areas so that at least 2/3 of the tile depth is available for grouting. Allow bond coat to cure. Force grout into the joints with a rubber grout float. Make sure all joints are well-compacted and free of voids and gaps. Remove excess grout from the tile surface and clean.

#### LIMITATIONS

- Manufacturer's recommendations must be followed. Coated glass mat backerboard should not be used where prolonged exposure to heat exceeds 52° C and not to be used for exterior use. It is not recommended for use with passive solar heat systems. Maximum tile size is 356 mm x 356 mm x 10 mm. Do not apply directly over concrete or masonry block.
- Coated glass mat backer board should not be used in shower floors.

#### OTHER CONSIDERATIONS

- Movement joints, spacing and minimum gauge of steel studs as per instructions of manufacturer of cementitious backer board (CBU) or coated glass mat backer board.
- Recessing the floor of a bathroom must be done in a way that preserves the structural integrity and safety of the construction. This may require the services of a qualified design professional (e.g., architect, engineer, etc.).
- Curbless tiled showers rely on the slope of the floor to effectively contain water in the immediate shower area and direct water to the drain. Given the wide range of potential configurations, it isn't possible to address them all in this manual.
- Waterproofing must be installed in all areas subject to water exposure. Install waterproofing membrane over mortar beds.

A water/flood test is strongly recommended before setting tile to verify a successful installation. Wait 24 hours minimum after the membrane installation is complete to allow for final set of thin-set mortar and ensure waterproof performance at seams and connections. Refer to local plumbing codes for any specific requirements in your area. For curbless showers a temporary dam (e.g., a 2x4 and silicone sealant, plastic sheeting and sand, etc.) must be provided at the threshold to perform the water test.

Drains should be designed to permit drainage of water at the tile surface and the surface of the waterproofing membrane. For drainage see Detail 326DR-2025.

- For high use showers (hotels, gang showers, sports facilities, etc.) a waterproofing membrane shall be used over cementitious backer unit (CBU).\*
- Waterproofing membrane (ANSI A118.10), follow manufacturer's recommendations.
- The waterproof membrane should be installed at least to the shower-head or preferably to the ceiling.
- All openings and cuts must be treated to ensure waterproof integrity.
- Refer to Notes For The Professional and 301MJ-2025.
- A waterproofing membrane or vapour retarder not to be used behind coated glass-mat backer board.
- Vapour retarder must be used when recommended by manufacturer.
- Plywood even if exterior grade is not recommended for wet areas on walls due to potential warpage from humidity and seasonal changes.
- All horizontal surfaces including: seats, curbs, pony-wall, window ledges and shampoo shelves need to be sloped to drain assembly.

\*If the shower is high use or is actually a steam shower, and the waterproofing membrane is acting as both the waterproofing membrane and the vapor retarder the waterproofing membrane must have a perm rating of .5 or less using ASTM E96 Procedure E with 90 % humidity. If the waterproofing membrane has a perm rating higher than .5 then a vapor retarder should be used behind the solid backing that has a perm rating 1.0 or less when tested with ASTM E96 Procedure A.

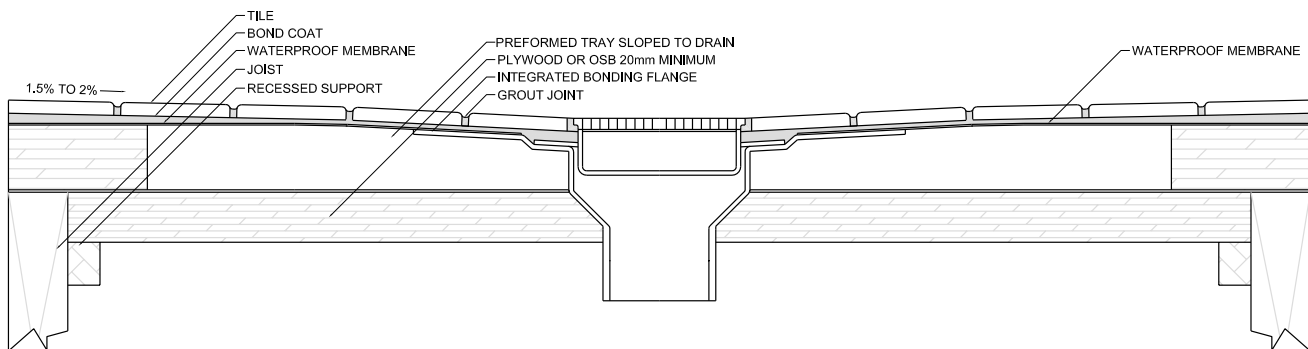

# TILE OVER INSULATION IN REFRIGERATION ROOMS 320R-2025



Please refer to page 7.

## DETAIL A – ON MORTAR BED

### SUITABLE SUBSTRATES

- Block-type insulation with acceptable compressive strength over masonry or concrete walls.

### MATERIALS

- TILE – meeting ANSI A137.1, A137.2, A137.3, and for areas of use as recommended by the tile manufacturer
- GALVANIZED METAL LATH – 1.4 kg/m<sup>2</sup> (ASTM C847).
- BOND COAT – Single or two component liquid latex-Portland cement mortar (minimum acceptable standard ANSI A118.4 or ISO 13007 C2S1).
- GROUT – Portland cement or latex-Portland cement (minimum acceptable standard ANSI A118.6 or ISO 13007 CG1), epoxy grout (minimum acceptable standard ANSI A118.3 or ISO 13007 RG).

### APPLICATION

- Attach backer unit or coated glass mat backer board to studs with rust resistant screws or nails. Fasteners shall be spaced 150 mm o.c. Backer unit must be table, plumb and square with coated grey side of coated glass mat backer board away from the studs. Drive fasteners flush with coated surface. Do not countersink. Surface variation in the backing not to exceed 6 mm in 3000 mm or 2 mm in 300 mm and can be applied either parallel or perpendicular to framing. For large format tile where any side is greater than 380 mm, surface variation should not exceed 3 mm in 3000 mm and 1.5 mm in 600 mm. Apply levelling coat, if required. All joints and angles must be taped with alkali-resistant 51 mm fibre-mesh tape, filled with a latex-Portland cement mortar and sanded. Do not sand coated glass mat backer board. For all joints and angles embed analkali-resistant 51 mm wide fibre-mesh tape in the same bond coat material used to set the tiles and let dry. Use proper notched trowel to ensure adequate bond. With pressure, apply a coat of mortar by using the trowel's flat side to key the mortar into the substrate. Apply additional mortar, combing it in a single direction parallel to the tile's shortest dimension, with the trowel's notched side. Place the tiles firmly into the wet bond coat. Push the tiles back and forth in a direction perpendicular to trowel lines, to collapse the mortar ridges and to help achieve maximum coverage. Ensure proper contact between mortar, tile and substrate by periodically lifting a few tiles to check for acceptable coverage. Use sufficient bond coat to ensure minimum 95% contact with back of tile (it may be necessary to back-butter the tile in order to meet this requirement.. Beat mosaic tile into position. Remove excess mortar from the joint areas so that at least 2/3 of the tile depth is available for grouting. Allow bond coat to cure. Force grout into the joints with a rubber grout float. Make sure all joints are well-compacted and free of voids and gaps. Remove excess grout from the tile surface and clean.

### OTHER CONSIDERATIONS

- Design of vapour retarder and reinforced concrete slab by others. Floor should be sloped 20 mm per 1000 mm. Provide drains as required. Latex additive use in place of water is recommended for Portland cement bond coat, and may be used in modification of mortar bed.
- Drains should be designed to permit drainage of water at the tile surface and the surface of the waterproofing membrane. A drainage layer may be incorporated over the waterproofing membrane as recommended by the manufacturer. For drainage see Detail 326DR-2025.
- Refer to Notes For The Professional and 301MJ-2025.
- For thin-set applications over backer units refer to Detail B.
- Refer to Detail 319SR-2025 Detail B for drain.
- If a waterproofing membrane is required – See Detail B.
- For heavy vehicular traffic, confirm compressive strength of insulation by manufacturer.

Continued

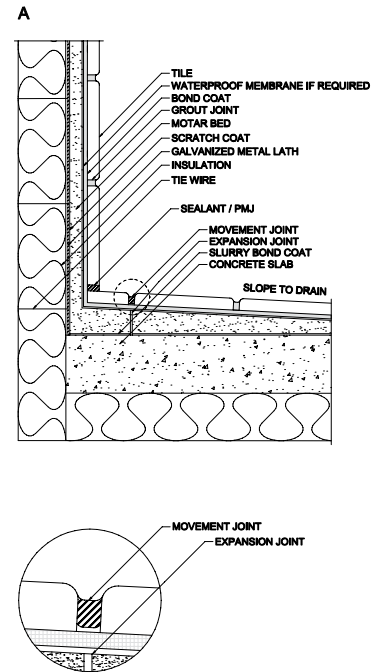

# TILE OVER INSULATION IN REFRIGERATION ROOMS 320R-2025



Please refer to page 7.

## DETAIL B – THIN-SET ON CEMENTITIOUS BACKER UNIT (CBU)

### SUITABLE SUBSTRATES

- On solid backing block-type insulation with acceptable compressive strength.

### MATERIALS

- Cementitious backer unit (CBU) (ANSI A118.9) or nominal 11 mm-thick fibre-cement backer board meeting ASTM C1288).
- TILE – meeting ANSI A137.1, A137.2, A137.3, and for areas of use as recommended by the tile manufacturer
- GALVANIZED TIE WIRE – on 300 mm o.c. through insulation for fastening to backing.
- Rigid polystyrene insulation CAN/ULC 5701 Type A.
- BOND COAT – Single or two component liquid latex-Portland cement mortar (minimum acceptable standard ANSI A118.4 or ISO 13007 C2S1).
- GROUT – Portland cement or latex-Portland cement (minimum acceptable standard ANSI A118.6 or ISO 13007 CG1), epoxy grout (minimum acceptable standard ANSI A118.3 or ISO 13007 RG).

### APPLICATION

- Cementitious backer unit (CBU) must be stable, plumb, square and tied to backing. Surface variation not to exceed 6 mm in 3000 mm or 2 mm in 300 mm. For large format tile where any side is greater than 380 mm, surface variation should not exceed 3 mm in 3000 mm and 1.5 mm in 600 mm. For tile with any edge longer than 380 mm use sufficient bond coat to ensure minimum 95% contact, with the corners and edges fully supported. Apply levelling coat if required. All joints must be taped with 51 mm fibre-mesh tape, filled with a dry-set or latex mortar and sanded. Apply thin-set bond coat to cementitious backer unit (CBU), fibre cement backer board using proper notched trowel. With pressure, apply a coat of mortar by using the trowel's flat side to key the mortar into the substrate. Apply additional mortar, combing it in a single direction parallel to the tile's shortest dimension, with the trowel's notched side. Place the tiles firmly into the wet bond coat. Push the tiles back and forth in a direction perpendicular to trowel lines, to collapse the mortar ridges and to help achieve maximum coverage. Ensure proper contact between mortar, tile and substrate by periodically lifting a few tiles to check for acceptable coverage. Use sufficient bond coat to ensure minimum 95% contact with back of tile (it may be necessary to back-butter the tile in order to meet this requirement). Beat mosaic tile into position. Remove excess mortar from the joint areas so that at least 2/3 of the tile depth is available for grouting. Allow bond coat to cure. Force grout into the joints with a rubber grout float. Make sure all joints are well-compacted and free of voids and gaps. Remove excess grout from the tile surface and clean.

### OTHER CONSIDERATIONS

- Design of vapour retarder and reinforced concrete slab by others. Floor should be sloped 20 mm per 1000 mm. Provide drains as required. Latex additive use in place of water is recommended for Portland cement bond coat and may be used in modification of mortar bed.
- Drains should be designed to permit drainage of water at the tile surface and the surface of the waterproofing membrane. A drainage layer may be incorporated over the waterproofing membrane as recommended by the manufacturer. For drainage see Detail 326DR-2025.
- Refer to Notes For The Professional and 301MJ-2025.
- Refer to Detail 319SR-2025 Detail B for drain.
- Waterproofing membrane if required must be specified. (ANSI A118.10) Follow manufacturer's recommendations.
- If waterproofing membrane is not specified, a slurry bond coat must be applied to concrete slab.
- For heavy vehicular traffic, confirm compressive strength of insulation by manufacturer.

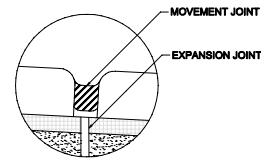
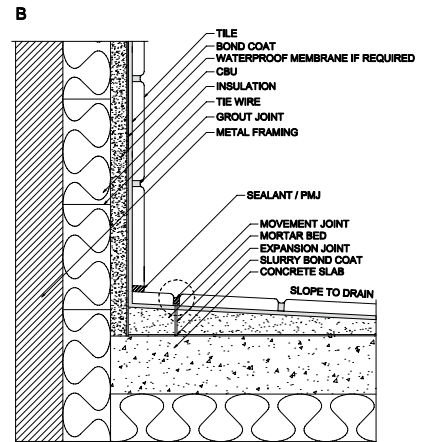

# TILE INSTALLED IN STEAM ROOMS

## 321SR-2025



Please refer to page 7.

### DETAIL A – CONCRETE OR MASONRY CONSTRUCTION

#### SUITABLE SUBSTRATES

- Frame construction, masonry or concrete backing.

#### MATERIALS

- TILE – meeting ANSI A137.1, A137.2, A137.3, and for areas of use as recommended by the tile manufacturer
- MORTAR BED AND BOND COAT – Single or two component liquid latex-Portland cement mortar (minimum acceptable standard ANSI A118.4 or ISO 13007 C2S1).
- GROUT – per manufacturer’s recommendations.

#### APPLICATION

- Tie wire spaced at 300 mm vertically and 406 mm to 600 mm horizontally. Attach to 6 mm steel pencil rods vertically over insulation; attach metal lath to pencil rods. Install scratch coat (see Tile Guide Specification Section Mixes 2.9.2.1), mortar bed (see Tile Guide Specification Section Mixes 2.9.2.3 and 2.9.2.5) and bond coat as per detail 307W-2025 or 308W-2025 (walls), Detail 310F-2025 A (floors) and 315C-2025 (ceilings).

#### LIMITATIONS

- Waterproofing membrane must be suitable for operating temperatures.

#### OTHER CONSIDERATIONS

- Detail 311F-2025 may be used for floor installation provided that proper slope to drain is in the substrate.
- Drains should be designed to permit drainage of water at the tile surface and the surface of the waterproofing membrane. A drainage layer may be incorporated over the waterproofing membrane as recommended by the manufacturer. For drainage see Detail 326DR-2025.
- Refer to Notes For The Professional and 301MJ-2025.
- For high use showers and wet areas (hotels, gang showers, sports facilities etc.) a waterproofing membrane shall be used.\*
- All openings and cuts must be treated to ensure waterproof integrity.
- Refer to Detail 319B-2025 for drainage detail.
- If waterproofing membrane is not specified a slurry bond coat must be applied to concrete slab.
- Slope ceilings 150 mm per 1000 mm and floors 20 mm per 1000 mm.
- Considering that tile installation in Steam Rooms are very detailed. The installation shall be performed by skilled mechanics trained and experienced intile work with a minimum of five years of proven experience in projects of similar size and scope. If requested by Consultant, installer shall provide a listing of previously completed projects of similar size and scope. If using Natural Stone consult manufacturer or supplier for suitability.
- A water test is strongly recommended before setting tile to verify a successful installation. Wait 24 hours minimum after the membrane installation is complete to allow for final set of thin-set mortar and ensure waterproof performance at seams and connections.

\* For continuous steamrooms if the waterproofing membrane is acting as both the waterproofing membrane and the vapor retarder the waterproofing membrane must have a perm rating of .5 or less using ASTM E96 Procedure E with 90 % humidity. If the waterproofing membrane has a perm rating higher than .5 then a vapor retarder should be used that has a perm rating 1.0 or less when tested with ASTM E96 Procedure A.

Continued

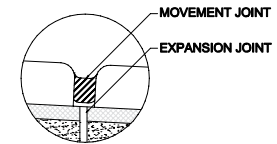
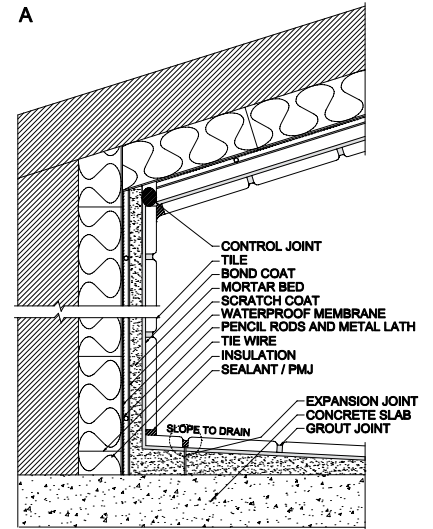

# TILE INSTALLED IN STEAM ROOMS

## 321SR-2025



Please refer to page 7.

### DETAIL B – FRAME CONSTRUCTION

#### SUITABLE SUBSTRATES

- Wood or metal studs maximum 406 mm o.c.

#### MATERIALS

- 13 mm minimum thickness cementitious backer unit (CBU).
- MORTAR BED AND BOND COAT – Single or two component liquid latex-Portland cement mortar (minimum acceptable standard ANSI A118.4 or ISO 13007 C2S1).
- GROUT – per manufacturer's recommendations.
- VAPOUR RETARDER – per manufacturer's recommendations.

#### APPLICATION

- If tile being installed directly: use Detail 305W-2025 Detail A on walls;
- if tile is being set over a waterproofing membrane follow manufacturer's recommendations.

#### OTHER CONSIDERATIONS

- Detail 311F-2025 may be used provided that proper slope to drain is in the substrate.
- Drains should be designed to permit drainage of water at the tile surface and the surface of the waterproofing membrane. A drainage layer may be incorporated over the waterproofing membrane as recommended by the manufacturer. For drainage see Detail 326DR-2025.
- Refer to Notes For The Professional and 301MJ-2025.
- For high use showers and wet areas (hotels, gang showers, sports facilities etc.) a waterproof membrane shall be used.\*
- All openings and cuts must be treated to ensure waterproof integrity.
- Refer to Detail 319SR-2025 Detail B for drain.
- Waterproofing membrane if required must be specified. (ANSI A118.10) Follow manufacturer's recommendations.
- If waterproofing membrane is not specified a slurry bond coat must be applied to concrete slab.
- If required, an insulation layer should be used made of rigid polystyrene. Consult with manufacturer.
- Slope ceilings 150 mm per 1000 mm and floors 20 mm per 1000 mm.
- Considering that tile installation in Steam Rooms are very detailed. The installation shall be performed by skilled mechanics trained and experienced in tile work with a minimum of five years of proven experience in projects of similar size and scope. If requested by Consultant, installer shall provide a listing of previously completed projects of similar size and scope.
- A water test is strongly recommended before setting tile to verify a successful installation. Wait 24 hours minimum after the membrane installation is complete to allow for final set of thin-set mortar and ensure waterproof performance at seams and connections.

\* For continuous steamrooms if the waterproofing membrane is acting as both the waterproofing membrane and the vapor retarder the waterproofing membrane must have a perm rating of .5 or less using ASTM E96 Procedure E with 90 % humidity. If the waterproofing membrane has a perm rating higher than .5 then a vapor retarder should be used that has a perm rating 1.0 or less when tested with ASTM E96 Procedure A.

B

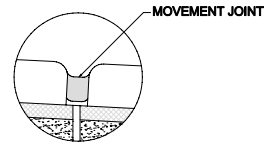
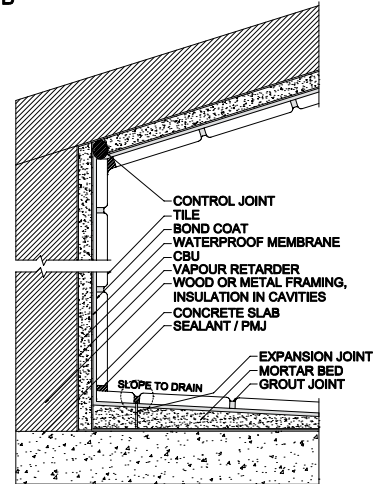

# TILE INSTALLED ON COUNTERTOPS

## 322C-2025

### SUITABLE SUBSTRATES

- 19 mm exterior grade plywood

### MATERIALS

- Extra heavy duty glazed tile, unglazed porcelain tile, natural stone tile.
- Cleavage membrane – minimum 6 mils polyethylene film (Detail C).
- METAL LATH – 1.4 kg/m<sup>2</sup> (Detail C) (ASTM C847).
- Scratch coat (see Tile Guide Specification Section Mixes 2.9.2.1) and 25+ mm mortar bed (see Tile Guide Specification Section Mixes 2.9.2.3 and 2.9.2.5) (Detail C).
- Cementitious backer unit (CBU) minimum 13 mm thick (ANSI A118.9) or coated glass mat backer board (Detail B) minimum 13 mm (ASTM C1178).
- BOND COAT – Epoxy (minimum acceptable standard ANSI 118.3 or ISO 13007 R1), latex-Portland cement mortar (minimum acceptable standard ANSI A118.4 or ISO 13007 C2S1P1) (Detail A & B). Latex-Portland cement mortar on cured mortar bed (Detail C).
- GROUT – Latex-Portland cement (minimum acceptable standard ANSI A118.6 or ISO 13007 CG1) with a water base sealer or epoxy grout (minimum acceptable standard ANSI A118.3 or ISO 13007 RG).

### APPLICATION

- Detail A - Gap plywood 6 mm and support joint with cross bridging. Fill gap between plywood with setting materials. Random cuts spaced approximately at 150 mm and 150 mm in length should be cut into the plywood to relieve the strains and to permit the plywood to remain relatively equal in moisture content on both sides.
- Detail B - Attach cementitious backer unit (CBU) or nominal 11 mm thick fibre-cement backer meeting ASTM C1288. For coated glass mat backer board do not use membrane and install with 30 mm galvanized or non-pull out nails. Gap cementitious backer unit (CBU) 3 mm. Tape joint with fiberglass tape set in latex-Portland cement mortar. Set tiles to achieve minimum 95% contact with bonding materials (it may be necessary to back-butter the tile in order to meet this requirement) and let cure before grouting. Provide 100% contact with bonding material under bullnose tile at the apron.
- Detail C - Apply polyethylene film over lapped at least 100 mm. Nail galvanized diamond metal lath butted, not overlapped, to the plywood. Apply mortar bed to required thickness of 32 mm min. Allow mortar bed to cure. Apply bond coat to cured mortar bed. Use proper notched trowel to ensure adequate bond. With pressure, apply a coat of mortar by using the trowel's flat side to key the mortar into the substrate. Apply additional mortar, combing it in a single direction parallel to the tile's shortest dimension, with the trowel's notched side. Place the tiles firmly into the wet bond coat. Push the tiles back and forth in a direction perpendicular to trowel lines, to collapse the mortar ridges and to help achieve maximum coverage. Ensure proper contact between mortar, tile and substrate by periodically lifting a few tiles to check for acceptable coverage. Use sufficient bond coat to ensure minimum 95% contact with back of tile (it may be necessary to back-butter the tile in order to meet this requirement). Beat mosaic tile into position. Remove excess mortar from the joint areas so that at least 2/3 of the tile depth is available for grouting. Allow bond coat to cure. Force grout into the joints with a rubber grout float. Make sure all joints are well-compacted and free of voids and gaps. Remove excess grout from the tile surface and clean.

### LIMITATIONS

- Latex-Portland cement grouts are absorbent and can stain. A water based grout sealer may be recommended. Follow manufacturers recommendations.

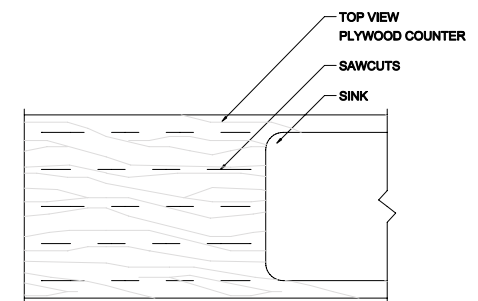
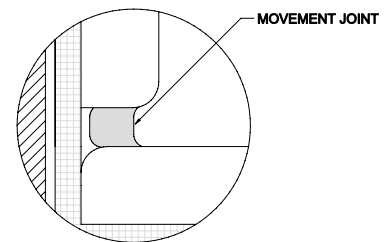
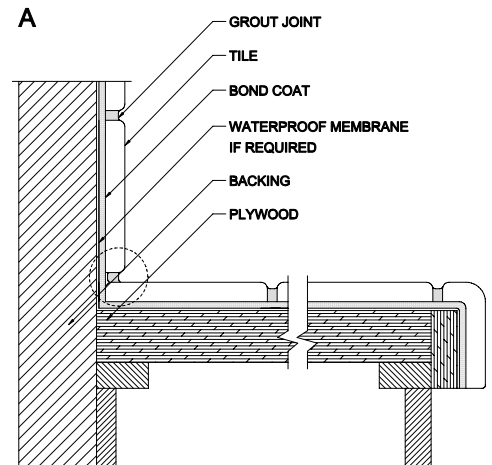

**OTHER CONSIDERATIONS**

- Details A and B are most commonly used, particularly in residential construction. Epoxy grout is recommended for optimum stain resistance and hygienic purposes. An alternate method for finishing counter top edges is the use of prefabricated trim at the apron. Where ceramic tile is used to cover apron, full support must be provided behind tile using one of the methods shown. Where cut outs in counter tops are provided for appliances, provide cross bridging under counter tops within 51 mm of opening.
- A movement joint may be provided between the backsplash and the counter. A caulking sealant or a prefabricated movement joint may be used.
- Waterproofing membrane if required must be specified. (ANSI A118.10) Follow manufacturer's recommendations.
- Refer to Notes For The Professional and 301MJ-2025.

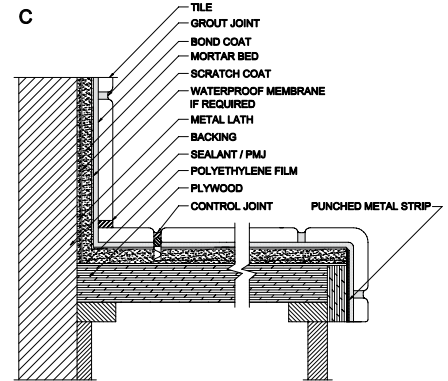
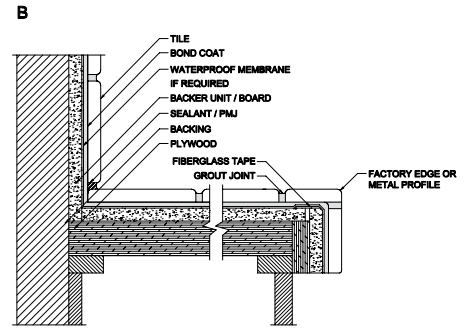

# TILE INSTALLED OVER EXISTING TILE

## 323RW-2025

### INTERIOR WALLS ONLY

#### SUITABLE SUBSTRATES

- Existing tile on frame or masonry construction where existing tile is well bonded.

#### MATERIALS

- TILE – meeting ANSI A137.1, A137.2, A137.3, and for areas of use as recommended by the tile manufacturer
- GALVANIZED METAL LATH – 1.4 kg/m<sup>2</sup> (ASTM C847).
- MULTI-PURPOSE PRIMER (optional) – latex-based bond promoting primer
- BOND COAT – Dry-set mortar (minimum acceptable standard ANSI A118.1 or ISO 13007 C1), latex-Portland cement mortar (minimum acceptable standard ANSI A118.4 or ISO 13007 C2S1), modified epoxy emulsion mortars, 100% solids epoxy mortar, epoxy adhesive (minimum acceptable standard ANSI A118.3 or ISO 13007 R1), or organic adhesives (minimum acceptable standard ANSI A118.3 or ISO 13007 R1).
- GROUT – Portland cement, latex-Portland cement (minimum acceptable standard ANSI A118.6 or ISO 13007 CG1), or epoxy grouts (minimum acceptable standard ANSI A118.3 or ISO 13007 RG).

#### PREPARATION

- Remove soap scum, sealers, dirt or other contaminants from existing tile. Mechanically abrade surfaces of existing glazed tile with a carborundum disc or by other means. Rinse abraded surface to remove dust. Apply levelling material and reinforce joint between levelling materials and existing tile with 51 mm fibre mesh tape set in latex-Portland cement mortars.
- For non-glazed or textured surfaces use an appropriate stripper as recommended by manufacturer.

#### APPLICATION

- Apply tile using latex-Portland cement mortar, epoxy or organic adhesive ANSI A136.1 Type 1 only. Organic adhesives can be used for absorbent bisquet tile. Organic adhesives require complete evaporation of water in the adhesive in order to obtain cure and are not recommended for commercial use. Refer to 304W-2019-2021 for installations with organic adhesive and Detail 305W-2019-2021 for installations using latex-Portland cement mortars or dry-set mortars. Use sufficient bond coat to ensure minimum of 95% contact on wet areas (it may be necessary to back-butter the tile in order to meet this requirement).

#### LIMITATIONS

- Acid washing will not remove wax, sealers and oils.
- For commercial use a cementitious bonding material may be more suitable than organic adhesives to obtain a higher impact resistance and to improve bond strength.
- Consult maximum tile dimensions as per organic adhesive manufacturers's literature.

#### OTHER CONSIDERATIONS

- Install new tile so that grout joint is over transition point between levelling material and existing ceramic tile where possible.
- Refer to Notes For The Professional and 301MJ-2025.
- For larger tile non sag mortars may be considered. Follow manufacturers recommendations
- Waterproofing membrane if required must be specified. (ANSI A118.10) Follow manufacturer's recommendations.

A

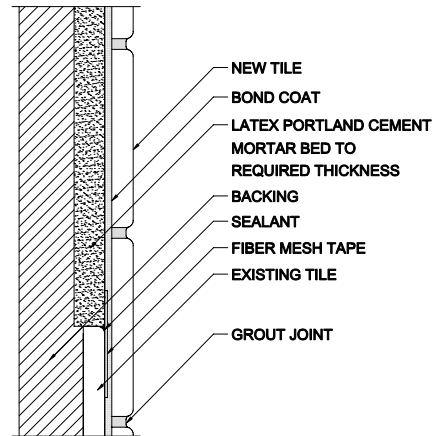

B

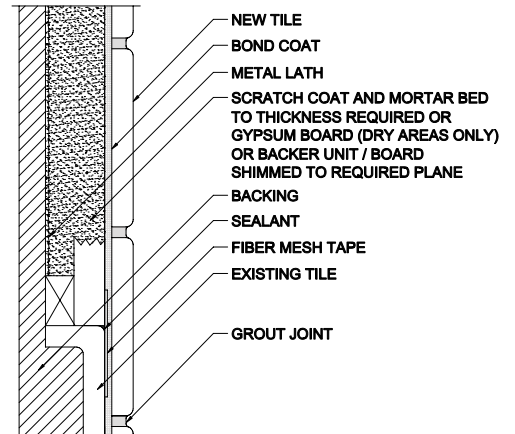

# TILE INSTALLED OVER EXISTING TILE 324RF-2025

## DETAIL A- INTERIOR FLOORS ONLY

### SUITABLE SUBSTRATES

- Existing well bonded tile, cementitious or epoxy terrazzo, marble, granite and slate, free of cracks.

### MATERIALS

- TILE – meeting ANSI A137.1, A137.2, A137.3, and for areas of use as recommended by the tile manufacturer
- MULTI-PURPOSE PRIMER (optional) – latex-based bond promoting primer.
- BOND COAT – Dry-set mortar (minimum acceptable standard ANSI A118.1 or ISO 13007 C1), latex-Portland cement mortar (minimum acceptable standard ANSI A118.4 or ISO 13007 C2S1), modified epoxy emulsion mortars, 100% solids epoxy mortar, epoxy adhesive (minimum acceptable standard ANSI A118.3 or ISO 13007 R1), or organic adhesives (minimum acceptable standard ANSI A118.3 or ISO 13007 R1).
- GROUT – Portland cement, latex-Portland cement (minimum acceptable standard ANSI A118.6 or ISO 13007 CG1), or epoxy grouts (minimum acceptable standard ANSI A118.3 or ISO 13007 RG).

### PREPARATION

- Remove soap scum, sealers, dirt or other contaminants from existing tile. Mechanically abrade surfaces of existing glazed tile with a shot blast, scarifier or by other means. Rinse abraded surface to remove dust.
- For non-glazed or textured surfaces use an appropriate stripper as recommended by the manufacturer.
- Pre-fill any voids in the existing grout joints, chipped tile and/or missing tile.

### APPLICATION

- Apply tile using single or two component liquid latex Portland cement mortar or epoxy mortar. Refer to Detail 311F-2025.

### LIMITATIONS

- Acid washing will not remove wax, sealers and oils.

### OTHER CONSIDERATIONS

- Existing installations must be sound, well bonded and free of structural cracks. If existing installation is not structurally sound, consider use of detail 309F-2025 or the use of crack isolation membrane. See Detail 311F-2025 Detail C.
- Refer to Notes For The Professional and 301MJ-2025.
- Existing movement joints must be respected and carried through to new tile work.
- Increase in height may require adjustments to threshold or the use of a prefabricated reducer profile to meet adjacent floors.

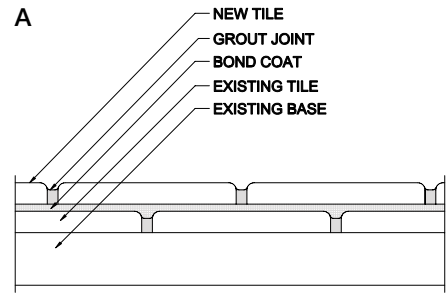

## ★ TILE INSTALLED OVER EXISTING TILE 324RF-2025

### DETAIL B – FLOWABLE HYDRAULIC CEMENT UNDERLAYMENT / SELF-LEVELING UNDERLAYMENT INTERIOR FLOORS ONLY

#### SUITABLE SUBSTRATES

- Existing well bonded tile, cementitious or epoxy terrazzo, marble, granite and slate, free of cracks.

#### MATERIALS

- TILE – meeting ANSI A137.1, A137.2, A137.3, and for areas of use as recommended by the tile manufacturer
- PRIMER – per manufacturer's recommendations
- FHCU /SLU – Meeting ANSI A118.16
- BOND COAT – Dry-set mortar (minimum acceptable standard ANSI A118.1 or ISO 13007 C1), latex-Portland cement mortar (minimum acceptable standard ANSI A118.4 or ISO 13007 C2S1), modified epoxy emulsion mortars, 100% solids epoxy mortar, epoxy adhesive (minimum acceptable standard ANSI A118.3 or ISO 13007 R1), or organic adhesives (minimum acceptable standard ANSI A118.3 or ISO 13007 R1).
- GROUT – Portland cement, latex-Portland cement (minimum acceptable standard ANSI A118.6 or ISO 13007 CG1), or epoxy grouts (minimum acceptable standard ANSI A118.3 or ISO 13007 RG).

#### PREPARATION

- Remove soap scum, sealers, dirt or other contaminants from existing tile. Mechanically abrade surfaces of existing glazed tile with a shot blast, scarifier or by other means. Rinse abraded surface to remove dust.
- For non-glazed or textured surfaces use an appropriate stripper as recommended by the manufacturer.
- Pre-fill any voids in the existing grout joints, chipped tile and/or missing tile.

#### APPLICATION

- Apply primer over existing surface. Place FHCU/SLU over primer at thickness recommended by manufacturer.
- Install tile using single or two component liquid latex Portland cement mortar or epoxy mortar. Refer to Detail 311F-2025.

#### LIMITATIONS

- Acid washing will not remove wax, sealers and oils.

#### OTHER CONSIDERATIONS

- Existing installations must be sound, well bonded and free of structural cracks. If existing installation is not structurally sound, consider use of detail 309F-2025 or the use of crack isolation membrane. See Detail 311F-2025 Detail C.
- Refer to Notes For The Professional and 301MJ-2025.
- Existing movement joints must be respected and carried through to new tile work.
- Increase in height may require adjustments to threshold or the use of a prefabricated reducer profile to meet adjacent floors.

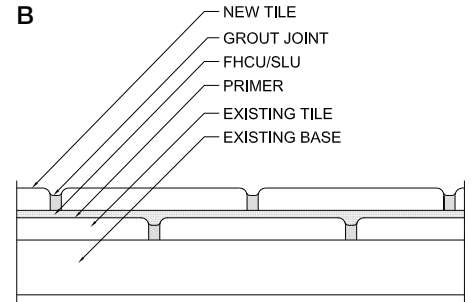

# EXTERIOR DECKS

## 325ED-2025



Please refer to page 7.

### SUITABLE SUBSTRATES

- Exterior concrete slab.
- Exterior grade plywood over wood joist at maximum of 406 mm o.c. Floor systems, including the framing system and subfloor panels, over which the tile will be installed shall be in conformance with the Canadian National Building Code 2015 and applicable local building codes taking into consideration anticipated live and dead loads.

### MATERIALS

- TILE – meeting ANSI A137.1, A137.2, A137.3, and for areas of use as recommended by the tile manufacturer
- BOND COAT – Single or two component liquid latex-Portland cement mortar (minimum acceptable standard ANSI A118.4 or ISO 13007 C2S1).
- GROUT – Latex-Portland cement (minimum acceptable standard ANSI A118.6 or ISO 13007 CG1).
- Waterproofing membrane ANSI A118.10.

### APPLICATION

#### DETAIL A

- Concrete slab must be sloped a minimum of 2% (approximately 6 mm per 300 mm). If not located over occupied space a waterproofing membrane meeting ANSI A118.10 may be substituted for roofing membrane.
- Finished tolerance of mortar bed not to exceed 6 mm in 3000 mm or 2 mm in 300 mm. Tighter tolerances are required when large format tile will be installed.
- Drainage layer mat is applied to the surface of the waterproofing layer but not bonded. Mortar bed thickness should be not less than 38 mm. Use of latex additive in mortar bed (see Tile Guide Specification Section Mixes 2.9.2.5) and bond coat is mandatory. Contact shall be evenly distributed to give full support of the tile. Use proper notched trowel to ensure adequate bond. With pressure, apply a coat of mortar by using the trowel's flat side to key the mortar into the substrate. Apply additional mortar, combing it in a single direction parallel to the tile's shortest dimension, with the trowel's notched side. Place the tiles firmly into the wet bond coat. Push the tiles back and forth in a direction perpendicular to trowel lines, to collapse the mortar ridges and to help achieve maximum coverage. Ensure proper contact between mortar, tile and substrate by periodically lifting a few tiles to check for acceptable coverage. Use sufficient bond coat to ensure minimum 95% contact with back of tile (it may be necessary to back-butter the tile in order to meet this requirement). Remove excess mortar from the joint areas so that at least 2/3 of the tile depth is available for grouting. Allow bond coat to cure. Force grout into the joints with a rubber grout float. Make sure all joints are well-compacted and free of voids and gaps. Remove excess grout from the tile surface and clean.
- Reinforcing mesh 51 mm x 51 mm x 1.6 mm installed in mortar bed over membrane.

#### DETAIL B

- Sub-floor – 16 mm exterior grade plywood meeting CSA 0121, sloped as per Detail A. Install roofing membrane and drainage layer in accordance to manufacturer's recommendations. Install mortar be in accordance to Detail A.

#### DETAIL C

- Sub-floor – 16 mm exterior grade plywood meeting CSA 0121, sloped as per Detail A. Backer unit 13 mm minimum and must be exterior rated. Backer unit bond coat and fasteners as recommended by manufacturer. Backbuttering is recommended to bond tile to achieve 95% mortar contact.
- Apply approved roofing membrane and primer as recommended by manufacturer.

#### DETAIL D

- Sub-floor – 16 mm exterior grade plywood meeting CSA 0121, sloped as per Detail A. Overlay of plywood and installation as in Detail 313F-2025 Detail A. Overlay of plywood can be substituted with cementitious backer unit (CBU) as in Detail C. Roofing membrane is a self applied modified rubberized asphalt Styrene-Butadiene-Styrene(SBS) membrane or other membrane types as recommended by manufacturer. Uncoupling system is applied directly onto roofing membrane as per manufacturer's instructions. For definition of uncoupling system see Glossary. Backbuttering is recommended to bond tile to achieve 95% mortar contact. NOTE: This system can also be used over a concrete slab instead of plywood especially for areas over living space.

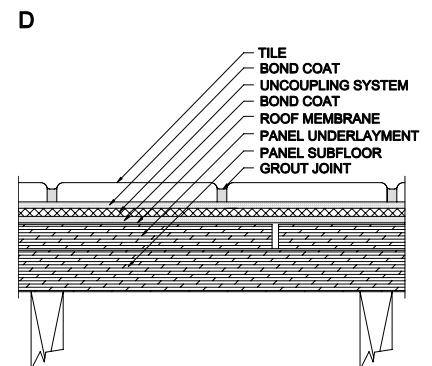
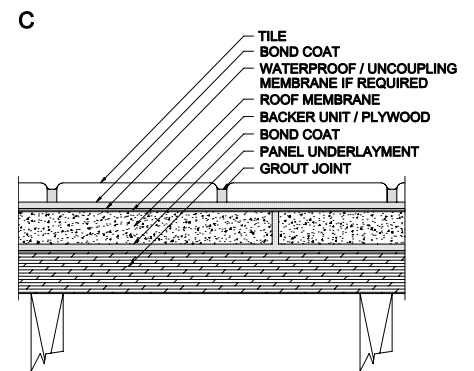
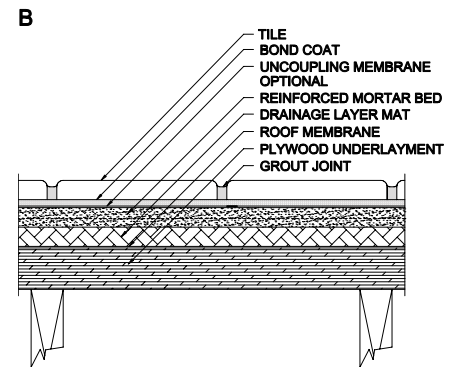
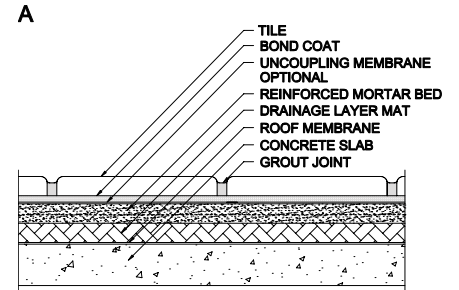

Continued

## EXTERIOR DECKS 325ED-2025

### DETAIL E

- Exterior Deck Over Occupied Space – concrete slab and finished surface to be sloped a minimum of 2% (approximately 6 mm per 300 mm). See Detail 326 DR-2025 (B).
- A waterproofing membrane meeting ANSI A118.10 may be under the tile. A roofing membrane must be installed over the structural slab.
- Drainage layer mat must be applied to the roofing membrane but not bonded. Mortar bed thickness should not be less than 38 mm.
- Heavy or extra heavy duty tile to be used.
- Finished tolerance of mortar bed not to exceed 6 mm in 3000 mm or 2 mm in 300 mm.
- Rigid insulation must be Type 4 polystyrene.

### LIMITATIONS

- DETAILS B & C – are effective methods of installation for exterior applications that can have a relatively long life span. It should however be recognized that plywood by its own nature will age and be affected by the elements. Consequently, some maintenance and/or repair may be required over time. Examine each manufacturer's system and be advised of the expected life span and guarantee so that the best system for the installation in question can be chosen. i.e. regions under extreme freeze/thaw or high rainfall conditions.
- Detail C – Verify with roofing membrane manufacturer if tile or stone can be direct bonded to membrane.

### OTHER CONSIDERATIONS

- As of 2005/2006 changes to the Canadian National Building Code require exterior decks, (regardless of over living space or not), are deemed to be roofs and require an approved roofing material Section 9.26 Roofing and Section 9.26.4.1 and 9.27.3.8.) if they are not flow-through.
- It is essential that movement joints be incorporated into the tiled surface as per Detail 301MJ-2025.
- Water must not be added to latex and Portland cement bonding material.
- Care must be taken in flashing the waterproofing against all perpendicular surfaces, 150 mm minimum.
- Finishing around the outer edges of the deck should be considered for esthetical appearance.
- For Detail A and B the thin-set method is recommended in areas subject to freeze/thaw conditions. Mortar bed may be subject to failure under these conditions.
- For Detail B, C and D a vapour retarder may be applied underneath wood sub-floor. Consultant to specify location.
- For Detail A & B a drainage modular screed system can be used to eliminate wire lath and to drain any moisture that may have penetrated the screed. See 314F Detail G page 69
- Refer to Notes For The Professional and 301MJ-2025.
- Drains should be designed to permit drainage of water at the tile surface and the surface of the waterproofing membrane. For drainage see Detail 326DR-2025. Latex-Portland cement mortars may require 14 – 60 days cure before exposure to water. Verify with the manufacturer the correct cure time required. Alternatively, to reduce the curing time required, a rapid set mortar may be more suitable.
- Waterproofing membrane if required must be specified. (ANSI A118.10) Follow manufacturers' recommendations.
- Uncoupling Membrane – follow manufacturer's recommendations for appropriate mortars: membrane must achieve 0.3 N/mm<sup>2</sup> (50 PSI or greater) shear bond strength after 7 days per the test method in ANSI A118.12 section 5.1.3.
- Bond Coat to Uncoupling membrane- Dry-set mortar (minimum acceptable standard ANSI A118.1 or ISO C1, Latex Portland cement mortar (minimal acceptable standard ANSI A118.4 or ISO 13007 C2S1) or Improved Modified Dry-set cement mortar (minimal acceptable standard ANSI A118.15 or ISO 13007 C2 F and/or T, and/or S1, modified epoxy emulsion mortars or 100% solids epoxy mortars (minimum acceptable standard ANSI A118.3 or ISO 13007 RG).

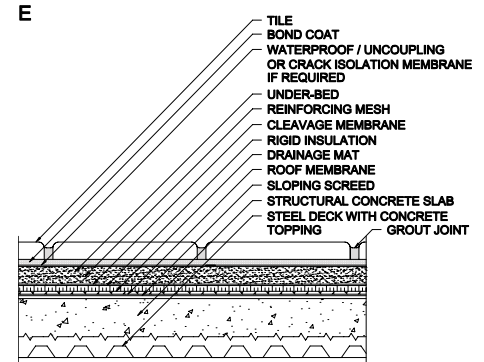

# DRAINAGE SYSTEMS INTERIOR/EXTERIOR

## 326DR-2025

### SUITABLE SUBSTRATES

- Concrete or masonry
- Exterior grade plywood
- Shower pan or waterproofing membrane over structural base
- Exterior deck over steel pan or suspended slab
- Wall constructed in accordance with Details 302W-2025, 303W-2025, 304W-2025, 305W-2025 A or B, 307W-2025, 308W-2025.

### MATERIALS

- TILE – meeting ANSI A137.1, A137.2, A137.3, and for areas of use as recommended by the tile manufacturer
- Waterproofing membrane ANSI A118.10.
- MORTAR BED minimum 20 mm to 51 mm sloped to drain. See Tile Guide Specification Section mixes 2.9.2.3 and 2.9.2.5.
- BACKING – Minimum 13 mm, Gypsum Board (ASTM C36), Cementitious Backer Unit (CBU) (ANSI A118.9), Coated Glass Mat Backer Board (ASTM C1178) or nominal 11 mm Fibre Cement Backer Board (ASTM C1288).
- BOND COAT – Dry set mortar or latex Portland cement mortar over mortar bed cured minimum of 24 hours.
- GROUT – Portland cement or Latex Portland cement
- TAPE – 51 mm wide fibre mesh tape
- Drain – With integrated bonding flange complying with CSA B-79(R2005) or double weep drain complying with equivalent CSA standard.

### APPLICATION

- Slope mortar bed a minimum of 2% (approximately 6 mm per 300 mm). Mortar bed thickness should not be less than 20 mm in thickness. Waterproofing membrane must turn up wall at least 150 mm for exterior applications and up the wall to shower head level for interior applications. Waterproofing membrane must completely cover integrated bonding flange. Drain grate to be set flush with the surface of the tile. Use sufficient bond coat to ensure minimum 95% contact. Contact shall be evenly distributed to give full support of the tile.

### LIMITATIONS

- Requires integrated bonding flange for bonded waterproofing membranes
- Interior applications waterproofing membrane must be used to the anticipated level of moisture exposure.
- Detail 304W-2025 and 305W-2025 (B) are not for exterior use.
- Detail 304W-2025 must have waterproofing membrane installed on surface (ANSI A118.10).
- For high use showers and wet areas (hotels, gang showers, sports facilities etc.) a waterproofing membrane to be used.
- All openings and cuts must be treated to ensure waterproofing integrity.
- For Detail B a drainage layer may be incorporated over the waterproofing membrane as recommended by manufacturer.
- Tile should be moisture resistant.
- Refer to Notes For The Professional and 301MJ-2025.

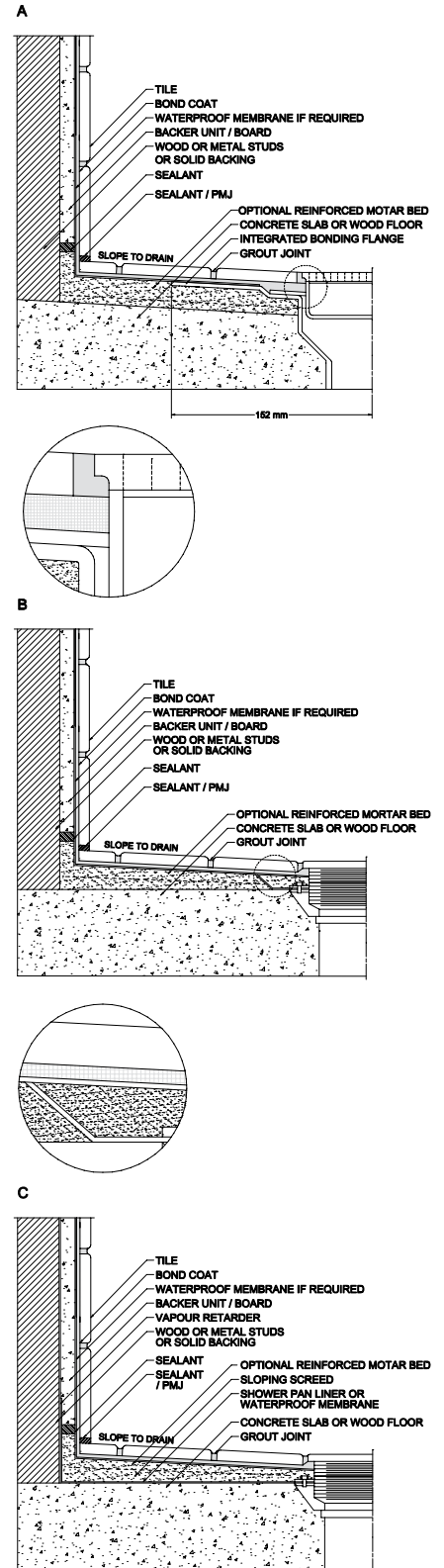

# LARGE FORMAT (FUSED) GLASS TILE ON INTERIOR FLOORS

## 327GTF-2025



Please refer to page 7.

### SUITABLE SUBSTRATES

- For use on stable substrates such as cured concrete, double layer of plywood, 12.5 mm CBU suitably installed on plywood subfloor, mortar bed suitably installed on plywood subfloor or other rigid subfloor systems.
- Dry interiors only, unless provided with a suitable waterproofed structure and sloped to drain.
- Provide a suitable rigid subfloor that is designed to support the maximum loading anticipated for the area to be tiled. Floor systems, including the framing system and subfloor panels, over which the tile will be installed shall be in conformance with the Canadian National Building Code 2015 and applicable local building codes taking into consideration anticipated live and dead loads.

### MATERIALS

- TILE\* – meeting A137.2, A137.3, and for areas of use as recommended by the tile manufacturer
- CRACK ISOLATION MEMBRANE – ANSI A118.12 (follow membrane manufacturer's instructions for use on vertical surfaces).
- UNCOUPLING MEMBRANE – following manufacturer's recommendations.
- BOND COAT -- White, rapid curing, cement mortar (minimum acceptable standard ANSI A118.15 or ISO 13007 C2S1).
- GROUT – Polymer modified tile grout per manufacturer's recommendation.

### APPLICATION

- Apply crack isolation membrane (ANSI A108.17) or uncoupling membrane following manufacturer's recommendations to provide complete coverage of the substrate in the area on which the large format glass tile is to be installed. Since many large format glass tiles are somewhat translucent it is very important that complete coverage be achieved by back buttering each piece of tile with white thin-set mortar immediately prior to setting the tile to ensure that no voids or bubbles are visible against the back of the glass tile. Install tile in accordance with ANSI A 108.5 – use the minimum thickness of thin-set mortar that is recommended by the thin-set manufacturer – the maximum mortar thickness between the tile and C.I.M. is to be no greater than 3 mm after the tile has been beaten into place. An adequate thickness of thin-set mortar can generally be applied with a 5 mm V-notched trowel.

### LIMITATIONS

- This method is suitable only for large format glass floor tiles which are manufactured by fully fusing the colors / glazes / finishes with the glass body at temperatures above 550°C.
- Cutting of glass tile - any cuts, other than those that are hidden in inside corners, should be performed using a diamond blade designed for cutting glass on a wet saw – glass tile should be cut with the rotation of the saw blade into the glazed (back) side of the tile – on most saws this is face down.
- Do not use epoxy bond coat or grout unless recommended by manufacturer.

### OTHER CONSIDERATIONS

- Movement Joint (architect must specify type of joint and show location and details on drawings).
- Movement joints - mandatory according to Detail 301MJ-2025.
- There is a new standard for glass tile called ANSI A137.2 which should be consulted for types, size and performance which includes large format glass tile.
- Use of a Lippage Control device may be required.

\* Notes on Large format tiles, Guaged Porcelain and Porcelain Panels/Slabs can be found on pages 12 -13.

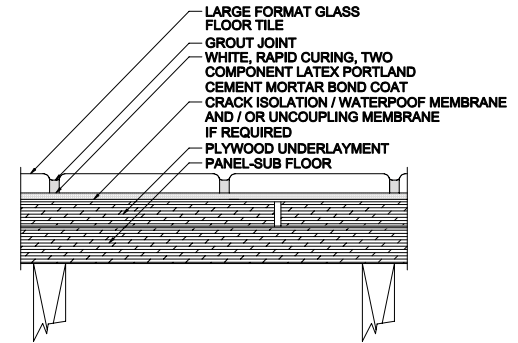
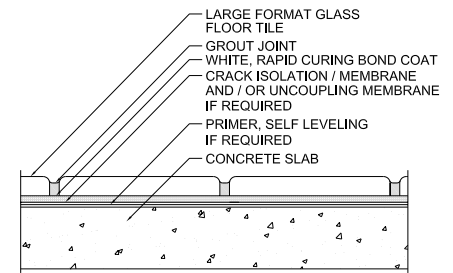

# LARGE FORMAT (FUSED) GLASS TILE ON INTERIOR WALLS

## 328GTW-2025



Please refer to page 7.

### SUITABLE SUBSTRATES

- For installation on the following stable substrates: Gypsum Board, CBU, Fiber Cement Underlayment, Coated Glass Mat Water Resistant Gypsum Boards or Cured Mortar Bed.
- Gypsum Board for dry interiors only.
- Over dry, well-braced wood studs or furring.
- Over well-braced metal studs.

### MATERIALS

- Gypsum board – ASTM C36 or C630.
- CBU – ANSI A118.9, installed in accordance with ANSI A108.9.
- Fibre Cement Underlayment – ASTM C1288.
- Cured mortar bed, lath and membrane – ANSI A108.1B.
- Crack Isolation Membrane – ANSI A118.12 (follow membrane manufacturer's instructions for use on vertical surfaces).
- Waterproofing Membrane – ANSI A118.10. Follow manufacturer's recommendations.
- Vapor/moisture barrier membrane (when required) to be 15 lb. roofing felt or minimum 4-mil polyethylene film.
- TILE\* – meeting A137.2, A137.3, and for areas of use as recommended by the tile manufacturer
- BOND COAT – White, rapid curing, two component latex-Portland cement mortar (minimum acceptable standard ANSI A118.4 or ISO 13007 C2S1).
- GROUT – Polymer modified tile grout per manufacturer's recommendation.

### APPLICATION

- Crack Isolation Membrane – ANSI A108.17 or follow the CIM manufacturer's recommendations – to provide complete coverage of the substrate in the area on which the large format glass tile is to be installed.
- Waterproofing membrane – ANSI A108.3 or follow the CIM manufacturer's recommendations.
- Since many large format glass tiles are somewhat translucent it is very important that complete coverage be achieved by back buttering each piece of tile with white thin-set mortar immediately prior to setting the tile to ensure that no voids or bubbles are visible against the back of the glass tile.
- Install tile in accordance with ANSI A108.5 – use the minimum thickness of thin-set mortar that is recommended by the thin-set manufacturer – the maximum mortar thickness between the tile and C.I.M. is to be no greater than 3 mm after the tile has been beaten into place. An adequate thickness of thin-set mortar can generally be applied with a 5 mm V-notched trowel.
- Cutting of glass tile for any cuts other than those that are hidden in inside corners should be performed using a diamond blade designed for cutting glass on a wet saw – glass tile should be cut with the rotation of the saw blade into the glazed (back) side of the tile – on most saws this is face down.

### LIMITATIONS

- This method is suitable only for large format glass tiles which are manufactured by fully fusing the colors/glazes/finishes with the glass body at temperatures above 550°C.
- Do not use regular gypsum board in wet areas such as tub & shower enclosures.
- Do not use in areas where gypsum board is exposed to temperatures above 52°C.

### OTHER CONSIDERATIONS

- Maximum stud spacing – 406 mm o.c.
- Minimum recommended metal stud depth 92 mm.
- Metal studs – 20 gauge or heavier.
- Movement Joint (architect must specify type of joint and show location and details on drawings).
- Movement joints – mandatory, according to Detail 301MJ-2025.
- Large Format Glass Tile with a facial surface area > 57.76 cm<sup>2</sup> and a surface area not greater than or equal to 3721 cm<sup>2</sup> (not greater than or equal to 930 cm<sup>2</sup> for cast glass) and such that the longest side is not greater than 4.25 times the shortest side.
- Use of a Lippage Control device may be required.

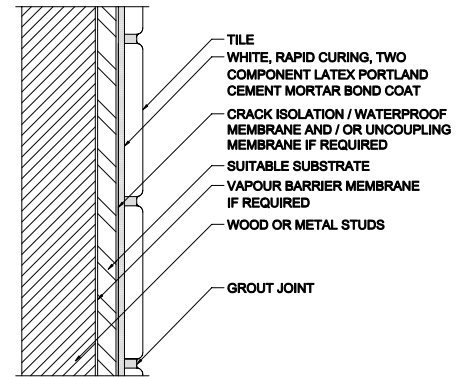

# LARGE FORMAT TILE ON INTERIOR FLOORS

## 329 LFT -2025

### SUITABLE SUBSTRATES

- For use on stable substrates such as cured concrete, double layer of plywood, 12.5 mm CBU suitably installed on plywood subfloor, mortar bed suitably installed on plywood subfloor or other rigid subfloor systems (Drawings refer to 311F-A, 313F-A,B,D).
- Dry interiors only, unless provided with a suitable waterproofed structure and sloped to drain.
- Provide a suitable rigid subfloor that is designed to support the maximum loading anticipated for the area to be tiled. Floor systems, including the framing system and subfloor panels, over which the tile will be installed shall be in conformance with the Canadian National Building Code 2015 and applicable local building codes taking into consideration anticipated live and dead loads.

### MATERIALS

- TILE\* – meeting A137.2, A137.3, and for areas of use as recommended by the tile manufacturer
- SELF-LEVELLING UNDERLAYMENT – Cement-based, quick-setting, self-levelling, self-drying underlayment for engineer-approved floors, very fluid once mixed, installation from featheredge 6 mm to at least 138 mm in a single application.
- CRACK ISOLATION MEMBRANE – ANSI A118.12 (follow membrane manufacturer's instructions for use on vertical surfaces).
- UNCOUPLING MEMBRANE – Follow manufacturer's recommendations.
- BOND COAT – Full coverage Large and Heavy Tile mortars, latex-Portland cement mortar (minimum acceptable standard ANSI A118.4 or ISO 13007 C2S1), modified epoxy emulsion mortars or 100% solids epoxy mortar (minimum acceptable standard ANSI A118.3 or ISO 13007 R1).
- GROUT – Polymer-modified sanded tile grout (minimum acceptable standard ANSI A118.7 or ISO 13007 CG2).

### APPLICATION

- Measure deflections on the floor using a 10ft straight-edge prior to commencing any installation.
- Apply crack isolation membrane (ANSI A108.17) or uncoupling membrane following manufacturer's recommendations to provide complete coverage of the substrate in the area on which the large format tile is to be installed. Use recommended notch trowel for setting larger format tiles. Apply mortar into substrate with flat side of trowel. This ensures complete contact to the pores of the substrate. It is very important that complete coverage be achieved by back buttering each piece of tile with thin-set mortar immediately prior to setting the tile to ensure that no voids are present against the back of the tile.
- Follow ANSI A108.19 for important information pertaining to the installation of gauged porcelain tiles and gauged porcelain tile panels/slabs (note that this installation standard is restricted for indoor installation, a standard for an outdoor installation is under development).
- Use proper notched trowel to ensure adequate bond. With pressure, apply a coat of mortar by using the trowel's flat side to key the mortar into the substrate. Apply additional mortar, combing it in a single direction parallel to the tile's shortest dimension, with the trowel's notched side. Place the tiles firmly into the wet bond coat. Push the tiles back and forth in a direction perpendicular to trowel lines, to collapse the mortar ridges and to help achieve maximum coverage. Ensure proper contact between mortar, tile and substrate by periodically lifting a few tiles to check for acceptable coverage. Use sufficient bond coat to ensure minimum 95% contact with back of tile (it may be necessary to back-butter the tile in order to meet this requirement). Special attention should be paid to ensure complete coverage of the bond coat to the edges of the tiles. It is particularly important to have enough staff to apply the tie coat so that tiles are installed while the product is still wet and sticky. Remove excess mortar from the joint areas so that at least 2/3 of the tile depth is available for grouting. Allow bond coat to cure. Force grout into the joints with a rubber grout

### LIMITATIONS

- Manufacturer's recommendations must be followed.
- Surface variation should not exceed 3 mm in 3000 mm and 1.5 mm in 600 mm.
- Provide positive drainage below interior slabs; use latex-Portland cement mortars on exterior slabs. Use of epoxy mortars and grouts is recommended for interior surfaces only or where improved chemical resistance is required.
- Use method 309F-2019-2021 or crack isolation/uncoupling membrane if recommended by the manufacturer for precast floor systems, post tensioned concrete floor systems and other floors subject to movement or deflection.

### OTHER CONSIDERATIONS

- For exterior installations, use a suitable latex-Portland cement mortar or manufacturer's recommendations. Backbuttering of the tile is required to achieve 95% contact.
- Tile used in exterior applications must be frost resistant.
- Refer to Notes For The Professional and 301MJ-2025.
- Waterproofing membrane if required must be specified. (ANSI A118.10) Follow manufacturer's recommendations
- For exterior use concrete slab must be sloped to provide positive surface drainage and adequate drainage below slab must be provided.
- Movement Joint (architect must specify type of joint and show location and details on drawings)
- There is a new standard for gauged porcelain tiles and gauged porcelain tile panels/slabs as per ANSI A137.3 which should be consulted for types, size and performance.
- Use of a Lippage Control device may be required.

\* Notes on Large format tiles, Gauged Porcelain and Porcelain Panels/Slabs can be found on pages 12 -13.

# LARGE FORMAT TILE ON INTERIOR WALLS

## 330LFTW -2025

### SUITABLE SUBSTRATES

- For installation on the following stable substrates: Gypsum Board, CBU, Fiber Cement Underlayment, Coated Glass Mat Water Resistant Gypsum Boards or Cured Mortar Bed.
- Gypsum Board for dry interiors only.
- Over dry, well-braced wood studs or furring.
- Over well-braced metal studs (For drawings refer to 304W,305W-A,B,307W) NOTE: The maximum loading recommended for Gypsum Board is 5lbs/ sf including setting and grouting materials.

### MATERIALS

- TILE\* – meeting A137.2, A137.3, and for areas of use as recommended by the tile manufacturer
- Gypsum Board – ASTM C36 or C630.
- CBU – ANSI A118.9, installed in accordance with ANSI A108.9.
- Fibre Cement Underlayment – ASTM C1288.
- Cured mortar bed, lath and membrane – ANSI A108.1B.
- Crack Isolation Membrane – ANSI A118.12 (follow manufacturer's instructions for use on vertical surfaces).
- Waterproofing membrane – ANSI A118.10. Follow manufacturer's recommendations.
- Vapor/moisture barrier membrane (when required) to be 15 lb. roofing felt or minimum 4-mil polyethylene film.
- LEVELLING COMPOUND – Cementitious patching compound as per manufacturer's recommendations.
- BOND COAT – Latex-Portland cement mortar (minimum acceptable standard ANSI A118.4 or ISO 13007 C2S1), modified epoxy emulsion mortars or 100% solids epoxy mortar (minimum acceptable standard ANSI A118.3 or ISO 13007 R1).
- GROUT – Polymer-modified sanded tile grout (minimum acceptable standard ANSI A118.7 or ISO 13007 CG2).

### APPLICATION

- Measure deflections on the floor or wall using a 3 m straight-edge prior to commencing any installation.
- Crack Isolation Membrane – ANSI A108.17 or follow the CIM manufacturer's recommendations – to provide complete coverage of the substrate in the area on which the large format tile is to be installed.
- Waterproofing membrane – ANSI A108.3 or follow the CIM manufacturer's recommendations. Use recommended notch trowel for setting larger format tiles. Apply mortar into substrate with flat side of trowel. This ensures complete contact to the pores of the substrate. It is very important that complete coverage be achieved by back buttering each piece of tile with thin-set mortar immediately prior to setting the tile to ensure that no voids are present against the back of the tile.
- Follow ANSI 108.19 for important information pertaining to the installation of gauged porcelain tiles and gauged porcelain tile panels/slabs (note that this installation standard is restricted for indoor installation, a standard for an outdoor installation is underdevelopment).
- Use proper notched trowel to ensure adequate bond. With pressure, apply a coat of mortar by using the trowel's flat side to key the mortar into the substrate. Apply additional mortar, combing it in a single direction parallel to the tile's shortest dimension, with the trowel's notched side. Place the tiles firmly into the wet bond coat. Push the tiles back and forth in a direction perpendicular to trowel lines, to collapse the mortar ridges and to help achieve maximum coverage. Ensure proper contact between mortar, tile and substrate by periodically lifting a few tiles to check for acceptable coverage. Use sufficient bond coat to ensure minimum 95% contact with back of tile (it may be necessary to back-butter the tile in order to meet this requirement). Special attention should be paid to ensure complete coverage of the bond coat to the edges of the tiles. Remove excess mortar from the joint areas so that at least 2/3 of the tile depth is available for grouting. Allow bondcoat to cure. Force grout into the joints with a rubber grout float. Make sure all joints are well-compacted and free of voids and gaps. Remove excess grout from the tile surface and clean.

### LIMITATIONS

- Do not use regular gypsum board in wet areas such as tub & shower enclosures.
- Do not use in areas where gypsum board is exposed to temperatures above 52°C.
- Maximum variation of slab should not exceed 6 mm in 3000 mm or 2 mm in 300 mm.
- Surface variation should not exceed 3 mm in 3000 mm and 1.5 mm in 600 mm.

### OTHER CONSIDERATIONS

- Maximum stud spacing – 406 mm o.c.
- Minimum recommended metal stud depth 92 mm.
- Metal studs – 20 gauge or heavier.
- Movement Joint (architect must specify type of joint and show location and details on drawings).
- Movement joints – mandatory, according to Detail 301MJ-2025.
- For exterior installations, use a suitable latex-Portland cement mortar. Backbuttering of the tile is required to achieve 95%contact.
- Tile used in exterior applications must be frost resistant.
- Refer to Notes For The Professional and 301MJ-2025.
- Waterproofing membrane if required must be specified. (ANSI A118.10) Follow manufacturer's recommendations.
- There is a new standard for gauged porcelain tiles and gauged porcelain tile panels/slabs as per ANSI A137.3 which should be consulted for types, size and performance.
- Use of a Lippage Control device may be required.

\* Notes on Large format tiles, Gauged Porcelain and Porcelain Panels/Slabs can be found on pages 12 -13.

# SOUND CONTROL SYSTEMS ON INTERIOR FLOORS

## 331F-SC-2025

### DETAIL A – THIN SYSTEM OVER PLYWOOD

#### SUITABLE SUBSTRATES

- Provide a suitable rigid subfloor that is designed to support the maximum loading anticipated for the area to be tiled. Floor systems, including the framing system and subfloor panels, over which the tile will be installed shall be in conformance with the Canadian National Building Code 2015 and applicable local building codes taking into consideration anticipated live and dead loads.

#### MATERIALS

- SOUND REDUCTION MEMBRANE – meets ANSI A118.13 standard for Bonded Sound Reduction Membranes for Thin-set Ceramic Tile and Dimension Stone Installation. This standard applies to trowel applied, liquid and flexible sheet membranes.
- BOND COAT – Latex-Portland cement mortar (minimum acceptable standard ANSI A 118.4 or ISO 13007 C2), modified epoxy emulsion mortars or 100% solids epoxy mortar (minimum acceptable standard ANSI A118.3 or ISO 13007 R1).
- GROUT – Portland cement, latex-Portland cement (minimum acceptable standard ANSI A118.6 or ISO 13007 CG1) or epoxy (minimum acceptable standard ANSI A118.3 or ISO 13007 RG).
- GYPSUM BOARD – ASTM C36 Type X 15 mm-thick.
- RESILIENT CHANNELS – 1 or 2 legged.
- SOUND ABSORBENT BATT – Fibreglass batt, natural cotton fibre or other.
- ACCOUSTICAL SEALANT – ASTM C919.

#### APPLICATION

- Apply sound reduction membrane following manufacturer's recommendations to provide complete coverage of the substrate in the area on which the tile is to be installed.
- All perimeters must be recessed away from the walls and acoustic sealant or prefabricated movement joints must be applied. Use proper notched trowel to ensure adequate bond. With pressure, apply a coat of mortar by using the trowel's flat side to key the mortar into the substrate. Apply additional mortar, combing it in a single direction parallel to the tile's shortest dimension, with the trowel's notched side. Place the tiles firmly into the wet bond coat. Push the tiles back and forth in a direction perpendicular to trowel lines, to collapse the mortar ridges and to help achieve maximum coverage. Ensure proper contact between mortar, tile and substrate by periodically lifting a few tiles to check for acceptable coverage. Use sufficient bond coat to ensure minimum 80% contact to the back of the tile with back of tile. For tile with any edge longer than 380 mm use sufficient bond coat to ensure minimum 95% contact, with the corners and edges fully supported. Remove excess mortar from the joint areas so that at least 2/3 of the tile depth is available for grouting. Allow bond coat to cure. Force grout into the joints with a rubber grout float. Make sure all joints are well-compacted and free of voids and gaps. Remove excess grout from the tile surface and clean.

#### LIMITATIONS

- Some systems may require epoxy grout and/or epoxy bond-coat.
- Some products/systems cannot be used in commercial applications where heavy loads and carts will be used. A "Light Commercial" to "Heavy Commercial" rating utilizing ASTM C627 should be required.

#### OTHER CONSIDERATIONS

- Sound reduction membranes are intended to minimize the transfer of sound from one room to the room below, it is however only part of the overall system. Substrates, flooring material, dropped ceiling assemblies, perimeter joints, etc., will all affect the overall values.
- Movement Joint (architect must specify type of joint and show location and details on drawings).
- Movement joints - mandatory according to Detail 301MJ-2025.
- All systems must meet or exceed a "Residential Rating" with ASTM C627.
- Some systems require 2 layers of 15 mm type X Gypsum Ceiling.
- Refer to notes on "Sound Control Underlayment".
- Ratings may vary from 46 IIC to approximately 54 IIC using ASTM E492 depending on product and other components in the system.
- This floor assembly has little or no effect on STC rating, normally this floor assembly will have an STC of 50 or more, when the appropriate sound rated wall detail is used.

Continued

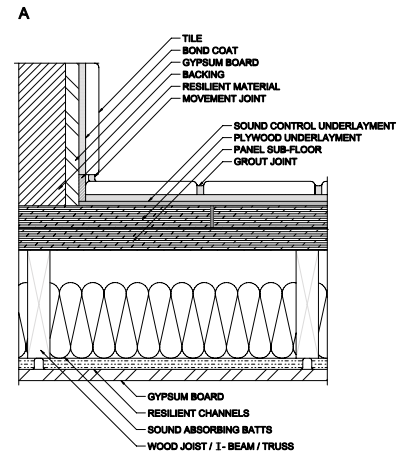

# SOUND CONTROL SYSTEMS ON INTERIOR FLOORS

## 331F-SC-2025

### DETAIL B – THICK SYSTEM OVER PLYWOOD

#### SUITABLE SUBSTRATES

- Provide a suitable rigid subfloor that is designed to support the maximum loading anticipated for the area to be tiled. Floor systems, including the framing system and subfloor panels, over which the tile will be installed shall be in conformance with the Canadian National Building Code 2015 and applicable local building codes taking into consideration anticipated live and dead loads.

#### MATERIALS

- SOUND REDUCTION MEMBRANE – as per manufacturer's recommendations. A wide range of resilient material can be used including crumbled rubber, cork, foam and other resilient materials.
- BOND COAT – Dry-set mortar (minimum acceptable standard ANSI A118.1 or ISO 13007 C1), latex-Portland cement mortar (minimum acceptable standard ANSI A118.4 or ISC 13007 C2), modified epoxy emulsion mortars or 100% solids epoxy mortar (minimum acceptable standard ANSI A118.3 or ISO 13007 R1).
- GROUT – Portland cement, latex-Portland cement (minimum acceptable standard ANSI A118.6 or ISC 13007 CG1) or epoxy (minimum acceptable standard ANSI A118.3 or ISO 13007 RG), or RTU grout.
- GYPSUM BOARD – ASTM C36 Type X 15 mm-thick
- RESILIENT CHANNELS – 1 or 2 legged
- SOUND ABSORBENT BATT – fibreglass batt, natural cotton fibre or other
- ACCOUSTICAL SEALANT – ASTM C919

#### APPLICATION

- Apply sound reduction membrane following manufacturer's recommendations to provide complete coverage of the substrate
- Apply mortar bed (see Tile Guide Specification Section Mixes 2.9.2.5) to required thickness over fresh slurry bond coat (see Tile Guide Specification Section Mixes 2.9.2.2). Finished tolerance of mortar bed not to exceed 6 mm in 3000 mm or 2 mm in 300 mm.
- Use proper notched trowel to ensure adequate bond. With pressure, apply a coat of mortar by using the trowel's flat side to key the mortar into the substrate. Apply additional mortar, combing it in a single direction parallel to the tile's shortest dimension, with the trowel's notched side. Place the tiles firmly into the wet bond coat. Push the tiles back and forth in a direction perpendicular to trowel lines, to collapse the mortar ridges and to help achieve maximum coverage. Ensure proper contact between mortar, tile and substrate by periodically lifting a few tiles to check for acceptable coverage. Use sufficient bond coat to ensure minimum 80% contact to the back of the tile with back of tile. Remove excess mortar from the joint areas so that at least 2/3 of the tile depth is available for grouting. Allow bond coat to cure. Force grout into the joints with a rubber grout float. Make sure all joints are well-compacted and free of voids and gaps. Remove excess grout from the tile surface and clean. All perimeters must be recessed away from the walls and acoustic sealant or prefabricated movement joints must be applied.

#### LIMITATIONS

- Some products/systems cannot be used in commercial applications where heavy loads and carts will be used. A "Light Commercial" to "Heavy Commercial" rating utilizing ASTM C-627 should be required.
- This assembly will normally raise the floor from anywhere from 30 mm to 62.5 mm in height. Height restrictions should be evaluated. Use proper notched trowel to ensure adequate bond. With pressure, apply a coat of mortar by using the trowel's flat side to key the mortar into the substrate. Apply additional mortar, combing it in a single direction parallel to the tile's shortest dimension, with the trowel's notched side. Place the tiles firmly into the wet bond coat. Push the tiles back and forth in a direction perpendicular to trowel lines, to collapse the mortar ridges and to help achieve maximum coverage. Ensure proper contact between mortar, tile and substrate by periodically lifting a few tiles to check for acceptable coverage. Use sufficient bond coat to ensure minimum 80% contact to the back of the tile with back of tile. For tile with any edge longer than 380 mm use sufficient bond coat to ensure minimum 95% contact, with the corners and edges fully supported. Remove excess mortar from the joint areas so that at least 2/3 of the tile depth is available for grouting. Allow bond coat to cure. Force grout into the joints with a rubber grout float. Make sure all joints are well-compacted and free of voids and gaps. Remove excess grout from the tile surface and clean.

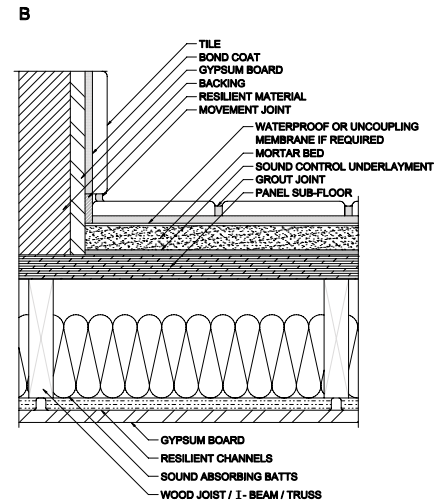

#### OTHER CONSIDERATIONS

- Sound reduction membranes are intended to minimize the transfer of sound from one room to the room below, it is however only part of the overall system. Substrates, flooring material, dropped ceiling assemblies, perimeter joints, etc., will all affect the overall values.
- Movement Joint (architect must specify type of joint and show location and details on drawings).
- Movement joints - mandatory according to Detail 301MJ-2019-2021.
- All systems must meet or exceed a "Residential Rating" with ASTM C627.
- Some systems require 2 layers of 15 mm type X Gypsum Ceiling.
- Refer to notes on "Sound Control Underlayment".
- Ratings may vary from 48 IIC to approximately 58 IIC using ASTM E492 depending on product and other components in the system. This floor assembly has little or no effect on STC rating, normally this floor assembly will have an STC of 50 or more, when the appropriate sound rated wall detail is used.
- Detail 314F-C2 Modular Screed System Over Plywood can be used as alternative to a monolithic mortar bed.

Continued

# ★ SOUND CONTROL SYSTEMS ON INTERIOR FLOORS

## 331F-SC-2025

### DETAIL B2 – FLOWABLE HYDRAULIC CEMENT / SELF-LEVELING UNDERLAYMENT OVER PLYWOOD

#### SUITABLE SUBSTRATES

- Provide a suitable rigid subfloor that is designed to support the maximum loading anticipated for the area to be tiled. Floor systems, including the framing system and subfloor panels, over which the tile will be installed shall be in conformance with the Canadian National Building Code 2015 and applicable local building codes taking into consideration anticipated live and dead loads.

#### MATERIALS

- PRIMER – per manufacturer's recommendations
- LATH - Galvanized wire lath not less than 1.4 kg/m<sup>2</sup> meeting ASTM C847 or equivalent plastic lath meeting ASTM C1764.
- FHCU /SLU – Meeting ANSI A118.16
- BONDED SOUND REDUCTION MEMBRANE – as per manufacturer's recommendations. A wide range of resilient material can be used including crumbled rubber, cork, foam and other resilient materials.
- BOND COAT – Dry-set mortar (minimum acceptable standard ANSI A118.1 or ISO 13007 C1), latex-Portland cement mortar (minimum acceptable standard ANSI A118.4 or ISC 13007 C2), modified epoxy emulsion mortars or 100% solids epoxy mortar (minimum acceptable standard ANSI A118.3 or ISO 13007 R1).
- GROUT – Portland cement, latex-Portland cement (minimum acceptable standard ANSI A118.6 or ISC 13007 CG1) or epoxy (minimum acceptable standard ANSI A118.3 or ISO 13007 RG ), or RTU grout.
- GYPSUM BOARD – ASTM C36 Type X 15 mm-thick
- RESILIENT CHANNELS – 1 or 2 legged
- SOUND ABSORBENT BATT – fibreglass batt, natural cotton fibre or other
- ACCOUSTICAL SEALANT – ASTM C919

#### APPLICATION

- Apply primer, then attach lath to plywood. (Some underlayment formulations, including fiber-reinforced formulations, do not require lath)
- Place FHCU/SLU at thickness recommended by manufacturer, typically up to 38mm per lift and at least 13mm over lath and plywood. Finished tolerance of FHCU/SLU not to exceed 6 mm in 3000 mm or 2 mm in 300 mm.
- Apply bonded sound reduction membrane following manufacturer's recommendations to provide complete coverage of the substrate
- Use proper notched trowel for bond coat to ensure adequate bond. With pressure, apply a coat of mortar by using the trowel's flat side to key the mortar into the substrate. Apply additional mortar, combing it in a single direction parallel to the tile's shortest dimension, with the trowel's notched side. Place the tiles firmly into the wet bond coat. Push the tiles back and forth in a direction perpendicular to trowel lines, to collapse the mortar ridges and to help achieve maximum coverage. Ensure proper contact between mortar, tile and substrate by periodically lifting a few tiles to check for acceptable coverage. Use sufficient bond coat to ensure minimum 80% contact to the back of the tile with back of tile. Remove excess mortar from the joint areas so that at least 2/3 of the tile depth is available for grouting. Allow bond coat to cure. Force grout into the joints with a rubber grout float. Make sure all joints are well-compacted and free of voids and gaps. Remove excess grout from the tile surface and clean. All perimeters must be recessed away from the walls and acoustic sealant or prefabricated movement joints must be applied.

#### LIMITATIONS

- Some products/systems cannot be used in commercial applications where heavy loads and carts will be used. A "Light Commercial" to "Heavy Commercial" rating utilizing ASTM C-627 should be required.
- This assembly will normally raise the floor from anywhere from 24 mm to 62.5 mm in height. Height restrictions should be evaluated. Use proper notched trowel to ensure adequate bond. With pressure, apply a coat of mortar by using the trowel's flat side to key the mortar into the substrate. Apply additional mortar, combing it in a single direction parallel to the tile's shortest dimension, with the trowel's notched side. Place the tiles firmly into the wet bond coat. Push the tiles back and forth in a direction perpendicular to trowel lines, to collapse the mortar ridges and to help achieve maximum coverage. Ensure proper contact between mortar, tile and substrate by periodically lifting a few tiles to check for acceptable coverage. Use sufficient bond coat to ensure minimum 80% contact to the back of the tile with back of tile. For tile with any edge longer than 380 mm use sufficient bond coat to ensure minimum 95% contact, with the corners and edges fully supported. Remove excess mortar from the joint areas so that at least 2/3 of the tile depth is available for grouting. Allow bond coat to cure. Force grout into the joints with a rubber grout float. Make sure all joints are well-compacted and free of voids and gaps. Remove excess grout from the tile surface and clean.

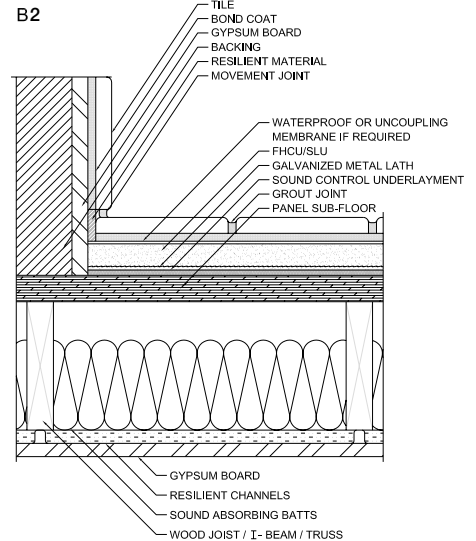

# SOUND CONTROL SYSTEMS ON INTERIOR FLOORS

## 331F-SC-2025

### DETAIL C – THIN SYSTEM ON CONCRETE WITH DROPPED CEILING

#### MATERIALS

- SOUND REDUCTION MEMBRANE – meets ANSI A118.13 standard for Bonded Sound Reduction Membranes for Thin-set Ceramic Tile and Dimension Stone Installation. This standard applies to trowel applied, liquid and flexible sheet membranes.
- BOND COAT – Dry-set mortar (minimum acceptable standard ANSI A118.1 or ISO 13007 C1), latex-Portland cement mortar (minimum acceptable standard ANSI A118.4 or ISO 13007 C2), modified epoxy emulsion mortars or 100% solids epoxy mortar (minimum acceptable standard ANSI A118.3 or ISO 13007 R1).
- GROUT – Portland cement, latex-Portland cement (minimum acceptable standard ANSI A118.6 or ISO 13007 CG1) or epoxy (minimum acceptable standard ANSI A118.3 or ISO 13007 RG), or RTU grout.
- GYPSUM BOARD – ASTM C36 Type X 15 mm-thick.
- RESILIENT CHANNELS – 1 or 2 legged.
- SOUND ABSORBANT BATT – Fibreglass batt, natural cotton fibre or other.
- ACCOUSTICAL SEALANT – ASTM C919.

#### APPLICATION

- Apply sound reduction membrane following manufacturer's recommendations to provide complete coverage of the substrate in the area on which the tile is to be installed.
- All perimeters must be recessed away from the walls and acoustic sealant or prefabricated movement joints must be applied. Use proper notched trowel to ensure adequate bond. With pressure, apply a coat of mortar by using the trowel's flat side to key the mortar into the substrate. Apply additional mortar, combing it in a single direction parallel to the tile's shortest dimension, with the trowel's notched side. Place the tiles firmly into the wet bond coat. Push the tiles back and forth in a direction perpendicular to trowel lines, to collapse the mortar ridges and to help achieve maximum coverage. Ensure proper contact between mortar, tile and substrate by periodically lifting a few tiles to check for acceptable coverage. Use sufficient bond coat to ensure minimum 80% contact to the back of the tile with back of tile. For tile with any edge longer than 380 mm use sufficient bond coat to ensure minimum 95% contact, with the corners and edges fully supported. Remove excess mortar from the joint areas so that at least 2/3 of the tile depth is available for grouting. Allow bond coat to cure. Force grout into the joints with a rubber grout float. Make sure all joints are well-compacted and free of voids and gaps. Remove excess grout from the tile surface and clean.

#### LIMITATIONS

- Some systems may require epoxy grout and/or epoxy bond-coat.
- Some products/systems cannot be used in commercial applications where heavy loads and carts will be used. A "Light Commercial" to "Heavy Commercial" rating utilizing ASTM C-627 should be required.

#### OTHER CONSIDERATIONS

- Sound reduction membranes are intended to minimize the transfer of sound from one room to the room below, it is however only part of the overall system. Substrates, flooring material, dropped ceiling assemblies, perimeter joints, etc., will all affect the overall values.
- Movement Joint ( architect must specify type of joint and show location and details on drawings).
- Movement joints - mandatory according to Detail 301MJ-2025.
- All systems must meet or exceed a "Residential Rating" with ASTM C627.
- Some systems require 2 layers of 15 mm type X Gypsum Ceiling.
- Refer to notes on "Sound Control Underlayment" Boards.
- Ratings may vary from 64 IIC to approximately 68 IIC using ASTM E492 . depending on product and other components in the system.
- This floor assembly has little or no effect on STC rating, normally this floor assembly will have an STC of 50 or more, when the appropriate sound rated wall detail is used.
- Request for test results for ASTM E-2179-03 from manufacturer to determine contribution on a concrete slab. Product specified should have a contribution ( $\Delta$ ) IIC rating of 10 or greater.

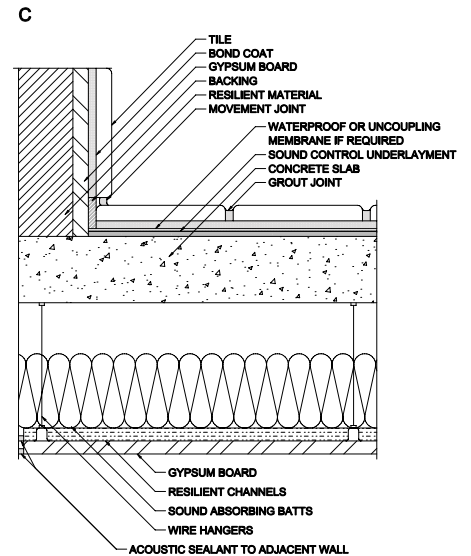

Continued

# SOUND CONTROL SYSTEMS ON INTERIOR FLOORS

## 331F-SC-2025

### DETAIL D – THICK SYSTEM ON CONCRETE WITH DROPPED CEILING

#### SUITABLE SUBSTRATES

- Interior concrete slabs. Floor systems over which the tile is installed shall be in conformance with the Canadian National Building Code 2015 and applicable local building codes taking into consideration anticipated live and dead loads.

#### MATERIALS

- SOUND REDUCTION MEMBRANE – as per manufacturer's recommendations. A wide range of resilient material can be used including crumbled rubber, cork, foam and other resilient materials.
- BOND COAT – Dry-set mortar (minimum acceptable standard ANSI A118.1 or ISO 13007 C1), latex-Portland cement mortar (minimum acceptable standard ANSI A118.4 or ISC 13007 C2), modified epoxy emulsion mortars or 100% solids epoxy mortar (minimum acceptable standard ANSI A118.3 or ISO 13007 R1).
- GROUT – Portland cement, latex-Portland cement (minimum acceptable standard ANSI A118.6 or ISC 13007 CG1) or epoxy (minimum acceptable standard ANSI A118.3 or ISO 13007 RG), or RTU grout.
- GYPSUM BOARD – ASTM C36 Type X 15 mm-thick.
- RESILIENT CHANNELS – 1 or 2 legged.
- SOUND ABSORBANT BATT – Fibreglass batt, natural cotton fibre or other.
- ACCOUSTIC SEALANT – ASTM C919.

#### APPLICATION

- Apply sound reduction membrane following manufacturer's recommendations to provide complete coverage of the substrate.
- Apply mortar bed (see Tile Guide Specification Section Mixes 2.9.2.5) to required thickness over fresh slurry bond coat (see Tile Guide Specification Section Mixes 2.9.2.2). Finished tolerance of mortar bed not to exceed 6 mm in 3000 mm or 2 mm in 300 mm.
- All perimeters must be recessed away from the walls and acoustic sealant or refabricated movement joints must be applied. Use proper notched trowel to ensure adequate bond. With pressure, apply a coat of mortar by using the trowel's flat side to key the mortar into the substrate. Apply additional mortar, combing it in a single direction parallel to the tile's shortest dimension, with the trowel's notched side. Place the tiles firmly into the wet bond coat. Push the tiles back and forth in a direction perpendicular to trowel lines, to collapse the mortar ridges and to help achieve maximum coverage. Ensure proper contact between mortar, tile and substrate by periodically lifting a few tiles to check for acceptable coverage. Use sufficient bond coat to ensure minimum 80% contact to the back of the tile with back of tile. For tile with any edge longer than 380 mm use sufficient bond coat to ensure minimum 95% contact, with the corners and edges fully supported. Remove excess mortar from the joint areas so that at least 2/3 of the tile depth is available for grouting. Allow bond coat to cure. Force grout into the joints with a rubber grout float. Make sure all joints are well-compacted and free of voids and gaps. Remove excess grout from the tile surface and clean.

#### LIMITATIONS

- Some products/systems cannot be used in commercial applications where heavy loads and carts will be used. A "Light Commercial" to "Heavy Commercial" rating utilizing ASTM C627 should be required.
- This assembly will normally raise the floor from anywhere from 30 mm to 62.5 mm in height. Height restrictions should be evaluated.

#### OTHER CONSIDERATIONS

- Sound reduction membranes are intended to minimize the transfer of sound from one room to the room below, it is however only part of the overall system. Substrates, flooring material, dropped ceiling assemblies, perimeter joints, etc., will all affect the overall values.
- Movement Joint (architect must specify type of joint and show location and details on drawings).
- Movement joints - mandatory according to Detail 301MJ-2019-2021.
- All systems must meet or exceed a "Residential Rating" with ASTM C627.
- Some systems require 2 layers of 15 mm type X Gypsum Ceiling.
- Refer to notes on "Sound Control Underlayment" Boards.
- Ratings may vary from 65 IIC to approximately 70 IIC using ASTM E492.
- This floor assembly has little or no effect on STC rating, normally this floor assembly will have an STC of 50 or more, when the appropriate sound rated wall detail is used.
- Request for test results for ASTM E-2179-03 from manufacturer to determine contribution on a concrete slab. Product specified should have a contribution ( $\Delta$ ) IIC rating of 10 or greater.
- Detail 314F-G Modular Screed System on concrete can be used as alternative to a monolithic mortar bed.

Continued

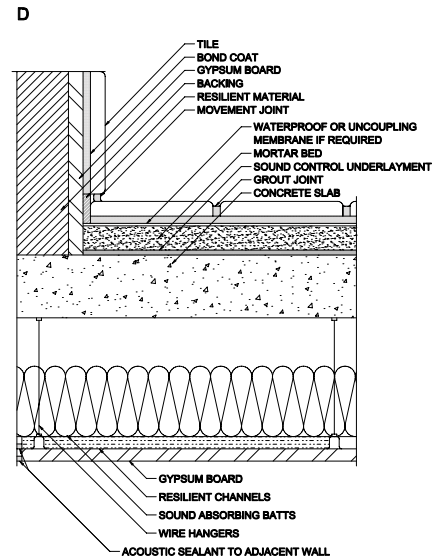

# ✿ SOUND CONTROL SYSTEMS ON INTERIOR FLOORS

## 331F-SC-2025

### DETAIL D2 – FLOWABLE HYDRAULIC CEMENT / SELF-LEVELING UNDERLAYMENT ON CONCRETE WITH DROPPED CEILING

#### SUITABLE SUBSTRATES

- Interior concrete slabs. Floor systems over which the tile is installed shall be in conformance with the Canadian National Building Code 2015 and applicable local building codes taking into consideration anticipated live and dead loads.

#### MATERIALS

- PRIMER – per manufacturer’s recommendations
- LATH - Galvanized wire lath not less than 1.4 kg/m<sup>2</sup> meeting ASTM C847 or equivalent plastic lath meeting ASTM C1764.
- FHCU /SLU – Meeting ANSI A118.16
- BONDED SOUND REDUCTION MEMBRANE – as per manufacturer’s recommendations. A wide range of resilient material can be used including crumbled rubber, cork, foam and other resilient materials.
- BOND COAT – Dry-set mortar (minimum acceptable standard ANSI A118.1 or ISO 13007 C1), latex-Portland cement mortar (minimum acceptable standard ANSI A118.4 or ISO 13007 C2), modified epoxy emulsion mortars or 100% solids epoxy mortar (minimum acceptable standard ANSI A118.3 or ISO 13007 R1).
- GROUT – Portland cement, latex-Portland cement (minimum acceptable standard ANSI A118.6 or ISO 13007 CG1) or epoxy (minimum acceptable standard ANSI A118.3 or ISO 13007 RG), or RTU grout.
- GYPSUM BOARD – ASTM C36 Type X 15 mm-thick.
- RESILIENT CHANNELS – 1 or 2 legged.
- SOUND ABSORBANT BATT – Fibreglass batt, natural cotton fibre or other.
- ACCOUSTIC SEALANT – ASTM C919.

#### APPLICATION

- Apply primer, then attach lath to plywood. (Some underlayment formulations, including fiber-reinforced formulations, do not require lath)
- Place FHCU/SLU at thickness recommended by manufacturer, typically up to 38mm per lift and at least 13mm over lath and plywood. Finished tolerance of FHCU/SLU not to exceed 6 mm in 3000 mm or 2 mm in 300 mm.
- Apply bonded sound reduction membrane following manufacturer’s recommendations to provide complete coverage of the substrate
- Apply sound reduction membrane following manufacturer’s recommendations to provide complete coverage of the substrate.
- All perimeters must be recessed away from the walls and acoustic sealant or refabricated movement joints must be applied.
- Use proper notched trowel with bond coat to ensure adequate bond. With pressure, apply a coat of mortar by using the trowel’s flat side to key the mortar into the substrate. Apply additional mortar, combing it in a single direction parallel to the tile’s shortest dimension, with the trowel’s notched side. Place the tiles firmly into the wet bond coat. Push the tiles back and forth in a direction perpendicular to trowel lines, to collapse the mortar ridges and to help achieve maximum coverage. Ensure proper contact between mortar, tile and substrate by periodically lifting a few tiles to check for acceptable coverage. Use sufficient bond coat to ensure minimum 80% contact to the back of the tile with back of tile. For tile with any edge longer than 380 mm use sufficient bond coat to ensure minimum 95% contact, with the corners and edges fully supported. Remove excess mortar from the joint areas so that at least 2/3 of the tile depth is available for grouting. Allow bond coat to cure. Force grout into the joints with a rubber grout float. Make sure all joints are well-compacted and free of voids and gaps. Remove excess grout from the tile surface and clean.

#### LIMITATIONS

- Some products/systems cannot be used in commercial applications where heavy loads and carts will be used. A “Light Commercial” to “Heavy Commercial” rating utilizing ASTM C627 should be required.
- This assembly will normally raise the floor from anywhere from 24 mm to 62.5 mm in height. Height restrictions should be evaluated.

#### OTHER CONSIDERATIONS

- Sound reduction membranes are intended to minimize the transfer of sound from one room to the room below, it is however only part of the overall system. Substrates, flooring material, dropped ceiling assemblies, perimeter joints, etc., will all affect the overall values.
- Movement Joint (architect must specify type of joint and show location and details on drawings).
- Movement joints - mandatory according to Detail 301MJ-2019-2021.
- All systems must meet or exceed a “Residential Rating” with ASTM C627.
- Some systems require 2 layers of 15 mm type X Gypsum Ceiling.
- Refer to notes on “Sound Control Underlayment” Boards.
- Ratings may vary from 65 IIC to approximately 70 IIC using ASTM E492.
- This floor assembly has little or no effect on STC rating, normally this floor assembly will have an STC of 50 or more, when the appropriate sound rated wall detail is used.
- Request for test results for ASTM E-2179-03 from manufacturer to determine contribution on a concrete slab. Product specified should have a contribution (Δ) IIC rating of 10 or greater.

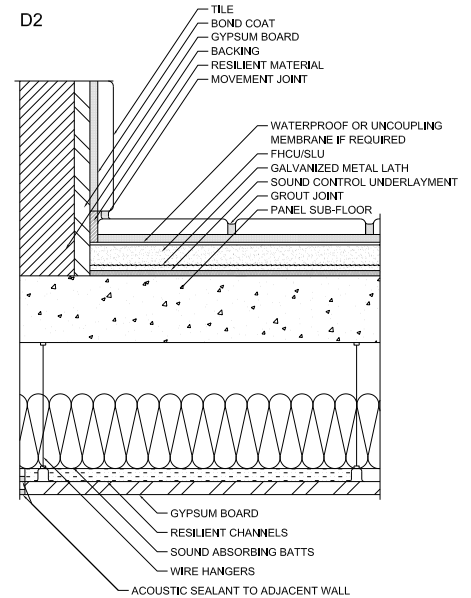

# SOUND CONTROL SYSTEMS ON INTERIOR FLOORS

## 331F-SC-2025

### DETAIL E – THIN SYSTEM ON CONCRETE NO DROPPED CEILING

#### MATERIALS

- SOUND REDUCTION MEMBRANE – meets ANSI A118.13 standard for Bonded Sound Reduction Membranes for Thin-set Ceramic Tile and Dimension Stone Installation. This standard applies to trowel applied, liquid and flexible sheet membranes.
- BOND COAT – Dry-set mortar (minimum acceptable standard ANSI A118.1 or ISO 13007 C1), latex-Portland cement mortar (minimum acceptable standard ANSI A118.4 or ISO 13007 C2), modified epoxy emulsion mortars or 100% solids epoxy mortar (minimum acceptable standard ANSI A118.3 or ISO 13007 R1).
- GROUT – Portland cement, latex-Portland cement (minimum acceptable standard ANSI A118.6 or ISO 13007 CG1) or epoxy (minimum acceptable standard ANSI A118.3 or ISO 13007 RG), or RTU grout.

#### APPLICATION

- Apply sound reduction membrane following manufacturer's recommendations to provide complete coverage of the substrate in the area on which the tile is to be installed.
- Use proper notched trowel to ensure adequate bond. With pressure, apply a coat of mortar by using the trowel's flat side to key the mortar into the substrate. Apply additional mortar, combing it in a single direction parallel to the tile's shortest dimension, with the trowel's notched side. Place the tiles firmly into the wet bond coat. Push the tiles back and forth in a direction perpendicular to trowel lines, to collapse the mortar ridges and to help achieve maximum coverage. Ensure proper contact between mortar, tile and substrate by periodically lifting a few tiles to check for acceptable coverage. Use sufficient bond coat to ensure minimum 80% contact to the back of the tile with back of tile. For tile with any edge longer than 380 mm use sufficient bond coat to ensure minimum 95% contact, with the corners and edges fully supported. Remove excess mortar from the joint areas so that at least 2/3 of the tile depth is available for grouting. Allow bond coat to cure. Force grout into the joints with a rubber grout float. Make sure all joints are well-compacted and free of voids and gaps. Remove excess grout from the tile surface and clean. All perimeters must be recessed away from the walls and acoustic sealant or prefabricated movement joints must be applied.

#### LIMITATIONS

- Some systems may require epoxy grout and/or epoxy bond-coat.
- Some products/systems cannot be used in commercial applications where heavy loads and carts will be used. A "Light Commercial" to "Heavy Commercial" rating utilizing ASTM C627 should be required.

#### OTHER CONSIDERATIONS

- Sound reduction membranes are intended to minimize the transfer of sound from one room to the room below, it is however only part of the overall system. Substrates, flooring material, dropped ceiling assemblies, perimeter joints, etc., will all affect the overall values.
- Movement Joint (architect must specify type of joint and show location and details on drawings).
- Movement joints - mandatory according to Detail 301MJ-2025.
- All systems must meet or exceed a "Residential Rating" with ASTM C627.
- Some systems require 2 layers of 15 mm type X Gypsum Ceiling.
- Refer to notes on "Sound Control Underlayment" Boards.
- Ratings may vary from 35 IIC to approximately 52 IIC using ASTM E492, depending on product and other components in the system.
- This floor assembly has little or no effect on STC rating, normally this floor assembly will have an STC of 50 or more, when the appropriate sound rated wall detail is used.
- Request for test results for ASTM E2179 from manufacturer to determine contribution on a concrete slab. Product specified should have a contribution ( $\Delta$ ) IIC rating of 20 or greater. A bare concrete slab 150 mm thick with no ceiling panels will have approximately an IIC of 28. Alternatively, a concrete slab 200 mm thick with no ceiling panels will have approximately an IIC of 32.

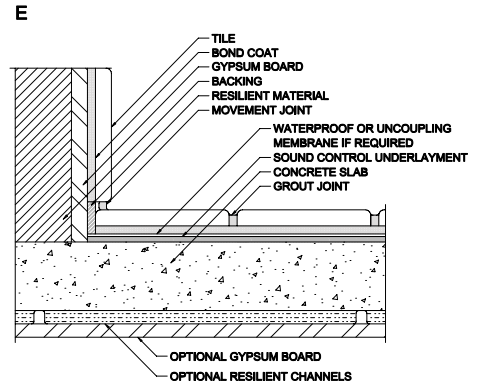

Continued

# SOUND CONTROL SYSTEMS ON INTERIOR FLOORS

## 331F-SC-2025

### DETAIL F – THICK SYSTEM ON CONCRETE NO DROPPED CEILING

#### SUITABLE SUBSTRATES

- Interior concrete slabs. Floor systems over which the tile is installed shall be in conformance with the Canadian National Building Code 2015 and applicable local building codes taking into consideration anticipated live and dead loads.

#### MATERIALS

- SOUND REDUCTION MEMBRANE – as per manufacturer’s recommendations. A wide range of resilient material can be used including crumbled rubber, cork, foam and other resilient materials.
- BOND COAT - Dry-set mortar (minimum acceptable standard ANSI A118.1 or ISO 13007 C1), latex-Portland cement mortar (minimum acceptable standard ANSI A118.4 or ISO 13007 C2), modified epoxy emulsion mortars or 100% solids epoxy mortar (minimum acceptable standard ANSI A118.3 or ISO 13007 R1).
- GROUT – Portland cement, latex-Portland cement (minimum acceptable standard ANSI A118.6 or ISC 13007 CG1) or epoxy (minimum acceptable standard ANSI A118.3 or ISO 13007 RG) or RTU grout.

#### APPLICATION

- Apply sound reduction membrane following manufacturer’s recommendations to provide complete coverage of the substrate in the area on which the tile is to be installed.
- All perimeters must be recessed away from the walls and acoustic sealant or prefabricated movement joints must be applied. Use proper notched trowel to ensure adequate bond. With pressure, apply a coat of mortar by using the trowel’s flat side to key the mortar into the substrate. Apply additional mortar, combing it in a single direction parallel to the tile’s shortest dimension, with the trowel’s notched side. Place the tiles firmly into the wet bond coat. Push the tiles back and forth in a direction perpendicular to trowel lines, to collapse the mortar ridges and to help achieve maximum coverage. Ensure proper contact between mortar, tile and substrate by periodically lifting a few tiles to check for acceptable coverage. Use sufficient bond coat to ensure minimum 80% contact to the back of the tile with back of tile. For tile with any edge longer than 380 mm use sufficient bond coat to ensure minimum 95% contact, with the corners and edges fully supported. Remove excess mortar from the joint areas so that at least 2/3 of the tile depth is available for grouting. Allow bond coat to cure. Force grout into the joints with a rubber grout float. Make sure all joints are well-compacted and free of voids and gaps. Remove excess grout from the tile surface and clean.

#### LIMITATIONS

- Some products/systems cannot be used in commercial applications where heavy loads and carts will be used. A “Light Commercial” to “Heavy Commercial” rating utilizing ASTM C627 should be required.
- This assembly will normally raise the floor from anywhere from 30 mm to 62.5 mm in height. Height restrictions should be evaluated.

#### OTHER CONSIDERATIONS

- Sound reduction membranes are intended to minimize the transfer of sound from one room to the room below, it is however only part of the overall system. Substrates, flooring material, dropped ceiling assemblies, perimeter joints, etc., will all affect the overall values.
- Movement Joint (architect must specify type of joint and show location and details on drawings)
- Movement joints - mandatory according to Detail 301MJ-2024.
- All systems must meet or exceed a “Residential Rating” with ASTM C627.
- Some systems require 2 layers of 15 mm type X Gypsum Ceiling.
- Refer to notes on “Sound Control Underlayment”.
- Ratings may vary from 40 IIC to approximately 60 IIC using ASTM E492, depending on product and other components in the system.
- This floor assembly has little or no effect on STC rating, normally this floor assembly will have an STC of 50 or more, when the appropriate sound rated wall detail is used.
- Request for test results for ASTM E2179 from manufacturer to determine contribution on a concrete slab. Product specified should have a contribution ( $\Delta$ ) IIC rating of 20 or greater. A bare concrete slab 150 mm thick with no ceiling panels will have approximately an IIC of 28. Alternatively, a concrete slab 200 mm thick with no ceiling panels will have approximately an IIC of 32.
- Detail 314F-G Modular Screed System on concrete can be used as alternative to a monolithic mortar bed.

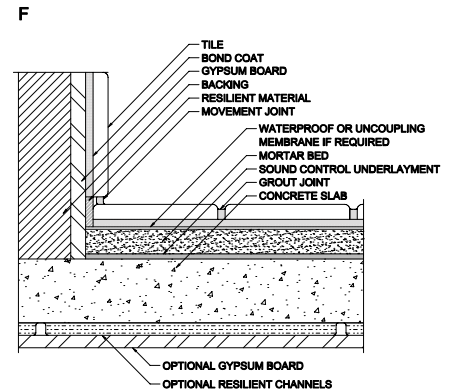

# TILE BONDED TO SUSPENDED ACCESS PANEL THIN-SET METHOD 332F-2025

## DETAIL A – INTERIOR DRY/WET

### SUITABLE SUBSTRATES

- Floor systems over which the tile will be installed shall be in conformance with the Canadian National Building Code 2015 and applicable local building codes taking into consideration anticipated live and dead loads.

### MATERIALS

- TILE – Minimum size 300 x 300 mm.
- BOND COAT – Interior: Dry-set mortar (minimum acceptable standard ANSI A118.1 or ISO 13007 C1), latex-Portland cement mortar (minimum acceptable standard ANSI A118.4 or ISO 13007 C2S1), modified epoxy emulsion mortars, 100% solids epoxy mortar, epoxy adhesive (minimum acceptable standard ANSI A118.3 or ISO 13007 R1), or organic adhesives (minimum acceptable standard ANSI A118.3 or ISO 13007 R1). Exterior: Single or two component liquid latex-Portland cement mortar (minimum acceptable standard ANSI A118.4 or ISO 13007 C2S1).
- ACCESS PANELS – 60 x 600 mm supported on all 4 corners with pedestals. Types: concrete, galvanized metal or coated metal surfaces.
- UNCOUPLING SYSTEM - to manufacturers recommendations.
- GROUT – Interior: Portland cement, latex-Portland cement (minimum acceptable standard ANSI A118.6 or ISO 13007 CG1), or epoxy grouts (minimum acceptable standard ANSI A118.3 or ISO 13007 RG).

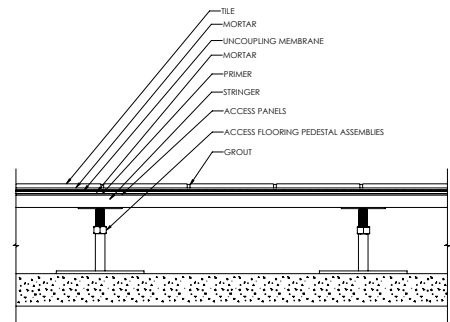

### APPLICATION

- Any leveling of the subfloor must be done prior to installing Panels must be securely fastened to properly secured pedestals to the concrete slab with adhesive or recommended fasteners by the manufacture.
- Clean and prime panel surface prior to installing. Verify that subfloor panels are properly fastened to pedestals. Cut edges of panels must be properly supported.
- Use proper notched trowel to ensure adequate bond. With pressure, apply a coat of mortar by using the trowel's flat side to key the mortar into the substrate. Apply additional mortar, combing it in a single direction parallel to the tile's shortest dimension, with the trowel's notched side. Place the tiles firmly into the wet bond coat. Push the tiles back and forth in a direction perpendicular to trowel lines, to collapse the mortar ridges and to help achieve maximum coverage. Ensure proper contact between mortar, tile and substrate by periodically lifting a few tiles to check for acceptable coverage. Use sufficient bond coat to ensure minimum 95% contact on (it may be necessary to back-butter the tile in order to meet this. Remove excess mortar from the joint areas so that at least 2/3 of the tile depth is available for grouting. Allow bond coat to cure. Force grout into the joints with a rubber grout float. Make sure all joints are well-compacted and free of voids and gaps. Remove excess grout from the tile surface and clean.

### LIMITATIONS

- Some products/systems cannot be used in commercial applications where heavy loads and carts will be used. A "Light Commercial" to "Heavy Commercial" rating utilizing ASTM C627 should be required.
- This assembly will normally raise the floor from anywhere from 150 mm to 620.5 mm in height. Height restrictions should be evaluated.

### OTHER CONSIDERATIONS

- Refer to Notes For The Professional and 301MJ-2025.
- Uncoupling Membrane – follow manufacturer's recommendations for appropriate mortars: membrane must achieve 0.3 N/mm<sup>2</sup> (50 PSI or greater) shear bond strength after 7 days per the test method in ANSI A118.12 section 5.1.3.
- For wet areas Uncoupling membrane seams and floor /wall transitions need to be sealed/ waterproofed as per the manufacturer's recommendations.
- Bond Coat to Uncoupling membrane- Dry-set mortar (minimum acceptable standard ANSI A118.1 or ISO C1, Latex Portland cement mortar (minimal acceptable standard ANSI A118.4 or ISO C2S1) or Improved Modified Dry-set.

# TILE BONDED TO SUSPENDED ACCESS PANEL THIN-SET METHOD 332F-2025

## DETAIL B – INTERIOR DRY/WET FLOWABLE HYDRAULIC CEMENT UNDERLAYMENT / SELF-LEVELING UNDERLAYMENT

### SUITABLE SUBSTRATES

- Floor systems over which the tile will be installed shall be in conformance with the Canadian National Building Code 2015 and applicable local building codes taking into consideration anticipated live and dead loads.

### MATERIALS

- TILE – No minimum size.
- PRIMER – per manufacturer's recommendations
- FHCU /SLU – Meeting ANSI A118.16
- MEMBRANE – Meeting ANSI A118.10 required in wet areas
- BOND COAT – Interior: Dry-set mortar (minimum acceptable standard ANSI A118.1 or ISO 13007 C1), latex-Portland cement mortar (minimum acceptable standard ANSI A118.4 or ISO 13007 C2S1), modified epoxy emulsion mortars, 100% solids epoxy mortar, epoxy adhesive (minimum acceptable standard ANSI A118.3 or ISO 13007 R1), or organic adhesives (minimum acceptable standard ANSI A118.3 or ISO 13007 R1). Exterior: Single or two component liquid latex-Portland cement mortar (minimum acceptable standard ANSI A118.4 or ISO 13007 C2S1).
- ACCESS PANELS – 60 x 600 mm supported on all 4 corners with pedestals. Types: concrete, galvanized metal or coated metal surfaces.
- GROUT – Interior: Portland cement, latex-Portland cement (minimum acceptable standard ANSI A118.6 or ISO 13007 CG1), or epoxy grouts (minimum acceptable standard ANSI A118.3 or ISO 13007 RG).

### APPLICATION

- Panels must be securely fastened to properly secured pedestals to the concrete slab with adhesive or recommended fasteners by the manufacture.
- Clean and prime panel surface prior to installing. Verify that subfloor panels are properly fastened to pedestals. Cut edges of panels must be properly supported.
- Use proper notched trowel with bond coat to ensure adequate bond. With pressure, apply a coat of mortar by using the trowel's flat side to key the mortar into the substrate. Apply additional mortar, combing it in a single direction parallel to the tile's shortest dimension, with the trowel's notched side. Place the tiles firmly into the wet bond coat. Push the tiles back and forth in a direction perpendicular to trowel lines, to collapse the mortar ridges and to help achieve maximum coverage. Ensure proper contact between mortar, tile and substrate by periodically lifting a few tiles to check for acceptable coverage. Use sufficient bond coat to ensure minimum 95% contact on (it may be necessary to back-butter the tile in order to meet this. Remove excess mortar from the joint areas so that at least 2/3 of the tile depth is available for grouting. Allow bond coat to cure. Force grout into the joints with a rubber grout float. Make sure all joints are well-compacted and free of voids and gaps. Remove excess grout from the tile surface and clean.

### LIMITATIONS

- Some products/systems cannot be used in commercial applications where heavy loads and carts will be used. A "Light Commercial" to "Heavy Commercial" rating utilizing ASTM C627 should be required.
- This assembly will normally raise the floor from anywhere from 150 mm to 620.5 mm in height. Height restrictions should be evaluated.

### OTHER CONSIDERATIONS

- Refer to Notes For The Professional and 301MJ-2025.
- For wet areas floor /wall transitions need to be sealed/ waterproofed as per the manufacturer's recommendations.

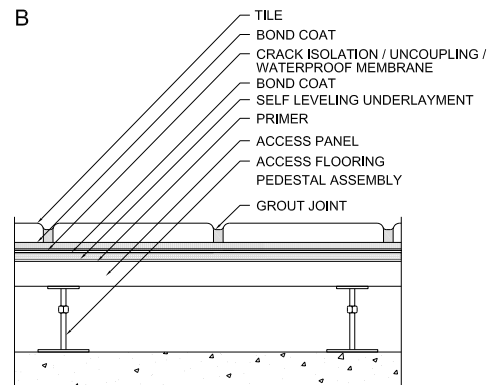

## Part 1 General

### 1.1 SUMMARY

- .1 1.1.1 This section includes requirements for supply and installation of [ceramic] [porcelain] [and] [stone] tiling and bonding systems in [floor] [wall] [and] [ceiling] configurations and includes for the following:
- 1.1.1.1 Substrate preparation
  - 1.1.1.2 Cleavage membranes for thick set materials
  - 1.1.1.3 [Crack isolation] [and] [uncoupling] membranes for [large format tiles] [suspended slabs]
  - 1.1.1.4 Waterproofing membrane for thin set tile installations
  - 1.1.1.5 Cementitious [and] [plywood] backer board[s]
  - 1.1.1.6 Tile bonding accessories including edge strips and bases [, transition strips] [, control strips] [, movement joints] [, stair treads and nosings] and other accessories required for a complete and finished installation

### 1.2 RELATED REQUIREMENTS

*SPEC NOTE: Edit following listings to reflect sections that are directly affecting or affected by work of this section. Related requirements can be used to coordinate closely related components of Work Results described in this section.*

- 1.2.1 Section 03 31 00 – Structural Concrete

*SPEC NOTE: It is highly recommended that floor flatness be specified in concrete or concrete finishing sections and to coordinate flatness tolerances required by this section prior to placement of any permanent concrete slabs*

- 1.2.2 Section 03 35 00 – Concrete Finishing
- 1.2.3 Section 05 51 00 – Metal Stairs
- 1.2.4 Section 06 10 00 – Rough Carpentry
- 1.2.5 Section 07 92 00 – Joint Seal
- 1.2.6 Section 09 21 16 – Gypsum Board Assemblies
- 1.2.7 Section 09 28 11 – Backing Boards

*SPEC NOTE: Concrete Floor Contractors Association of Canada indicates that applied finish manufacturers often employ straightedge tolerances for slab flatness that has proven not to be practical for concrete floor construction; with typical installations for slabs on grade having an FF25 or less, and most suspended slabs having an FF20 or less. Tile installations require a floor flatness in excess of FF25 to 35; listed in CSA A23.1 as a Class B Finish with increasingly flatter surfaces for larger format tile materials.*

*Since the surface flatness tolerance required to meet the straightedge requirements of most flooring materials cannot be predetermined, it is strongly advisable to include a Cash Allowance or a Unit Price Adjustment Rate to adjust quantities of floor levelling materials based on a unit prices provided by the tiling subcontractor that can be applied to the work after acceptance of the cured concrete.*

*Specifier should determine appropriate wording and pricing procedure to meet their specification requirements, and adjust the following article to suit project requirements and contract delivery methodology. Refer to NFCA guide specification available at <https://www.nfca.ca/free-resources/concrete-specification/> for recommended approach.*

### 1.3 PRICE AND PAYMENT PROCEDURES

- 1.3.1 [Allowances: Floor levelling materials specified in this Section form a part of a supply and installation cash allowance as specified in Section 01 21 00 – Allowances, and will be used to adjust material quantities where floor flatness does not meet specified requirements.]
- 1.3.2 [Unit Prices: Floor levelling materials specified in this Section form a part of a Unit Price Adjustment required by Section 00 43 [13] [23] – Procurement Submittal Form [A]; complete unit price request and submit with Bids.]

### 1.4 DEFINITIONS

- 1.4.1 Qualitative Tolerance (Straightedge): Concrete flatness based on qualitative evaluation of observed gap measured along a 3 m unlevelled straightedge placed randomly, refer to NFCA A21 for additional information.

*SPEC NOTE: Edit following listings of standards to suit project requirements, delete standards that do not apply to the Project and that are not listed in the specification after final edits. Include version of the standard including its most recent year.*

## 1.5 REFERENCE STANDARDS

### 1.5.1 American National Standards Institute (ANSI):

#### 1.5.1.1 ANSI A108.1-2021, American National Specifications for the Installation of Ceramic Tile

*SPEC NOTE: The ANSI A137.1 or ISO 10545 Ceramic Tile Standards are used to describe materials distributed in North America; the existing CAN/CGSB 75.1-M88 standard has been withdrawn by the Standards Council of Canada (SCC). TTMAC supports ISO Tile Standards in the first instance and recognizes ANSI Tile Standards where ISO is not used.*

#### 1.5.1.2 ANSI A137.1-2022, Specification for Ceramic Tile

#### 1.5.1.3 ANSI A137.2-2022, Specification for Glass Tile

#### 1.5.1.4 ANSI A137.3-2022, Specification for Gauged Porcelain Tiles and Gauged Porcelain Tile Panels/Slabs

#### 1.5.1.5 ANSI A138.1-2011(R2021), Green Squared, American National Standard Specifications for Sustainable Ceramic Tiles, Glass Tiles, and Tile Installation Materials

#### 1.5.1.6 ANSI A326.3-2021, Dynamic Coefficient of Friction (DCOF) of Hard Surface Flooring Materials

### 1.5.2 American Society for Testing and Materials (ASTM):

#### 1.5.2.1 ASTM C97/C97M-18, Standard Test Methods for Absorption and Bulk Specific Gravity of Dimension Stone

#### 1.5.2.2 ASTM C144-18, Standard Specification for Aggregate for Masonry Mortar

#### 1.5.2.3 ASTM C207-24, Standard Specification for Hydrated Lime for Masonry Purposes

#### 1.5.2.4 ASTM C241/C241M-21, Standard Test Method for Abrasion Resistance of Stone Subjected to Foot Traffic

#### 1.5.2.5 ASTM C373-18(2023), Standard Test Method for Water Absorption, Bulk Density, Apparent Porosity, and Apparent Specific Gravity of Fired Whiteware Products

#### 1.5.2.6 ASTM C503/C503M-23, Standard Specification for Marble Dimension Stone

#### 1.5.2.7 ASTM C568/C568M-22, Standard Specification for Limestone Dimension Stone

#### 1.5.2.8 ASTM C615/C615M-23, Standard Specification for Granite Dimension Stone

#### 1.5.2.9 ASTM C616/C616M-22, Standard Specification for Quartz-Based Dimension Stone

#### 1.5.2.10 ASTM C627-18(2024), Standard Test Method for Evaluating Ceramic Floor Tile Installation Systems Using the Robinson Type Floor Tester

#### 1.5.2.11 ASTM C629/C629M-22, Standard Specification for Slate Dimension Stone

#### 1.5.2.12 ASTM C648-20, Standard Test Method for Breaking Strength of Ceramic Tile

#### 1.5.2.13 ASTM C847-18, Standard Specification for Metal Lath

#### 1.5.2.14 ASTM C1353-20e1, Standard Test Method for Abrasion Resistance of Dimension Stone Subjected to Foot Traffic Using a Rotary Platform, Double-Head Abraser

### 1.5.3 Canadian Standards Association (CSA):

#### 1.5.3.1 CSA A3000-18, Cementitious Materials Compendium

#### 1.5.3.2 CSA A123.3-05 (R2020), Asphalt Saturated Organic Roofing Felt

#### 1.5.3.3 CSA O121-17 (R2022), Douglas Fir Plywood

### 1.5.4 Canadian General Standards Board (CGSB):

#### 1.5.4.1 CAN/CGSB 25.20-95, Surface Sealer for Floors

#### 1.5.4.2 CAN/CGSB 51.34-2022: Vapour Retarder, Polyethylene Film for Use in Building Construction

*SPEC NOTE: CGSB 75.1-M88 has been withdrawn by the Standards Council of Canada (SCC), most ceramic tile offered in Canada are listed under the ANSI A137.1 or ISO 10545 Standards for Ceramic Tile. Ceramic tiles should be described by manufacturer's using the ISO or ANSI designations; however, older product data may still list their products using the CGSB standard.*

#### 1.5.4.3 [CAN/CGSB 75.1-M88 Tile Ceramic]

### 1.5.5 [International Standards Organization (ISO):

#### 1.5.5.1 ISO 10545-Standards, Ceramic Tiles, Standards for Testing

#### 1.5.5.2 ISO 13006-2018, Ceramic Tiles, Definitions, Classifications, Characteristics and Marking]

#### 1.5.5.3 ISO 13007, Ceramic tiles — Grouts and adhesives

- 1.5.6 National Floor Covering Association (NFCA):
  - 1.5.6.1 A21 – Best Practices for Measuring Substrate Flatness for Floor Covering Installations
- 1.5.7 Terrazzo, Tile and Marble Association of Canada (TTMAC):
  - 1.5.7.1 TTMAC 2024-2026 Specification Guide 09 30 00, Tile Installation Manual
  - 1.5.7.2 TTMAC Dimensional Stone Guide
  - 1.5.7.3 TTMAC Hard Surface Maintenance Guide

## 1.6 ADMINISTRATIVE REQUIREMENTS

- 1.6.1 Preconstruction Meeting: Arrange a preconstruction meeting in accordance with Section [01 31 19 – Project Meetings] attended by [Constructor], Consultant, tile installer and tile supplier, mortar and grout representative [, and [[waterproof] [crack isolation] [uncoupling] [sound dampening]] membrane representative] to discuss the following:
  - 1.6.1.1 Substrate and backing surfaces flatness requirements
  - 1.6.1.2 Installation techniques associated with specified materials
  - 1.6.1.3 Compatibility between specified materials and between adjacent materials
  - 1.6.1.4 Concerns arising from site conditions
  - 1.6.1.5 Concerns of the installer or supplier arising from as-constructed conditions

*SPEC NOTE: Coordinate structural concrete drawings and design requirements for slab depressions accounting for mortar bed, bond coat and tile thicknesses and weights where finished tile floors are installed flush with adjacent floors. Coordination with the documents used for communicating construction requirements is a key success requirement to show slab depressions at drawing locations where they are most easily coordinated by the first installing subcontractor.*

- 1.6.2 Coordination: Coordinate alignment of miscellaneous specialties, fixtures and other components penetrating tiling installation is critical to final appearance of the Project:
  - 1.6.2.1 Coordinate requirements for floor recesses and provide depth of required slab depressions to Section 03 31 00 before placement of concrete accounting for mortar bed, bond coat and tile thickness where finished tile surfaces are indicated as being installed flush with adjacent floor finishes.
  - 1.6.2.2 Coordinate floor flatness and levelling requirements of this section with requirements of Section 03 35 00; work of this Section includes floor levelling and patching required to meet flooring manufacturer's installation requirements; notify Consultant where differences occur between specified tolerances and actual conditions.
  - 1.6.2.3 Coordinate with wall framing installer for appropriate offsets and blocking of framing installation to allow penetrating fixtures to centre align at intersection of tile grout lines.
  - 1.6.2.4 Coordinate with size of components penetrating tiling, and cut and shape tile products to match penetrating components:
    - 1.6.2.4.1 Site cutting will only be permitted where tiling Subcontractor can demonstrate clean cut lines and retaining remainder of tile body free from cut marks or snap lines.
    - 1.6.2.4.2 Snapped tiles reassembled around penetrating components will not be acceptable for this Project.
  - 1.6.2.5 Coordinate with Section 09 28 11 for installation of backing boards and sequence of construction for framed partitions [and ceilings].
  - 1.6.2.6 Coordinate with Section 09 21 16 for locations of tile finished partitions requiring L/360 deflection limit.
  - 1.6.2.7 [Coordinate with Section 09 21 16 for locations of tile finished ceilings requiring L/360 deflection limit.]

## 1.7 SUBMITTALS

- 1.7.1 Provide required information in accordance with Section [01 33 00 – Submittal Procedures].
- 1.7.2 Action Submittals: Provide the following submittals before starting any work of this Section:
  - 1.7.2.1 Product Data: Submit manufacturer's product data for each type of product specified; indicate compliance with specification and installation recommendations of manufacturer of products being used.

*SPEC NOTE: Shop Drawings are required only for projects where extensive or complex tile Work or unusual conditions such as may be required for swimming pools, detailed mosaics or other installations requiring special attention to details. Edit list to suit project requirements.*

1.7.2.2 Shop Drawings: Submit shop drawings indicating the following:

- 1.7.2.2.1 Tile patterns and location
- 1.7.2.2.2 Conditions affecting installation
- 1.7.2.2.3 Locations transitions and intersections between differing materials
- 1.7.2.2.4 Widths, details, and locations of [expansion and contraction joints], and [control and isolation joints] in tile substrates and finished tile surfaces
- 1.7.2.2.5 [Indicate swim lane lines and other pool markings and special patterns]
- 1.7.2.2.6 [Indicate locations and configuration of inserts and edging details]

1.7.2.3 [Samples for Initial Selection: Submit samples for initial selection by Consultant:

- 1.7.2.3.1 Tile: Manufacturer's colour charts consisting of actual tiles or sections of tiles showing the full range of colours, textures, and patterns available for each type and composition of tile indicated. Include Samples of accessories involving colour selection.
- 1.7.2.3.2 Grout: Manufacturer's colour charts consisting of actual sections of grout showing the full range of colours available for each type of grout indicated.]

*SPEC NOTE: Specify quantity and size of samples required and whether they are mounted on panels with specified grout, or submitted as individual samples.*

1.7.2.4 Samples for Verification: Submit samples for verification to Consultant including sample sets showing full range of variations expected where products involve normal colour and texture variations:

- 1.7.2.4.1 Trims: Submit full size units of each type of trim and accessory in each colour required for installation; minimum 150 mm lengths].
- 1.7.2.4.2 Tiles: Submit [one (1)] [two (2)] [four (4)] pieces of each tile [specified] [selected].

– OR –

*SPEC NOTE: Adjust panel sizes for sample submittals based on size of tiles specified; large format tiles will require larger sample panel sizes.*

- 1.7.2.4.3 Panels: Submit [300 mm x 300 mm] [900 mm x 900 mm] [600 mm x 600 mm] sized panel using [specified] [selected] material [including coloured grout] mounted on 19 mm thick plywood backer [; include sample installation of perimeter accessories, control or movement joints, and trims where applicable].

1.7.2.5 Informational Submittals: Provide the following submittals during the course of the work:

- 1.7.2.5.1 Certificates: Submit written statements from manufacturers indicating compatibility with respect to other manufacturer's materials where more than one manufacturer's products form a part of a single tile assembly.

*SPEC NOTE: Modify project sustainable design submittals to reflect actual project requirements. Choices indicated related to LEED v4.1 New Construction, always confirm credit listing based on LEED® rating system used for the Project. Confirm that specified materials qualify for sustainable design requirements before specifying them; asking for submittals for products that do not or cannot meet sustainable requirements may cause delays or additional administration to the project. Editor is responsible for coordinating appropriate submittals with article 2.3 in this Section, and Division 1 content to support the sustainability certification, program, or project goals.*

1.7.2.6 [Sustainable Design Submittals: Coordinate project sustainable design requirements with Section [01 35 31 – LEED® Special Project Procedures]; in addition, provide information for following specific DIVISION 1 requirements of this Section:]

## 1.8 PROJECT CLOSEOUT SUBMITTALS

1.8.1 Operations and Maintenance Data: Submit [two (2)] [four (4)] copies of TTMAC Hard Surface Maintenance Guide in accordance with Section [01 78 23 – Operations and Maintenance Data], and additional information as follows:

- 1.8.1.1 [Provide written literature and instructions to Owner's personnel addressing maintenance and replacement of slip resistant treatments specified in this Section.]

- 1.8.1.2 Provide specific warning of any maintenance practice or materials that may damage or disfigure the finished Work.
- 1.8.1.3 Provide manufacturer's maintenance data sheets for floor sealers and other non tile maintenance materials and accessories.
- 1.8.2 Maintenance Materials: Provide additional materials supplied to the installation in accordance with Section [01 78 43 – Spare Parts] as follows:
  - 1.8.2.1 Tile Maintenance Materials: Deliver 2% of total for each tile material used for the project, packaged neatly in original containers to prevent damage, from the same lot or batch with a minimum of [1 (one) box] [[8 (eight)] pieces] of each colour and type use for the project; clearly marked to identify the following:
    - 1.8.2.1.1 Manufacturer [, stone quarry] and distributor's name.
    - 1.8.2.1.2 Material series name and stocking number
    - 1.8.2.1.3 Material description, including colour and pattern
  - 1.8.2.2 Deliver minimum [1] [4 litre] [20 litre] container of cleaning products specified for maintenance cleaning in item 2.8.2.2 below and store as directed by Owner.

## 1.9 QUALITY ASSURANCE

- 1.9.1 [Quality Assurance Program: Communicate requirements for submission of specifications and material compatibility submissions to TTMAC as required for TTMAC Inspection; tile installation Subcontractor shall include costs for TTMAC Inspection as a part of submitted Bid.]
- 1.9.2 Qualifications: Provide proof of qualifications when requested by Consultant:
  - 1.9.2.1 Project Quality Standard: Tile Installation Manual published by the TTMAC, together with authorized additions and amendments will be used as a reference standard and forms part of this project specification.
  - 1.9.2.2 Installer: Execute Work of this Section using a company employing qualified personnel skilled in ceramic tile installation, that is a member in good standing of TTMAC at time of Bidding, having a minimum of [two (2)] [five (5)] years proven experience, and having completed tile installations similar in material, design, and extent to that indicated for this Project.
  - 1.9.2.3 Supplier: Obtain each specified material from one source with resources to provide products from the same production run for each contiguous area consistent in quality, appearance and physical properties.

## 1.10 MOCK-UPS

*SPEC NOTE: Sample installations and mock-ups are an excellent resource for communicating design intent and confirming material layouts. Dry laid sample installations are quick and easy to set up and can typically communicate design intent in an effective manner. Mock-ups are more time consuming and have a higher cost impact to the construction, but are extremely effective at confirming complex design intent and tight tolerances where there is a higher degree of expectations for the project.*

- 1.10.1 Provide required [Mock-up[s]] [Sample Installation[s]] in accordance with Section [01 45 00 – Quality Control] and as follows:
  - 1.10.1.1 [Dry lay sample installation] [Construct mock-ups] for each form of construction and finish required to verify selections made under Sample submittals and to demonstrate aesthetic effects and qualities of materials and execution.

*SPEC NOTE: Include the following where a small scale dry laid sample of representative installation may not be sufficient to confirm full aesthetic considerations or technical installation requirements.*

- 1.10.1.2 Mock-up one (1) typical [washroom] [shower room] [ ] indicating tile pattern, grout colour and accessories indicated:
  - 1.10.1.2.1 Mock-up will be used to coordinate placement of miscellaneous specialties and other related components as well as clearances to adjacent appurtenances (electrical and mechanical fixtures) and finishes.
  - 1.10.1.2.2 Consultant will require modifications pertaining to aesthetics and placement of components that interfere with other materials or fixtures.
  - 1.10.1.2.3 When identified modifications to the mock-up are completed, reviewed, and accepted by the Consultant, they will form the standard of acceptance for the remainder of the Work.

- 1.10.1.3 Locate mock-ups in the location and of the size indicated or, if not indicated, as directed by Consultant.
- 1.10.1.4 Notify Consultant seven (7) days in advance of the dates and times when mock-ups will be constructed.
- 1.10.1.5 Obtain Consultant's acceptance of mock-ups before proceeding with final unit of Work.
- 1.10.1.6 [Maintain mock-ups during construction in an undisturbed condition as a standard for judging the completed Work; demolish and remove mock-ups from Project site when directed by Consultant.] [Accepted mock-ups in an undisturbed condition at the time of Substantial Performance may become part of the completed Work.]

## 1.11 DELIVERY, STORAGE, AND HANDLING

- 1.11.1 Delivery and Acceptance Requirements: Deliver and store packaged materials in original containers with seals unbroken and labels intact until time of use in accordance with ANSI A137.1 for labelling sealed tile packages.
- 1.11.2 Storage and Handling Requirements: Store materials to prevent damage or contamination to materials by water, freezing, foreign matter, and other causes; store cementitious materials in a dry area, and blocked off floor and ground surfaces.

## 1.12 SITE CONDITIONS

- 1.12.1 Ambient Conditions: Apply tile after completion of work by other Sections is complete; to surfaces sufficiently dry, clean, firm, level, plumb and free from oil or wax or any other material harmful to tile adhesion and as follows:

*SPEC NOTE: TTMAC recommended installation temperatures for various materials are listed; always confirm with manufacturer's requirements for any variations to recommended minimum and maximums.*

- 1.12.2 Temperature: Maintain tile materials and substrate temperature between TTMAC recommended minimum and maximum temperature range; unless indicated otherwise by manufacturer, as follows:
  - 1.12.2.1 Tile and Cementitious Materials: Install tiles between [12 degrees C] and [38 degrees C], meeting installation material manufacturer's written recommendations.
  - 1.12.2.2 Epoxy Materials: Install epoxy mortar and grouts between [18 degrees C] and [35 degrees C], meeting installation material manufacturer's written recommendations.
  - 1.12.2.3 Curing Time: Maintain temperature range for 48 hours before and during installation and maintain temperature range until materials are fully set and cured in accordance with manufacturer's recommendations, and as follows:
    - 1.12.2.3.1 Provide additional heat when there is a risk that surface temperatures may drop below minimum recommended temperatures.
    - 1.12.2.3.2 Provide cooling or wait until temperature range is below maximum recommended temperatures; do not install materials when temperature is at or above maximum recommended temperature.
  - 1.12.2.4 Ventilation: Maintain adequate ventilation where Work of this Section generates toxic gases or where there is a risk of raising relative humidity to levels that could damage building finishes and assemblies.

*SPEC NOTE: Installation or product failures due to excessive amount of moisture or alkali in substrates are not the responsibility of the tile manufacturer, the tile setting system manufacturer, the supplier, or the tile contractor.*

## Part 2 Products

### 2.1 MANUFACTURERS

*SPEC NOTE: Consider the merits of Basis-of-Design Materials (single sourced materials) or Acceptable Materials (multiple sources) has on project delivery and control of aesthetic requirements. Tile finishes are more apt to be single sourced whereas accessories and setting materials can be obtained from multiple sources. Modify the content of this article as required to reflect the choices being made within the technical selection components.*

- 2.1.1 Basis-of-Design Materials: Products named [in this Section] [on Drawings] [in Finishes Legend] were used as the basis-of-design for the project; manufacturers listed as additional Acceptable Products and that offer similar products may be incorporated into the work of this Section provided they meet the performance requirements established by the named products.
- 2.1.2 Substitutions: Consultant may consider additional manufacturers having similar products to Acceptable Products Manufacturers listed above during the construction period, provided they meet the performance requirements established by the named products and provided they submit requests for substitution in accordance with Section [01 25 00 – Substitution Procedures] before starting any work of this Section:
  - 2.1.2.1 Do not use substitute materials to establish Bid Price.
  - 2.1.2.2 Substitutions that appear as a part of the project without review and acceptance by the Consultant will be rejected and replaced with one of the specified materials.
- 2.1.3 Acceptable Materials: Use any product listed where multiple products are provided in the specifications in accordance with Section [01 62 00 – Product Options] [; requests for substitutions are not required where products are available from the following:];
  - 2.1.3.1 Acceptable Tile Manufacturers: Distributors providing [ceramic] [and] [stone] materials from the following listed manufacturers are considered acceptable for use in this project:
    - 2.1.3.1.1 [List ceramic tile manufacturer by name]
    - 2.1.3.1.2 [List stone tile manufacturer by name]
    - 2.1.3.1.3 [List specific product information such as name of material, colour and product number in the form of a materials legend or schedule]
  - 2.1.3.2 Acceptable Mortar and Grout Manufacturers: Distributors providing tile mortar and grout materials from the following listed manufacturers are considered acceptable for use in this project:
    - 2.1.3.2.1 [List mortar and grout manufacturer by name]
    - 2.1.3.2.2 [List specific product information such as name of material, colour and application locations as a part of the product listings for the bonding materials]
    - 2.1.3.2.3 [ ]
  - 2.1.3.3 Additional manufacturers offering similar products may be incorporated into the work of this Section provided they meet the performance requirements established by the named products and provided they submit requests for substitution in accordance with Section [01 25 00 – Substitution Procedures] a minimum of [ten (10) days] in advance of Bid Closing.

### 2.2 PERFORMANCE REQUIREMENTS

- 2.2.1 Provide tile products manufactured and tested in accordance with ANSI A108.1 [or] [,] [ANSI A137.1] [or] ISO 10545] as appropriate to the Basis-of-Design Materials listed [in this Section] [on the Drawings] [in Finishes Legend].

*SPEC NOTE: ANSI A 326.3 replaces previous standards addressing measurement of Dynamic Coefficient of Friction (DCOF), and introduces product use categories to better capture the complexity of aligning surface characteristics with applications; refer to TTMAC Tile Installation Manual for additional information.*

- 2.2.2 Product Use Category: [Interior, Dry (ID)] [Interior, Wet (IW)] [Interior, Wet Plus (IW+)] [Exterior, Wet (EW)] [Oils/Greases (O/G)], in accordance with ANSI A 326.3.

*SPEC NOTE: Heavy Commercial Traffic porcelain tile installations should always be specified with a minimum “Extra Heavy” load rating, and will require a good quality latex modified portland cement mortar unless a membrane manufacturer requires a different mortar composition such as non-modified cementitious or epoxy. Adjust listing to reflect actual floor traffic expectations for the project; indicate on drawings where multiple load bearing performance ratings are required. Refer to TTMAC Tile Installation Manual for additional guidance for determining floor traffic requirements.*

- 2.2.3 Floor Traffic Load Bearing Performance: Provide installations rated for the following load bearing performance in accordance with ASTM C627 for ceramic tile installed on walkway surfaces:

- 2.2.3.1 Extra Heavy: Passes cycles 1 through 14
- 2.2.3.2 Heavy: Passes cycles 1 through 12
- 2.2.3.3 Moderate: Passes cycles 1 through 10
- 2.2.3.4 Light: Passes cycles 1 through 6
- 2.2.3.5 Residential: Passes cycles 1 through 3

*SPEC NOTE: ISO 10545-12 defines any tile that has 0.5% water absorption when measured using the ISO 10545-3 test as being Frost Resistant. The higher the amount of water absorption the greater the likelihood of damage caused by stress generated by freeze-thaw action.*

*Some manufacturers publish data indicating tiles having 3.0% as being frost resistant; this is not always accurate particularly for stone and quarry tile materials, always obtain proof of freeze-thaw stability for tiles having water absorption greater than 0.5%.*

*Indicate locations of frost resistant tiles on drawings where applications of frost resistant materials are limited to defined areas.*

- 2.2.4 Frost Resistance: Provide exterior tiles having a maximum water absorption rating of 0.5% or less when measured in accordance with [ASTM C373 for ceramic materials] [and] [ASTM C97 for dimensional stone] [or ISO 10545-3]; submit proof of freeze-thaw stability for tile materials having water absorption higher than 0.5%.

*SPEC NOTE: Floor flatness tolerances for large format tiles are not optional – they should be considered a mandatory preparation requirement specified in this Section. Specify starting flatness requirements in Section 03 35 00; this section will have to provide additional levelling at additional cost to the contract where the starting tolerances are not achieved, and administered as a change to the contract.*

*Concrete Floor Contractors Association of Canada (CFCA) indicates that floor flatness in the range of FF25 slabs on grade and FF20 for suspended slabs are achievable and are suitable for installation of tiles with all sides less than 380 mm; include modified flatness requirements for tile with any side greater than 380 mm and where tile manufacturers indicate a higher degree of flatness.*

*Inform structural engineer whether an entire floor areas require the tighter flatness tolerance so that they can account for additional loads and clearances required for overlayment materials. Typically where a complete overlayment is required it is better to specify a two-course slab placement and transfer responsibility to Section 03 35 00 to achieve the floor level tolerances.*

*The Constructor needs to communicate responsibilities where differences occur between the expected flatness specified in Division 03 and final flatness in Division 09 responsibilities. There are occasions where site conditions beyond the control of the concrete placement contractor can cause curling or unevenness beyond the stated tolerances and should be treated as a change to contract arising from unknown site conditions.*

- 2.2.5 Substrate and Backing Surface Flatness Tolerances: Section 03 35 00 establishes a flatness requirement for [FF25 for slabs on grade] [and] [FF20 for suspended slabs] for in place concrete and is considered as the starting flatness for work of this Section; final qualitative tolerance (straightedge) measurement for flatness and level using mortar bed or self levelling screed materials provided by this Section will be measured in accordance with NFCA A21 to achieve the following:

- 2.2.5.1 Small Format Floor Tile: Tiles having dimensions less than 100 mm x 100 mm require qualitative tolerances as follows:

2.2.5.1.1 Portland Cement Setting Beds: Maximum gap measurement of 6 mm in 3 metres.

2.2.5.1.2 Thin Set Mortar Beds: Maximum gap measurement of 6 mm in 3 metres.

2.2.5.1.3 Organic or Epoxy Adhesives: Maximum gap measurement of 4 mm in 3 metres.

- 2.2.5.2 Standard Format Floor Tile: Tiles having dimensions from 100 mm x 100 mm and tiles with all sides less than 380 mm require qualitative tolerances as follows:

2.2.5.2.1 Portland Cement Setting Beds: Maximum gap measurement of 6 mm in 3 metres.

2.2.5.2.2 Thin Set Mortar Beds: Maximum gap measurement of 5 mm in 3 metres.

2.2.5.2.3 Organic or Epoxy Adhesives: Maximum gap measurement of 2 mm in 3 metres.

- 2.2.5.3 Large Format Floor Tile: Tiles with any side greater than 380 mm require qualitative tolerance as follows:

2.2.5.3.1 Medium Set Mortar Beds: Maximum 3 mm in 3 metres, with no more than 2 gaps.

- 2.2.5.4 Wall Tiles: Provide wall levelling similar to that specified for floors for tiles having similar sizes listed above.

*SPEC NOTE: Preselect and name exact tile, stair treads and trim required wherever possible and list the manufacturer or quarry location, or both manufacturer and quarry location (if applicable); and possibly the tile distributor as Basis-of-Design Materials for the project. Alternatively it is possible to specify tile by reference standard and performance requirements based on type of manufacturing or stone, class, water absorption group, size, colour, finish, edge detail and pattern as listed in tile descriptions listed below.*

*Following descriptions include possible criteria from representative reference standards that manufacturers and suppliers could use to describe their products based on country of origin; edit paragraphs and provide descriptive criteria, limitations and reference standards to establish a minimum level of quality that manufacturers' and tile installers will be evaluated for compliance with requirements of the project.*

## 2.3 SUSTAINABILITY PERFORMANCE REQUIREMENTS

*SPEC NOTE: The following sustainability performance requirements are intentionally generic to allow modification by the editor to suit unique project requirements. These requirements can be modified to match the specific requirements of many different certification programs, or left generic for projects which are not following a certification path.*

*The following is a genericized statement of the LEED® v4.1 Material and Resources – environmental product declarations requirement. For projects using LEED® v4.1, the editor should include content in Division 1 which requires a Life Cycle Assessment (LCA) conforming to ISO 14044, or requires the use of products which have Environmental product declarations conforming to ISO 14025 and EN 15804 or ISO 21930. Confirm current LEED® credit requirements before editing this section.*

*The GREEN SQUARED program establishes approach to the evaluation and identification of environmentally preferable and sustainable ceramic tiles, glass tiles, and tile installation materials. Coordinate sustainable submittals requirements in DIVISION 1 to include ANSI A138.1 Conformance Declarations from Manufacturers. Read ANSI A138.1 for full details of the program.*

2.3.1 Provide products which meet all mandatory requirements of the GREEN SQUARED program.

*SPEC NOTE: The following is a genericized statement of the LEED® v4.1 indoor environmental quality - low-emitting materials credit. Most tile is inherently non-emitting; however, this requirement does impact the selection of grouts and sealants. For LEED® coordinate this Section with Division 1 to coordinate submittal and verification requirements. Confirm current LEED® credit requirements before editing this section.*

2.3.2 Indoor Air Quality: Provide products that mitigate the formation of mould and mildew, and that meet low-emitting materials requirements described in [Division 01]. Transport, store and handle products to further reduce conditions that are conducive to the formation of mould and mildew.

*SPEC NOTE: The following is a genericized statement of the LEED® v4.1 materials and resources – sourcing of raw materials credit. For LEED® coordinate this Section with Division 1 to coordinate submittal and verification requirements, LEED® lists specific third-party verified corporate sustainability report frameworks as acceptable to achieve project credits. Confirm current LEED® credit requirements before editing this section.*

2.3.3 Raw Materials Extraction Best Practices: Provide products that have written best practices for reduction in energy inputs throughout the manufacturing process [that can demonstrate leadership in extraction process through a third-party reporting agency] [and] [can demonstrate participation in programs showing reduction of construction waste through a material take-back program, or that report on their raw material supplies and extraction locations], and as follows:

2.3.3.1 Provide materials produced in facilities which meet the GREEN SQUARED particulate material emission criteria, and combustion criteria.

2.3.3.2 Provide materials produced by manufacturers which have a written procurement policy for immediate suppliers of raw materials which addresses social issues, environmental issues, and applicable requirements for local mining laws and regulations.

2.3.4 Recycled Content: Provide products that contain materials that are sourced from a manufacturing facility that use post-consumer, and pre-consumer recycled content, and other measures that provide a positive contribution towards the total recycle content for the project.

*SPEC NOTE: The GREEN SQUARED program calculates Total Recycled Content/Reclaimed Content = post-consumer material content + ½ pre-consumer material content + ½ reclaimed waste content. The GREEN SQUARED guide specification provides three verified levels of recycled/reclaimed content, All GREEN SQUARED verified products must meet Level 1 as a minimum, Level 3 products include the most recycled/reclaimed content. Material percentages can be calculated on either a weight or volume basis.*

2.3.4.1 Provide products which meet the GREEN SQUARED, [Level 1] [Level 2] [Level 3] requirements for Total Recycled/Reclaimed Content.

2.3.4.2 Packaging Waste Management: Remove and return to manufacturer for reuse, or remove and send to appropriate recycling facility any pallets, crates, pails, and cardboard, and other packaging materials [as described in project Waste Management Plan].

*SPEC NOTE: The GREEN SQUARED program requires that products meet .1, .2, .3, and .4, or any one of .5, .6, .7. Products meeting multiple requirements can achieve multiple credits.*

- 2.3.4.2.1 Tile: Provide products for which the packaging does not exceed 1.5% of the total weight of the product being packaged.
- 2.3.4.2.2 Dry Powdered Installation Goods (Bagged): Provide products for which the packaging does not exceed 0.8% of the total weight of the product being packaged.
- 2.3.4.2.3 Dry Powdered Installation Goods (Boxed): Provide products for which the packaging does not exceed 5.0% of the total weight of the product being packaged.
- 2.3.4.2.4 Liquid/Paste Installation Goods: Provide products for which the packaging does not exceed 83.8 kg per cubic metre of product.
- 2.3.4.2.5 Provide products in packaging which clearly outlines strategies or guidelines for on-site reuse of the packaging or responsible on-site disposal.
- 2.3.4.2.6 Provide products in packaging which is inherently biodegradable or compostable plastic in accordance with ASTM D6400. Plastic packaging coatings in accordance with ASTM D6868.
- 2.3.4.2.7 Provide products packaged using a minimum of 10% recycled material (post-consumer + ½ pre-consumer).

*SPEC NOTE: The following is a genericized statement of the LEED® v4.1 materials and resources – sourcing of raw materials credit. LEED® requires materials to be recovered and processed, and distributed and purchased within 160 km of the project site to achieve project credit. Coordinate submittal and verification requirements with Division 1. Confirm current LEED® credit requirements before editing this section.*

2.3.5 Regional Materials: Provide products that are sourced from manufacturing facilities located within regional limits described in [DIVISION 1], and as follows:

2.3.5.1 Compliance Requirement: Submit information confirming that materials were recovered and processed, and distributed and purchased within [160 km] [500 km] of the project site.

*SPEC NOTE: The GREEN SQUARED program requires that Indigenous raw materials are recovered, harvested, or extracted within a 800 km radius of the manufacturing site. Where transportation of materials by water or rail occurs, the distance travelled by that means is multiplied by 0.25 and added to the remaining distance. All GREEN SQUARED verified products must meet Level 1 requirements as a minimum, Level 3 products include the most content, on a percentage shipping weight or volume basis, which meets the Indigenous Raw Material criteria.*

2.3.5.2 Provide products which meet the GREEN SQUARED, [Level 1] [Level 2][Level 3] requirements for Indigenous Raw Material Criteria.

*SPEC NOTE: The following is a genericized statement of the LEED® v4 construction and demolition waste management planning credit. Coordinate submittal and verification requirements with Division 1. Confirm current LEED® credit requirements before editing this section.*

2.3.6 Construction Waste Reduction: Implement product ordering, handling, and onsite processing and installation methods to limit the amount of construction waste generated by this Section, and incorporate methods to collect and recycle scrap and divert from landfill to the greatest extent possible [, in accordance with waste deduction work plan described in DIVISION 1].

## 2.4 CERAMIC MATERIALS

2.4.1 Floor Tile - Type [FT1]: Provide materials meeting requirements of [ISO 13006] [ANSI A137.1] as follows:

2.4.1.1 Description:

- 2.4.1.1.1 Dimensions: Nominal [ ] mm x [ ] mm x [ ] mm thickness
- 2.4.1.1.2 Country of Origin: [List Origin]
- 2.4.1.1.3 Appearance: [Plain] [Granular] [Mottled] [Solid] [Abrasive] [Polished] [ ]
- 2.4.1.1.4 Pattern: [[Non-] Textured [slate] [stone] [random] [swirl]
- 2.4.1.1.5 Colour: [ ] [Selected from tile manufacturer's full range of [[12] [24] [36] [ ]] colours.] [As indicated [on Drawings] [in Finishes Legend]]
- 2.4.1.1.6 Glaze: [Unglazed] [Bright] [Clear] [Crystalline] [Fritted] [Mat] [Opaque] [Raw] [Semi-mat] [Speckled] [ ]

2.4.1.2 Composition: [Describe Tile Body] [Examples could include the following:]

- 2.4.1.2.1 [Porcelain [with abrasive admixture]]
- 2.4.1.2.2 [Impervious natural clay [with abrasive admixture]]
- 2.4.1.2.3 [Non-Porous Glass]

- 2.4.1.2.4 [Vitreous natural clay [with abrasive admixture]]
- 2.4.1.2.5 [Conductive]
- 2.4.1.3 Forming Method: [Pressed] [Natural Extruded] [Precision Extruded]
- 2.4.1.4 Water Absorption Class: [Less than 0.5%] [0.5% to 3.0%] [3.0% to 6.0%] [6.0% to 10.0%] [Greater than 10%] in accordance with [ASTM [C97] [C373]] [ISO 13006] [CGSB 75.1 MR [1] [2] [3] [4]]
- 2.4.1.5 Chemical Resistance: [Pass Rating [for specified application] in accordance with ISO 1054] [CR [1] [2]]
- 2.4.1.6 Frost Resistance: [Required] [Not Required]
- 2.4.1.7 Slip Resistance: [Required] [Not Required]
- 2.4.1.8 Abrasion [and Tread Wear] Resistance: Class [5 Heavy Commercial] [4 Commercial] [3 Heavy Residential] [2 Residential] [1 Light Residential] [0 Wall Tile Only] in accordance with [ISO 10545-7] [ASTM C1027]
- 2.4.1.9 Stain Resistance: Class [5 Stain Removed with Hot Water] [4 Stain Removed with Weak Cleaner] [3 Stain Removed with Strong Cleaner] [2 Stain Removed with Specific Solvents] [1 Stain not removed] in accordance with ISO 10545-14

*SPEC NOTE: Higher scratch resistance and surface abrasion resistance is denoted by higher numbers. MOH 5 or PEI 1 are not recommended for floors, and MOH 7 or PEI 5 is more suitable for high pedestrian traffic locations. Obtain advice from a knowledgeable product representative who is familiar with typical abrasion and scratch characteristics of their product line and the area of installation.*

- 2.4.1.10 Scratch Resistance: [[5] [6] [7] MOH] [PEI Rating [1] [2] [3] [4] [5] in accordance with ISO 10545-7]
  - 2.4.1.11 Break Strength: [ ] MPa in accordance with ISO 10545-4
  - 2.4.1.12 Basis-of-Design Materials: [List Manufacturer and Supplier, Material Name and other distinguishing characteristics] [As indicated [on Drawings] [in Finishes Legend]]
- 2.4.2 [Mosaic Tile - Type [MT1]: Provide materials meeting requirements of [ISO 13006] [ANSI A137.1] as follows:

*SPEC NOTE: Specify pre-spaced tile adhered to paper, open weave fabric or silicone dot mounted for areas not subjected to moisture, heavy traffic or freezing. Specify fabric or paper face mounted by means of a water-soluble adhesive for heavy traffic, freezing or other stressful environments.*

- 2.4.2.1 Description: Provide pre-spaced tile adhered to paper or open weave fabric by means of a water-soluble adhesive; materials with paper or fabric (synthetic or organic) adhered to back of tiles will be rejected, and as follows:
  - 2.4.2.1.1 Dimensions: Nominal [25] mm x [25] mm x [ ] mm thickness
  - 2.4.2.1.2 Country of Origin: [List Origin]
  - 2.4.2.1.3 Appearance: [Plain] [Granular] [Mottled] [Solid] [Abrasive] [Polished] [ ]
  - 2.4.2.1.4 Pattern: [[Non-] Textured [slate] [stone] [random] [swirl]]
  - 2.4.2.1.5 Colour: [ ] [Selected from tile manufacturer's full range of [[12] [24] [36] [ ]] colours.] [As indicated [on Drawings] [in Finishes Legend]]
  - 2.4.2.1.6 Glaze: [Unglazed] [Bright] [Clear] [Crystalline] [Fritted] [Mat] [Opaque] [Raw] [Semi-mat] [Speckled] [ ]
- 2.4.2.2 Composition: [Describe Tile Body] [Examples could include the following:
  - 2.4.2.2.1 [Porcelain [with abrasive admixture]]
  - 2.4.2.2.2 [Impervious natural clay [with abrasive admixture]]
  - 2.4.2.2.3 [Non-Porous Glass]
  - 2.4.2.2.4 [Vitreous natural clay [with abrasive admixture]]
- 2.4.2.3 Water Absorption Class: [Less than 0.5%] [0.5% to 3.0%] [3.0% to 6.0%] [6.0% to 10.0%] [Greater than 10%] in accordance with [ASTM [C97] [C373]] [ISO 13006] [CGSB 75.1 MR [1] [2] [3] [4]]
- 2.4.2.4 Chemical Resistance: [Pass Rating [for specified application] in accordance with ISO 10545] [CR [1] [2]]
- 2.4.2.5 Frost Resistance: [Required] [Not Required]
- 2.4.2.6 Slip Resistance: [Required] [Not Required]
- 2.4.2.7 Abrasion [and Tread Wear] Resistance: Class [5 Heavy Commercial] [4 Commercial] [3 Heavy Residential] [2 Residential] [1 Light Residential] [0 Wall Tile Only] in accordance with [ASTM C1027] [ISO 10545-7]
- 2.4.2.8 [Stain Resistance: Class [5 Stain Removed with Hot Water] [4 Stain Removed with Weak Cleaner] [3 Stain Removed with Strong Cleaner] [2 Stain Removed with Specific Solvents] [1 Stain not removed] in accordance with ISO 10545-14]

*SPEC NOTE: Higher scratch resistance and surface abrasion resistance is denoted by higher numbers. MOH 5 or PEI 1 are not recommended for floors, and MOH 7 or PEI 5 is more suitable for high pedestrian traffic locations. Obtain advice from a knowledgeable product representative who is familiar with typical abrasion and scratch characteristics of their product line and the area of installation.*

- 2.4.2.9 Scratch Resistance: [[5] [6] [7] MOH] [PEI Rating [1] [2] [3] [4] [5] in accordance with ISO 10545-7]
  - 2.4.2.10 [Break Strength: [ ] MPa in accordance with ISO 10545-4]
  - 2.4.2.11 Basis-of-Design Materials: [List Manufacturer and Supplier, Material Name and other distinguishing characteristics] [As indicated [on Drawings] [in Finishes Legend]]
- 2.4.3 Wall Tile - Type [WT1]: Provide materials meeting requirements of [ISO 13006] [ANSI A137.1] as follows:
- 2.4.3.1 Description:
    - 2.4.3.1.1 Dimensions: Nominal [ ] mm x [ ] mm x [ ] mm thickness
    - 2.4.3.1.2 Country of Origin: [List Origin]
    - 2.4.3.1.3 Appearance: [Plain] [Granular] [Mottled] [Solid] [Abrasive] [Polished] [ ]
    - 2.4.3.1.4 Pattern: [[Non-] Textured [slate] [stone] [random] [swirl]
    - 2.4.3.1.5 Colour: [ ] [Selected from tile manufacturer's full range of [[12] [24] [36] [ ]] colours.] [As indicated [on Drawings] [in Finishes Legend]]
    - 2.4.3.1.6 Glaze: [Unglazed] [Bright] [Clear] [Crystalline] [Fritted] [Mat] [Opaque] [Raw] [Semi-mat] [Speckled] [ ]
  - 2.4.3.2 Composition: [Describe Tile Body] [Examples could include the following:]:
    - 2.4.3.2.1 [Porcelain]
    - 2.4.3.2.2 [Impervious natural clay]
    - 2.4.3.2.3 [Non-Porous Glass]
    - 2.4.3.2.4 [Vitreous natural clay]
  - 2.4.3.3 Chemical Resistance: [Pass Rating [for specified application] in accordance with ISO 10545] [CR [1] [2]
  - 2.4.3.4 Frost Resistance: [Required] [Not Required]
  - 2.4.3.5 [Stain Resistance: Class [5 Stain Removed with Hot Water] [4 Stain Removed with Weak Cleaner] [3 Stain Removed with Strong Cleaner] [2 Stain Removed with Specific Solvents] [1 Stain not removed] in accordance with ISO 10545-14]

*SPEC NOTE: Higher scratch resistance and surface abrasion resistance is denoted by higher numbers. MOH 5 or PEI 1 are not recommended for floors, and MOH 7 or PEI 5 is more suitable for high pedestrian traffic locations. Obtain advice from a knowledgeable product representative who is familiar with typical abrasion and scratch characteristics of their product line and the area of installation.*

- 2.4.3.6 Scratch Resistance: [[5] [6] [7] MOH] [PEI Rating [1] [2] [3] [4] [5] in accordance with ISO 10545-7]
- 2.4.3.7 [Break Strength: [ ] MPa in accordance with ISO 10545-4]
- 2.4.3.8 Basis-of-Design Materials: [List Manufacturer and Supplier, Material Name and other distinguishing characteristics] [As indicated [on Drawings] [in Finishes Legend]]

*SPEC NOTE: The term quarry tile is often used colloquially as a substitute term for Porcelain or Paver Tile; quarry tile is a separate and distinct material that may require additional preparation to the surface and sealing for future maintenance. Coordinate closely with tile manufacturer and supplier.*

- 2.4.4 [Quarry Tile] [Brick Plate] - Type [FT1]: [Unglazed] [Glazed] quarry tile, [slip resistant], [square] [cushioned] [natural] [rectified] edge, conforming to referenced standards and the following:
  - 2.4.4.1 Description: [Precoat with temporary protective coating for [epoxy] [furan] grouted quarry tile and as follows:]:
    - 2.4.4.1.1 Dimensions: Nominal [ ] mm x [ ] mm x [ ] mm thickness
    - 2.4.4.1.2 Country of Origin: [List Origin]
    - 2.4.4.1.3 Face: [Plain] [Pattern]
    - 2.4.4.1.4 Colour: [ ] [Selected from tile manufacturer's full range of [[12] [24] [36] [ ]] colours.] [As indicated [on Drawings] [in Finishes Legend]]
    - 2.4.4.1.5 Glaze: [Unglazed] [Bright] [Clear] [Crystalline] [Fritted] [Mat] [Opaque] [Raw] [Semi-mat] [Speckled] [ ]
  - 2.4.4.2 Wearing Surface: [Nonabrasive] [Abrasive aggregate embedded in surface]

- 2.4.4.3 Chemical Resistance: [Pass Rating [for specified application] in accordance with ISO 10545 13]
- 2.4.4.4 Slip Resistance: [Required] [Not Required]
- 2.4.4.5 Abrasion [and Tread Wear] Resistance: Class [5 Heavy Commercial] [4 Commercial] [3 Heavy Residential] [2 Residential] [1 Light Residential] [0 Wall Tile Only] in accordance with ISO 10545-7
- 2.4.4.6 [Stain Resistance: Class [5 Stain Removed with Hot Water] [4 Stain Removed with Weak Cleaner] [3 Stain Removed with Strong Cleaner] [2 Stain Removed with Specific Solvents] [1 Stain not removed] in accordance with ISO 10545-14]
- 2.4.4.7 Scratch Resistance: [ ] MOH
- 2.4.4.8 [Break Strength: [ ] MPa in accordance with ISO 10545-4]
- 2.4.4.9 Basis-of-Design Materials: [List Manufacturer and Supplier, Material Name and other distinguishing characteristics] [As indicated [on Drawings] [in Finishes Legend]]

*SPEC NOTE: Include floor stone tiles tested in accordance with ASTM C241, minimum abrasive values are provided for each of the stones listed. Use caution when interpreting the hardness value, ASTM notes that the abrasive used for the test has changed (more aggressive) resulting in lower hardness values than indicated below – discuss values with a knowledgeable product representative.  
Abrasion Resistance Test Method C1353 will eventually replace Test Method C241. It is not necessary to perform both tests. Availability of the proper equipment and materials by the testing laboratory may determine which test is performed.*

2.4.5 Glass Tile - Type [GT1]: Provide materials meeting requirements of ANSI A137.2 as follows:

2.4.5.1 Description: Glass [mosaic] tile as follows:

- 2.4.5.1.1 Dimensions: Nominal [ ] mm x [ ] mm x [ ] mm thickness
- 2.4.5.1.2 Country of Origin: [List Origin]
- 2.4.5.1.3 Face: [Plain] [Pattern]
- 2.4.5.1.4 Colour: [ ] [Selected from tile manufacturer's full range of [[12] [24] [36] [ ]] colours.] [As indicated [on Drawings] [in Finishes Legend]]
- 2.4.5.1.5 Glaze: [Unglazed] [Bright] [Clear] [Crystalline] [Fritted] [Mat] [Opaque] [Raw] [Semi-mat] [Speckled] [ ]
- 2.4.5.2 Chemical Resistance: [Pass Rating [for specified application] in accordance with ISO 10545 13]
- 2.4.5.3 Slip Resistance: [Required] [Not Required]
- 2.4.5.4 Scratch Resistance: [5] MOH
- 2.4.5.5 Basis-of-Design Materials: [List Manufacturer and Supplier, Material Name and other distinguishing characteristics] [As indicated [on Drawings] [in Finishes Legend]]

*SPEC NOTE: Include floor stone tiles tested in accordance with ASTM C241, minimum abrasive values are provided for each of the stones listed. Use caution when interpreting the hardness value, ASTM notes that the abrasive used for the test has changed (more aggressive) resulting in lower hardness values than indicated below – discuss values with a knowledgeable product representative.  
Abrasion Resistance Test Method C1353 will eventually replace Test Method C241. It is not necessary to perform both tests. Availability of the proper equipment and materials by the testing laboratory may determine which test is performed.*

## 2.5 STONE MATERIALS

2.5.1 Granite: Provide materials meeting or exceeding requirements of ASTM C615, selected for architectural finishing [in sizes, colours and finish as indicated [on Drawings] [in Finishes Legend]] and as follows:

- 2.5.1.1 Abrasive Hardness Value: [25.0] in accordance with ASTM C241
- 2.5.1.2 Size: [ ] mm x [ ] mm x [ ] mm thickness
- 2.5.1.3 Finish: [Flamed] [Honed] [Satin Polished] [Gloss Polished]
- 2.5.1.4 Colour: [ ]
- 2.5.1.5 Basis-of-Design Materials: [List Quarry and Supplier, Material Name and other distinguishing characteristics]

*SPEC NOTE: Classification I is a less dense marble type and may be more prone to staining than Classification II marble. Class II marble is a better choice for areas that are subject to walk off and higher amount of maintenance. Some Group A marbles can be used in exterior and interior applications, use with caution for exterior applications and only where recommended by a knowledgeable product representative. Grade B and C marbles can be used for medium to light duty walking surfaces and other interior applications and other interior applications. Grade D marbles are generally used for vertical interior applications and can be used for medium to light duty walking surfaces.  
Abrasive Hardness for Marbles: 8.0 is minimum for wall stone tiles; 10.0 is suitable for light foot traffic; 12.0 and higher is suitable for commercial or institutional stairways, floor and platforms subject to heavy foot traffic.*

- 2.5.2 Marble: Provide materials meeting or exceeding requirements of TTMAC and ASTM C503, selected for architectural finish [in sizes, colours and finish as indicated [on Drawings] [in Finishes Legend] and as follows:
- 2.5.2.1 Abrasive Hardness Value: [8.0] [10.0] [12.0] in accordance with ASTM C241
  - 2.5.2.2 Classification: [I Calcite] [II Dolomite]
  - 2.5.2.3 Soundness Group [A Sound, free from spalls cracks, open seams, pits or other defects impairing structural integrity] [[B Natural Faults] [C Geological Faults] [D Maximum Faults], with flaws, voids and lines filled with polyester wax or epoxy cement]
  - 2.5.2.4 Size: [ ] mm x [ ] mm x [ ] mm thickness
  - 2.5.2.5 Finish: [Honed] [Satin Polished] [Gloss Polished]
  - 2.5.2.6 Colour: [ ]
  - 2.5.2.7 Basis-of-Design Materials: [List Quarry and Supplier, Material Name and other distinguishing characteristics]

*SPEC NOTE: Percentage of voids decreases with lowering density of the stone: low density stone weighs 1760 to 2160 kg/m<sup>3</sup>, medium density stone weighs 2160 to 2560 kg/m<sup>3</sup> and high density stone weighs more than 2560 kg/m<sup>3</sup>.*

- 2.5.3 Travertine: Provide materials meeting or exceeding requirements of ASTM C568, selected for architectural finish [in sizes, colours and finish as indicated [on Drawings] [in Finishes Legend] and as follows:
- 2.5.3.1 Abrasive Hardness Value: [10.0] in accordance with ASTM C241
  - 2.5.3.2 Classification: I Low Density
  - 2.5.3.3 Size: [ ] mm x [ ] mm x [ ] mm thickness
  - 2.5.3.4 Finish: [Honed] [Satin Polished] [Gloss Polished]
  - 2.5.3.5 Colour: [ ]
  - 2.5.3.6 Basis-of-Design Materials: [List Quarry and Supplier, Material Name and other distinguishing characteristics]
- 2.5.4 Limestone: Provide materials meeting or exceeding requirements of ASTM C568, selected for architectural finish [in sizes, colours and finish as indicated [on Drawings] [in Finishes Legend] and as follows:
- 2.5.4.1 Abrasive Hardness Value: [10.0] in accordance with ASTM C241
  - 2.5.4.2 Classification: [I Low Density] [II Medium Density] [III High Density]
  - 2.5.4.3 Size: [ ] mm x [ ] mm x [ ] mm thickness
  - 2.5.4.4 Finish: [Honed] [Satin Polished] [Gloss Polished]
  - 2.5.4.5 Colour: [ ]
  - 2.5.4.6 Basis-of-Design Materials: [List Quarry and Supplier, Material Name and other distinguishing characteristics]
- 2.5.5 Slate: Provide materials meeting or exceeding requirements of ASTM C629; selected for architectural finish [in sizes, colours and finish as indicated [on Drawings] [in Finishes Legend] and as follows:
- 2.5.5.1 Abrasive Hardness Value: [8.0] in accordance with ASTM C241
  - 2.5.5.2 Classification: [I Exterior] [and] [III Interior]
  - 2.5.5.3 Size: [ ] mm x [ ] mm x [ ] mm thickness
  - 2.5.5.4 Colour: [ ]
  - 2.5.5.5 Finish: [Honed] [Natural Cleft]
  - 2.5.5.6 Basis-of-Design Materials: [List Quarry and Supplier, Material Name and other distinguishing characteristics]

## 2.6 TRIMS AND EDGING

- 2.6.1 Trims: Provide tile trim shapes and profiles to match colour and finish of adjoining [site] [accent] tile, and as follows:
- 2.6.1.1 Size: Coordinated with sizes and coursing of adjoining flat tile where applicable.
  - 2.6.1.2 Shapes: [Bead]; [[Cove] [Universal] base]; [[surface] [double] bull nose]; [window sill]; [counter trim]; [[internal] [external] corners] [wainscot cap] [tapered transitions].
  - 2.6.1.3 Stair Nosings: Slip resistant, textured nosings.
  - 2.6.1.4 Basis-of-Design Materials: [List Manufacturer, Material Name and other distinguishing characteristics]

- 2.6.2 Straight Edge [and Transition] Strips: [Extruded [mill finished] [clear satin anodized] aluminum] [Roll formed stainless steel] [Solid brass] edge strips, [profile description]; height as required to suit tile installation; with integral perforated anchoring leg for setting the strip into the setting material and as follows:
- 2.6.2.1 Basis-of-Design Materials: [List Manufacturer, Material Name and other distinguishing characteristics]
- 2.6.3 Thresholds: [ ] marble, [ ] mm thick, [rounded edges] [bevelled [one side] [two sides]], honed finish on exposed surfaces, size to suit door opening and frame width and as follows:
- 2.6.3.1 Basis-of-Design Materials: [List Manufacturer, Material Name and other distinguishing characteristics]
- 2.6.4 Reducer Strips: purpose made metal extrusion; [stainless steel] [brass] [zinc] [anodized aluminium] type; maximum slope of 1:2 and as follows:
- 2.6.4.1 Basis-of-Design Materials: [List Manufacturer, Material Name and other distinguishing characteristics]
- 2.6.5 Prefabricated Movement Joints: purpose made, having a Shore A Hardness of 35 or greater and elasticity of plus or minus 25% when used in accordance to TTMAC Detail 301MJ and as follows:
- 2.6.5.1 Basis-of-Design Materials: [List Manufacturer, Material Name and other distinguishing characteristics]

*SPEC NOTE: Whenever possible, it is recommended the following materials are supplied by a single source manufacturer. List only materials required for the project, coordinate with setting and bonding materials manufacturers where specific installation requirements need additional detail or decision making criteria. There are additional variations to setting and grouting materials including latex additives to dry set mortars that replace water, mortars intended for installation of tile over existing tile, for rapid setting mortars, and for high humidity or shower room types of installations. It is highly recommended that the specifier confirms with manufacturer the types of materials or combinations of materials required to meet project conditions. Refer to TTMAC Tile Installation Manual for additional guidance for determining setting materials requirements based on types of installations.*

## 2.7 MORTAR, ADHESIVE AND GROUT MATERIALS

- 2.7.1 Primer: Low VOC, low viscosity primer as recommended by manufacturer to suit substrate and site conditions; provide proof of bonding ability of setting system where manufacturer recommends that a primer is not necessary to installation.

*SPEC NOTE: Specify a Levelling Bed as a minimum for all tile installations. This material is required to make up the difference between concrete levelness and levelness requirements specified in this Section. Depending on tolerances specified in Section 03 35 00, there could be spot levels in the range of 3 mm to 5 mm. Self levelling materials would only be required where extensive levelling is required and should only be used after consulting with the structural engineer.*

- 2.7.2 Surface Preparation Materials: Provide following underlayment materials:
- 2.7.2.1 Portland Cement Mortar: [Scratch [and Bond] Coat] [Levelling Bed] containing the following:
- 2.7.2.1.1 Portland Cement: Meeting or exceeding requirements of CSA A3000, Type GU
- 2.7.2.1.2 Hydrated Lime: Meeting or exceeding requirements of ASTM C207, Type [N] [NA] [S] [SA]
- 2.7.2.1.3 Sand: Meeting or exceeding requirements of ASTM C144, passing 16 mesh
- 2.7.2.1.4 Water: Potable
- 2.7.2.2 Self Levelling and Smoothing Underlayment: Cementitious self levelling smoothing underlayment meeting or exceeding requirements of ANSI A118.16, and as follows:
- 2.7.2.2.1 [Acceptable Materials: List manufacturer and product name]
- 2.7.3 Wall Tile Systems: Provide the following setting materials:
- 2.7.3.1 Thin Set Interior Installation: Dry set mortar meeting or exceeding requirements of ANSI A 118.1 formulated for thin set applications, factory sanded mortar consisting of portland cement, sand and additives requiring only addition of potable water for installation [complete with bond enhancing latex additive] and as follows:

2.7.3.1.1 [Acceptable Materials: List manufacturer and product name, and additional latex additive if required]

2.7.3.2 Thin Set Exterior Installation: Frost resistant, dry set mortar meeting or exceeding requirements of ANSI A 118.1 formulated for thin set applications with bond enhancing latex additive and as follows:

2.7.3.2.1 [Acceptable Materials: List manufacturer and product name, and additional latex additive if required]

*SPEC NOTE: Specify large and heavy tile mortar installation systems for large format tiles or tiles with irregular thickness or back surface profiles. Include reference to ANSI A118.1 for conventional ceramic materials, include reference to ANSI A118.4 for bond enhanced mortar required for porcelain materials.*

2.7.4 Floor Tile Systems: Provide the following setting materials:

2.7.4.1 [Thin] [Medium] Set Interior Installation: Latex-portland cement mortar meeting or exceeding requirements of ANSI A 118.1, rated for floor traffic load bearing performance indicated above and as follows:

2.7.4.1.1 [Acceptable Materials: List manufacturer and product name]

2.7.4.2 [Thin] [Medium] Set Exterior Installation: Frost resistant mortar setting bed exceeding the requirements of ASTM C627 for Extra Heavy installation using latex modified, portland cement mortar meeting or exceeding requirements of ANSI A 118.4 or ANSI A118.15 and as follows:

2.7.4.2.1 [Acceptable Materials: List manufacturer and product name]

*SPEC NOTE: Do not use adhesives for exterior or shower tile installations. Epoxy adhesives can be used for heavy duty chemical resistant applications such as commercial kitchens, food processing areas and restaurants. Organic adhesive are intended strictly for light duty or residential applications, such as kitchen backsplashes, tile borders and decorative inlays.*

2.7.5 Adhesive Systems: Provide the following materials:

2.7.5.1 Epoxy Adhesive: Thin set adhesive system using 100% solids epoxy resin and epoxy hardener meeting or exceeding the requirements for ANSI A108.1; stain proof, chemical resistant and having high temperature resistance and water cleanable, and as follows:

2.7.5.1.1 [Acceptable Materials: List manufacturer and product name]

2.7.5.2 Organic Adhesive: Thin set wall tile adhesive system using non-flammable, water resistant, latex adhesives for interior use meeting or exceeding requirements for ANSI A108.1, Type 1 and as follows:

2.7.5.2.1 [Acceptable Materials: List manufacturer and product name]

*SPEC NOTE: Obtain grout manufacturers' recommendations when specifying Modified Epoxy Emulsion Mortar meeting or exceeding requirements of ANSI A 118.8 or Furan Mortars and Grout meeting or exceeding requirements of ANSI A 118.5.*

2.7.6 Tile Grout Systems: Provide the following materials:

2.7.6.1 Colours: [Match colours listed named [in this Section] [on Drawings] [in Finishes Legend]] [Colours will be selected from manufacturer's [standard] [extended] range].

2.7.6.2 Unsanded Portland Cement Grout: Factory blended latex-portland cement grout meeting or exceeding requirements of ANSI A 118.6, specifically formulated for joints less than or equal to 3 mm in width and as follows:

2.7.6.2.1 [Acceptable Materials: List manufacturer and product name]

2.7.6.3 Sanded Portland Cement Grout: Factory blended dry-set stain resistant [latex modified] [commercial] portland cement and graded silica sand meeting or exceeding requirements of ANSI A 118.6, specifically formulated for joints greater than 3 mm in width and as follows:

2.7.6.3.1 [Acceptable Materials: List manufacturer and product name]

- 2.7.6.4 Polymer Modified Grout: Factory blended stain resistant polymer modified portland cement meeting or exceeding requirements of ANSI A 118.7, specifically formulated for joints greater than 3 mm in width and as follows:
- 2.7.6.4.1 [Acceptable Materials: List manufacturer and product name]
- 2.7.6.5 Epoxy Grout: Water cleanable, chemical resistant, factory blended modified portland cement compound with 100% epoxy additives and hardeners meeting or exceeding requirements of ANSI A 118.3 and as follows:
- 2.7.6.5.1 [Acceptable Materials: List manufacturer and product name]
- 2.7.6.6 Urethane Grout for Floors and Walls: Water cleanable, chemical resistant premixed urethane based sanded grout; and as follows:
- 2.7.6.6.1 [Acceptable Materials: List manufacturer and product name]
- 2.7.6.7 Silicone Acrylic grout for floors and Walls: Water cleanable, chemical resistant premixed silicone based sanded grout; and as follows:
- 2.7.6.7.1 [Acceptable Materials: List manufacturer and product name]

## 2.8 ACCESSORIES

- 2.8.1 [Wood Underlayment: [As specified in Section 06 10 00] [Provide plywood, Good-One-Side and having no knot fillers or adhesives detrimental to tiling products, minimum thickness 16 mm and meeting or exceeding requirements for Exterior Rated, Sheathing Grade square edged Douglas Fir plywood meeting or exceeding requirements of CSA O121.]]
- 2.8.2 Cleavage Membrane: [[0.10 mm] [4 mil] thick polyethylene film meeting or exceeding requirements of CAN/CGSB-51.34] [Asphalt saturated roofing felt, to CSA A123.3, Type 1].

*SPEC NOTE: Although membranes are similar in make up, they are governed by different standards; crack isolation membranes are governed by ANSI A 118.12; waterproofing membranes are governed by ANSI A 118.10 – make the appropriate choice based on installation requirements for project – substrate movements listed below are 2 mm is standard performance and 3 mm is high performance.*

- 2.8.3 [Crack Isolation] [Uncoupling Membrane] [Waterproofing] Membranes: Load bearing, [premanufactured self adhering] [liquid applied, lightweight fabric reinforced] membrane meeting requirements of ANSI [A 118.12] [A 118.10]; thickness as recommended by manufacturer to accommodate in-plane substrate movement of [2 mm] [3 mm] in thin set applications meeting or exceeding requirements of ANSI A108.1 and as follows:
- 2.8.3.1 Basis-of-Design Materials: [List Manufacturer, Material Name and other distinguishing characteristics]
- 2.8.4 [High Humidity] [Shower Room] System: Load bearing, bonded waterproof membrane and vapour retarder system in accordance with ANSI A118.10 consisting of fleece faced polypropylene membrane having a vapour permeance of 0.75 perm or less, including manufacturer's preformed corner and penetration sections; manufacturer's recommended thin set mortar and waterproofing system for tiling required for project and as follows:
- 2.8.4.1 Basis-of-Design Materials: [List Manufacturer, Material Name and other distinguishing characteristics]

*SPEC NOTE: Sound reduction membranes can be similar to crack isolation membranes, many manufacturer's provide combined products offering both crack and sound reduction properties.*

- 2.8.5 Bonded Sound attenuation Membranes: Load bearing, [premanufactured self adhering] [liquid applied, lightweight fabric reinforced] sound attenuation membrane meeting requirements of ANSI A 118.13; thickness as recommended by manufacturer to accommodate in-plane substrate movement in thin set applications meeting or exceeding requirements of ANSI A108.1 and as follows:
- 2.8.5.1 Basis-of-Design Materials: [List Manufacturer, Material Name and other distinguishing characteristics]
- 2.8.6 Foam Core Backer Units: Extruded polystyrene foam panel with integral waterproofing membrane, in accordance with ANSI A 118.18, and as follows:
- 2.8.6.1 Acceptable Materials: [List Acceptable Manufacturers, Material Names]

- 2.8.7 Cementitious Backer Units: Reinforced portland cement board, reinforcing mesh embedded near both faces in accordance with ASTM C1325 or ANSI A 118.9, and as follows:
- 2.8.7.1 Acceptable Materials: [List Acceptable Manufacturers, Material Names]
- 2.8.8 [Metal Lath: Expanded steel lath, galvanized 1.4 kg/m<sup>3</sup> meeting or exceeding requirements of ASTM C847.]
- 2.8.9 [Reinforcing Mesh: Welded wire fabric [50 x 50 mm] mesh opening, fabricated from 1.6 mm thick galvanized steel wire.]
- 2.8.10 [Latex Additive: Formulated for use in Portland cement mortars and grouts.]
- 2.8.11 Water: Potable, clean and free of chemicals and contaminants detrimental to mortar or grout mixes.
- 2.8.12 Joint Sealant: As specified in Section 07 92 00.
- 2.8.13 Sealer: Meeting or exceeding requirements of CAN/CGSB 25.20, Type [1] [2]; as recommended by tile manufacturer.

*SPEC NOTE: Porous tiles and quarry tiles may require temporary protective coatings, coordinate item 2.8.1 with 3.3.10.1 below and tile materials specified, and include only if necessary by the tile manufacturer.*

- 2.8.14 [Temporary Protective Coating: Provide material formulated to protect exposed surfaces of tile against adherence of mortar and grout; is compatible with tile, mortar, and grout products; and is easily removable after grouting is completed without damaging grout or tile:]
- 2.8.14.1 Petroleum paraffin wax, fully refined and odourless; containing at least 0.5% oil with a melting point of 49°C to 60°C.
- 2.8.14.2 Grout release in form of manufacturer's standard proprietary liquid coating that is specially formulated and recommended for use as a temporary protective coating for tile.
- 2.8.15 Tile Cleaner: A neutral cleaner capable of removing soil and residue without harming tile and grout surfaces, specifically approved for materials and installations indicated by tile and grout manufacturers and as follows:
- 2.8.15.1 Job Site Cleaner: Phosphoric acid/nitric acid based cleaning solution mixed in accordance with cleaner manufacturer's recommendations and as recommended by tile manufacturer.
- 2.8.15.2 Maintenance Cleaner: Non toxic, electrolytic, biodegradable, non ammonia containing, pH controlled cleaning solution mixed in accordance with manufacturer's recommendations.

## 2.9 MIXES

- 2.9.1 Mix premanufactured mortars and grouts in accordance with referenced standards, and mortar and grout manufacturers' written instructions; mix site mixed materials as follows:
- 2.9.1.1 Scratch Coat (by volume): Mix 1 part Portland cement, 4 parts sand, and latex additive where required by TTMAC Detail.

*SPEC NOTE: Delete following paragraph when site mixed materials are not used for the project.*

- 2.9.2 Site mix proportioned mortar and grout materials as follows:
- 2.9.2.1 Scratch Coat (by volume): Mix 1 part Portland cement, 4 parts sand, and latex additive where required by TTMAC Detail.
- 2.9.2.2 Slurry Bond Coat: Mix Portland cement and water to a creamy paste consistency. Include latex additive where required by TTMAC Detail.
- 2.9.2.3 Mortar Bed for Walls (by volume): Mix 1 part Portland cement, 4 parts sand, and [latex][ and ] [hydrated lime] additive where required by TTMAC Detail.
- 2.9.2.4 Leveling Coat (by volume): Mix 1 part Portland cement, 4 parts sand, and latex additive where required by TTMAC Detail.
- 2.9.2.5 Mortar Bed for Floors: 1 part Portland cement, 4 parts sand, and latex additive where required by TTMAC Detail; when mixed with water the mortar bed shall be of such a consistency and workability that will allow maximum compaction during tamping of the mortar bed, and achieve a minimum compressive strength of 15 MPa after 28 days. A stronger mix can be achieved by adding latex to the water
- 2.9.3 Adjust water volume depending on moisture content of sand to obtain consistency and workability.

## Part 3 Execution

### 3.1 EXAMINATION

*SPEC NOTE: It shall be the responsibility of the General Contractor or Owner or his agent to conduct adequate and definitive "moisture testing" and alkalinity testing by an independent agency in a timely manner and in accordance with the tile setting product manufacturer's literature. Results shall be deemed as acceptable by tile setting manufacturer for products specified before the installation of any tile setting system products commences.*

- 3.1.1 Testing and Inspections: [Test concrete substrates in accordance with ASTM F2170] [and] [Test moisture content of wood subfloor prior to installing resilient flooring, using electronic moisture test equipment], and as follows:
  - 3.1.1.1 Provide 72 hours notice to the Consultant of commencement of the Work.
  - 3.1.1.2 Include cost of testing as a part of the price for work of this section.
  - 3.1.1.3 [Do not install flooring over concrete slabs until slabs have cured and are sufficiently dry to bond with adhesive, as determined by flooring manufacturer's recommended bond and moisture test, and as follows:]
    - 3.1.1.3.1 Resilient flooring manufacturers generally set the maximum safe relative humidity of concrete slabs at 75% RH; confirm manufacturer's recommended relative humidity rate before starting testing.
    - 3.1.1.3.2 Moisture tests must be conducted on all concrete slabs and is especially critical where low VOC or water-based adhesives are specified.
  - 3.1.1.4 Maintain a minimum temperature of 13 degrees C for substrates during testing operations.
  - 3.1.1.5 Examine materials ordered for the project before delivering to the site; open boxes and confirm that materials match accepted samples, are free from defects and breakage detrimental to final appearance and installation, and as follows:
    - 3.1.1.5.1 Consultant will only accept Grade 1 Standard, materials appearing on site factory marked as seconds or discounted or that are not consistent with materials submitted for review will be rejected.
    - 3.1.1.5.2 Replace unacceptable materials at no additional cost to the Owner; order replacement materials using most expedient delivery method to minimize effect on construction schedule.
- 3.1.2 Examine substrates, areas, and conditions where tile will be installed for compliance with requirements for installation tolerances and other conditions affecting performance of installed tile and confirm the following:
- 3.1.3 Verify that substrates for bonding tile are firm; dry; clean; free from oil, waxy films, and curing compounds; and are within starting flatness tolerances as specified in Section 03 35 00, and are ready for application of levelling materials specified in this Section.
  - 3.1.3.1 Verify that installation of grounds, anchors, recessed frames, electrical and mechanical units of work, and similar items located in or behind tile have been completed before installing tile.
  - 3.1.3.2 Verify that joints and cracks in tile substrates are coordinated with tile joint locations; adjust joints in consultation with Consultant where joints are not coordinated.

*SPEC NOTE: Longer curing time for concrete substrates reduces the likelihood of moisture vapour emission rates that are higher than 1.45 kg/m<sup>2</sup>/24 hours; MVER testing should always be done, but is more essential for concrete that has only been placed for 28 days.*

- 3.1.3.3 Verify that concrete substrates have been allowed to cure for a minimum of [90 days] [28 days] in accordance with TTMAC requirements.
  - 3.1.3.4 Verify that tile subject to colour variations has been blended in the factory and packaged so tile units taken from one package show the same range of colours as those taken from other packages; blend tiles at site before installing if not factory blended.
  - 3.1.3.5 Verify that back of tile is free from contamination before installation.
- 3.1.4 Notify [Constructor] in writing of any conditions that are not acceptable; do not proceed with installation until unsatisfactory conditions have been corrected.

### 3.2 PREPARATION

- 3.2.1 Protection: Protect surrounding work from damage or disfiguration arising from work of this Section.
- 3.2.2 Surfaces: Thoroughly clean substrate surfaces receiving tile finishes to remove grease, oil or dust film, surface film forming concrete accessories, curing agent, and any other contaminants that may reduce adhesion within bonding systems, and as follows:

- 3.2.2.1 Clean back of each tile before installation to remove surface contaminants and cutting residue, firing release dust and other debris detrimental to bond and final surface appearance.
- 3.2.3 [Cleavage] [Crack Suppression] [Waterproofing] Membrane: Apply [cleavage] [crack suppression] [waterproofing] membrane in accordance with TTMAC and manufacturer's instructions.
- 3.2.4 Surface Levelling: Apply [Levelling Bed Mortar] [or] [Self Levelling Mortar] to make backing surfaces flat and true to tolerances in plane listed for performance requirements with additional requirements as follows:
  - 3.2.4.1 Install levelling materials wherever a slight substrate irregularity exists.
  - 3.2.4.2 Use self levelling materials for thicknesses less than 8 mm where thin set tile methods are used.
  - 3.2.4.3 Use mortar bed levelling materials for thicknesses 8 mm and greater.
  - 3.2.4.4 [Install cleavage membrane over [structural concrete slab] [suspended slabs] ]; apply 6 mm thick sand bed under cleavage membrane when membrane is applied over a rough surface].

*SPEC NOTE: SPEC NOTE: Delete the following paragraph when wood subfloors are not used; coordinate floor stiffness requirements for materials specified in Section 06 61 00.*

- 3.2.5 Securely screw underlayment to subfloor with smooth face up; space sheets 6 mm apart to allow for expansion and contraction of subfloor materials.

### 3.3 INSTALLATION

- 3.3.1 Install tiling in accordance with requirements of TTMAC Tile Installation Manual and parts of ANSI A108 Series of tile installation standards that apply to types of bonding and grouting materials, and to methods required for complete tile installation.
- 3.3.2 Extend tile work into recesses and under or behind equipment and fixtures to form a complete covering without interruptions:
  - 3.3.2.1 Terminate Work neatly at obstructions, edges, and corners without disrupting pattern or joint alignments.
  - 3.3.2.2 Make cut edges smooth, even and free from chipping.
  - 3.3.2.3 Do not split tile.
- 3.3.3 Accurately form intersections and returns; perform cutting and drilling of tile without marring visible surfaces:
  - 3.3.3.1 Cut, drill, and fit tile to accommodate work of other subcontractors penetrating or abutting work of this Section.
  - 3.3.3.2 Carefully grind cut edges of tile abutting trim, finish, or built in items for straight aligned joints.
  - 3.3.3.3 Fit tile closely to electrical outlets, piping, fixtures, and other penetrations so that plates, collars, or covers overlap tile and to provide a uniform joint appearance.
- 3.3.4 Lay tile in pattern [indicated on Drawings] [and] as follows:
  - 3.3.4.1 Align joints when adjoining tiles on floor, base, walls, and trim are the same size.
  - 3.3.4.2 Lay out tile Work and centre tile sites in both directions in each space or on each wall area.
  - 3.3.4.3 Centre tile patterns between control and movement joints; notify Consultant for further instructions where tile patterns do not align with control or movement joints.
  - 3.3.4.4 Cut tile accurately and without damage.
  - 3.3.4.5 Smooth exposed cut edges with abrasive stone, where exposed.
  - 3.3.4.6 Chipped or split edges are not acceptable.

*SPEC NOTE: Large format tile having more than 380 mm length on one side can be offset by 1/3 for broken joint patterns.*

- 3.3.4.7 Minimum tile width is [half] [one-third] unit size unless specifically indicated otherwise on Drawings.
- 3.3.4.8 Adjust tile layout to minimize tile cutting.
- 3.3.4.9 Provide uniform joint widths.
- 3.3.4.10 [Make joints between tile sheets the same width as joints within tile sheets so joints between sheets are not apparent in finished Work.]

3.3.4.11 [Slope floor tile towards floor drains in thick-bed mortar installations.]

3.3.4.12 [Lay out tile wainscots to next full tile beyond dimensions indicated.]

3.3.5 Bonding Bed: Set tile in place while bond coat is wet and tacky and as follows:

3.3.5.1 With pressure, apply a coat of mortar by using the trowel's flat side to key the mortar into the substrate. Apply additional mortar, combing it in a single direction parallel to the tile's shortest dimension, with the trowel's notched side.

3.3.5.2 Use sufficient bond coat to provide a minimum 80% contact for tiles smaller than 300 mm x 300 mm and areas having Residential or Light Load Bearing Performance requirements with bonding material evenly dispersed and pressed into back of tile; refer to back buttering requirements for larger materials and installations having Moderate or higher Load Bearing Performance requirements.

3.3.5.3 Place tiles firmly into the wet mortar. Push the tiles back and forth in a direction perpendicular to trowel lines, to collapse the mortar ridges and to help achieve maximum coverage.

3.3.5.4 Verify that corner and edges are fully supported by bonding material by periodically picking up freshly installed tile and inspecting.

3.3.5.5 Set tiles to prevent lippage greater than 1 mm over a 3 mm grout joint.

3.3.5.6 Keep two-thirds of grout joint depth free of bonding materials.

3.3.5.7 Clean excess bonding materials from tile surface prior to final set.

3.3.5.8 Sound tiles after bonding materials have cured and replace hollow sounding tile before grouting.

3.3.6 Back Buttering: Obtain 100% mortar coverage in accordance with applicable requirements for back buttering of tile in referenced TTMAC and ANSI A108 series of tile installation standards for the following applications:

3.3.6.1 Glass tile

3.3.6.2 Exterior tile

3.3.6.3 [Tile in wet areas:

3.3.6.3.1 Showers

3.3.6.3.2 Saunas

3.3.6.3.3 Tub Enclosures

3.3.6.3.4 Laundries

3.3.6.3.5 Swimming pools]

3.3.6.4 Tile installed with chemical resistant mortars and grouts

3.3.6.5 Tile having tiles 300 mm or larger in any direction

3.3.6.6 Tile having tiles with raised or textured backs

3.3.6.7 Tile having tile installation rated for Heavy or Extra Heavy Duty.

3.3.6.8 All porcelain tiles with more than 20% of the tile backs covered with firing release dust back buttered so that 100% of the back is covered with adhesive mortar rated for C627, Extra Heavy Duty rating.

3.3.7 Install prefabricated edge strips and control at locations indicated or where exposed edge of floor tile meets different flooring materials and exposed substrates.

3.3.8 Protect exposed edges of floor tile with properly sized transition strips, use sloped reducer strips where uneven transitions between 6 mm and 13 mm occur.

| Environment        | Minimum | Maximum | Joint Width   |
|--------------------|---------|---------|---------------|
| Interior/Shaded    | 4800 mm | 6100 mm | 6 mm minimum  |
| Interior/Sunlight  | 2400 mm | 3700 mm | 6 mm minimum  |
| Exterior/Normal    | 2400 mm | 3700 mm | 10 mm minimum |
| Exterior/Excessive | 2400 mm | 3000 mm | 13 mm minimum |

3.3.9 Control and Movement Joints: Install control joints and expansion joints in tile work in accordance with TTMAC Detail 301MJ; keep control and expansion joints free of bonding materials and as follows:

3.3.9.1 Cut tiles to establish line of joints; sawn joints after installation of tiles will not be acceptable to Consultant.

3.3.9.2 Locate joints in tile surfaces directly above joints in concrete substrates.

3.3.9.3 Provide floor control joints over structural control joints.

3.3.9.4 Install prefabricated joint profiles in accordance with manufacturer's written instructions, set with top surface of joint profile slightly below top surface of tile.

3.3.9.5 Prepare joints and apply sealants in accordance with requirements of Section 07 92 00.

- 3.3.9.6 Keep control and movement joints free from setting materials.
- 3.3.9.7 Form an open joint for sealant in tile wherever a change in backing material occurs, at all vertical interior corners, around penetrating pipes and fixtures, and where tile abuts other materials or fixtures.

*SPEC NOTE: Epoxy grout must be installed in a dust free environment and protected for 7 days.*

- 3.3.10 Grouting: Install grout in accordance with manufacturer's written instructions, the requirements of TTMAC, and as follows:

- 3.3.10.1 Allow proper setting time before application of grout.

*SPEC NOTE: Coordinate following item with 2.8.1 above and delete if not required. This requirement will probably be required for quarry, paver, or other tile set with, epoxy, furan or other grout that may cause staining of the tile. Delete this item if the tiles have a factory applied protective coating.*

- 3.3.10.2 [Site Applied Temporary Protective Coating: Protect exposed surfaces of tile against adherence of mortar and grout by pre coating them with a continuous film of temporary protective coating, taking care not to coat unexposed tile surfaces where required by tile manufacturer to prevent adhesion or staining of exposed tile surfaces by grout:]

- 3.3.10.2.1 Petroleum paraffin wax, applied hot.
- 3.3.10.2.2 Grout release.
- 3.3.10.2.3 Petroleum paraffin wax or grout release.

- 3.3.10.3 Force grout into the joints with a rubber grout float. Make sure all joints are well-compacted and free of voids and gaps.

- 3.3.10.4 Remove excess grout in accordance with manufacturer's written instructions and polish tile with clean cloths.

#### **3.4 SITE QUALITY CONTROL**

- 3.4.1 Inspections: Owner will pay cost of inspection of installed Work [from the cash allowance in accordance with Section [01 21 00 – Allowances]]; Subcontractor is expected to cooperate with Owner's inspector and correct deficiencies identified; inspection will consist of the following as a minimum review:

- 3.4.1.1 Arrange for mortar and grout manufacturer's representative to review delivered materials and confirm in writing that materials and mixes specified for the project are in accordance with manufacturer's requirements.
- 3.4.1.2 Confirm that tile is set flush and level with adjacent tiles.
- 3.4.1.3 Identify broken, cracked, hollow sounding or damaged tiles.
- 3.4.1.4 Confirm that accessories are installed correctly.
- 3.4.1.5 Confirm that flexible grouting and joint sealants have been installed correctly.
- 3.4.1.6 Confirm that installation is complete and in accordance with the requirements of the TTMAC.

#### **3.5 CLEANING AND PROTECTION**

- 3.5.1 Cleaning: Clean tile surfaces so they are free of foreign matter using manufacturer recommended cleaning products and methods after completion of placement and grouting and as follows:

- 3.5.1.1 Remove [latex-portland cement] [and] [epoxy] grout residue from tile as soon as possible.
- 3.5.1.2 Unglazed tile may be cleaned with acid solutions only when permitted by tile and grout manufacturer's written instructions, but no sooner than 10 days after installation; protect metal surfaces, cast iron, and vitreous plumbing fixtures from effects of acid cleaning.
- 3.5.1.3 Flush surface with clean water before and after cleaning.
- 3.5.1.4 [Remove temporary protective coating by method recommended by coating manufacturer that is acceptable to brick and grout manufacturer; trap and remove coating to prevent it from clogging drains.]

- 3.5.2 Protection: Leave finished installation clean and free of cracked, chipped, broken, unbonded, or other tile deficiencies as follows:

*SPEC NOTE: Protection times listed below account for rapid setting and standard setting mortars and grouts; adjust times to reflect materials used.*

- 3.5.2.1 Protect finished areas from traffic until setting materials have sufficiently cured in accordance with TTMAC requirements.
- 3.5.2.2 Protect floor areas from traffic after grouting is completed in accordance with manufacturer's written instructions.

- 3.5.2.3 Prevent foot and wheel traffic from floors for a minimum of [24] [72] hours after completion of grouting.
- 3.5.2.4 Use stepping boards where access is required for light foot traffic only after [4] [24] hours from completion of grouting.
- 3.5.2.5 [Do not immerse in water] [and] [protect from freezing] for a minimum of [7] [21] days after completion of tile work.
- 3.5.2.6 Provide protective covering until Substantial Performance of the Work.
- 3.5.2.7 Protect wall tiles and bases from impact, vibration, heavy hammering on adjacent and opposite walls for a minimum of [7] [14] days after installation.

### 3.6 INSTALLATION SCHEDULE

*SPEC NOTE: Specify TTMAC detail suitable for project. If more than one method applies, list conditions applicable to each detail.*

- 3.6.1 Wall Tile: TTMAC Detail [    ].
- 3.6.2 Floor Tile: TTMAC Detail [    ].
- 3.6.3 Ceiling Tile: TTMAC Detail [    ].

**END OF SECTION**

## GLOSSARY

### A

#### **Abrams law**

A rule stating that with given concrete materials and conditions of test the ratio of the amount of water to the amount of the cement in the mixture determines the strength of the concrete, provided the mixture is of a workable consistency. (See also Water cement ratio).

#### **Abrasion**

Wearing away by friction.

#### **Abrasion resistance**

Ability of a surface to resist being worn away by rubbing and friction.

#### **Absorbed moisture**

Moisture that has entered a solid material by absorption and has physical properties not substantially different from ordinary water at the same temperature and pressure. (See also Absorption.)

#### **Absorption**

The relationship of the weight of the water absorbed by a ceramic specimen subjected to prescribed immersion procedure, to the weight of the dry specimen, expressed in percent. (ASTM C242)

#### **Accelerator**

A substance which, when added to concrete, mortar, or grout, increases the rate of hydration of the hydraulic cement, shortens the time of setting, or increases the rate of hardening of strength development, or both.

#### **Accessories (Tile Accessories)**

Ceramic or non-ceramic articles, affixed to or inserted in tile work, as exemplified by towel bars, paper, soap and tumbler holders, grab bars and the like.

#### **Acid**

A chemical substance usually corrosive to common metals (iron, aluminum, zinc) and which, in water solution, imparts an acid, sour or tart taste. Acids are generally divided into two classes: (a) strong mineral or inorganic acids such as sulfamic, sulfuric, phosphoric, hydrochloric or nitric, (b) weak organic or natural acids such as acetic (vinegar), citric (citrus fruit juices), oxalic, and fatty acids (oleic, palmitic, stearic, etc.)

#### **Acid and alkali-resistant grout**

A grout that resists - Acidity. Effect of prolonged contact with acids and alkalis.

#### **Acidity**

A general term applying to substances on the acid side of neutral - principally the degree of acidity.

#### **Acrylic**

A general class of resinous polymers derived from esters, amides or other acrylic acid derivatives.

#### **Additive**

A term frequently (but improperly) used as a synonym for addition or admixture.

#### **Adhesion**

The state in which two surfaces are held together by interfacial forces which may consist of valence forces or interlocking action, or both. (See also Adhesion, mechanical and Adhesion, specific.)

#### **Adhesion mechanical**

Adhesion between surfaces in which the adhesive holds the parts together by interlocking action. (See also Adhesion, specific.)

#### **Adhesion, specific**

Adhesion between surfaces which are held together by valence forces of the same type as those which give rise to cohesion. (See also Adhesion, mechanical.)

#### **Adhesive**

A substance capable of holding materials together by surface attachment. Note: Adhesive is the general term and includes among other cement, glue, mucilage and paste. All of these terms are loosely used interchangeably. Various descriptive adjectives are applied to the term adhesive to indicate certain characteristics as follows: (a) Physical form, that is liquid adhesive, tape adhesive, (b) Chemical type, that is, silicate adhesive, resin adhesive, (c) Materials bonded, that is, paper adhesive, metal-plastic adhesive, can label adhesive, (d) Conditions of use, that is, hot-setting adhesive.

#### **Adhesive, ceramic**

Used for bonding tile to a surface. Rubber solvents; and rubber and resin-based emulsions can be used as adhesives.

#### **Adhesive, tile**

Organic adhesive used for bonding tile to a surface. Rubber solvents and resin-based and rubber emulsions can be used as adhesives.

#### **Adhesive, pressure-sensitive**

An adhesive made so as to adhere to a surface at room temperature by briefly applied pressure alone.

#### **Adhesive, solvent**

An adhesive having a volatile organic liquid as a vehicle. Note: This term excludes water based adhesives.

#### **Admixture**

A material other than water, aggregates, and hydraulic cement, used as an ingredient of concrete or mortar, and added to the concrete immediately before or during its mixing.

#### **Adobe**

Unburnt brick dried in the sun.

#### **Aggregate**

Granular material, such as sand, gravel, crushed stone, and iron blast-furnace slag, used with a cementing medium to form a hydraulic-cement, concrete or mortar. (See also Aggregate, heavyweight and Aggregate, lightweight.)

#### **Aggregate, heavyweight**

Aggregate, of high specific gravity such as barite, magnetite, limonite, ilmenite, iron or steel used to produce heavy concrete.

#### **Aggregate, lightweight**

Aggregate, of low specific gravity, such as expanded or sintered clay, shale, slate, diatomaceous shale, perlite, vermiculite, or slag; natural pumice, scoria, volcanic cinders, tuff, and diatomite; sintered fly ash or industrial cinders; used to produce lightweight concrete.

#### **Air, entrained**

See Entrained air.

#### **Air-entraining**

The capability of a material or process to develop a system of minute bubbles of air in cement, mortar, or concrete during mixing.

#### **Air-slack**

A condition where soft-body clay, after absorbing moisture and being exposed to the atmosphere, will spall a piece of clay and/or glaze.

#### **Alkali**

A chemical substance which effectively neutralizes acid material so as to form neutral salts. A base. The opposite of acid. Examples are ammonia and caustic soda.

**Alumina porcelain**

A vitreous ceramic whiteware for technical application in which alumina (A1203) is the essential crystalline phase. (ASTM C242)

**Alumina whiteware**

Any ceramic whiteware in which alumina (A1203) is the essential crystalline phase. (ASTM C242)

**Andalusite**

A polymorph, along with sillimanite and kyanite, of composition  $Al_2SiO_5$ . On firing, it dissociates to yield principally mullite. (ASTM C21)

**Anglar**

Masonry composed of squared stones; one pattern of masonry construction.

**Angle curing**

Steam curing of concrete products, sand-lime brick, asbestos-cement products, hydrous calcium silicate insulation products, or cement in an autoclave at maximum ambient temperatures generally between 176-215°C.

**Angle divider**

The angle divider is used by the tile setter to determine the degree of an angle to cut. It is used for fitting trim, moldings, and floors into corners. A corner angle is measured by adjusting the divider to fit the corner.

**ANSI**

American National Standards Institute

**Anti Fracture Membrane**

See Crack isolation.

**APA**

The Engineered Wood Association

**Apron**

Trim or facing on the side or in front of a countertop, table edge or windowsill.

**ASTM**

American Society for Testing and Materials

**Autoclave**

A pressure vessel in which an environment of steam at high pressure may be produced; used in the curing of concrete products and in the testing of hydraulic cement.

**B****Back-Butter**

The spreading of a bond coat to the backs of ceramic tile just before the tile is placed.

**Back wall**

The wall facing an observer who is standing at the entrance to a room, shower, or tub shower.

**Backing**

Any material used as a base over which ceramic tile is to be installed. See Substrate.

**Backing off**

See Feather edging tile. Angle tile.

**Balanced cuts**

Cuts of tile at the perimeter of an area that will not take full tiles. The cuts on opposite sides of such an area shall be the same size. The same sized cuts will be placed on each side of a miter.

**Ball clay**

A secondary clay, commonly characterized by the presence of organic matter, high plasticity, high dry strength, long vitrification range, and a light color when fired. (ASTM C242)

**Ball milling**

A method of grinding and mixture material, with or without liquid, in a rotating cylinder or conical mill partially filled with grinding media such as balls or pebbles. (ASTM C242)

**Bar support**

A rigid device used to support or hold reinforcing bars in proper position to prevent displacement before or during concrete placement.

**Basalt ware**

A black unglazed vitreous ceramic ware having the appearance of basalt rock. (ASTM C242)

**Base**

One or more rows of tile installed on a vertical surface above the floor. See Cove.

**Basis for acceptance**

The method of determining whether a lot of ceramic tile is acceptable under these specifications.

**Batch mixer**

A machine that mixes batches of concrete or mortar in contrast to a continuous mixer.

**Batch plant**

An operating installation of equipment including batchers and mixers as required for batching or for batching and mixing concrete materials; also called mixing plant when equipment is included.

**Beating block**

A wooden block used to embed tiles in a flat plane. The method used is called beating in.

**Belleek china**

A highly translucent whiteware composed of a body containing a significant amount of frit and normally having a luster glaze. (Produced commercially at Belleek, Ireland) (ASTM C242)

**Bench mark**

Permanent reference point or mark.

**Bentonite**

A clay composed principally of minerals of the montmorillonoid group, characterized by high absorption and very large volume change with wetting or drying. Beryllium oxide (berylla) ( $BeO$ ) An inorganic material of exceptionally high thermal conductivity which is toxic in the powder form.

**Biccottura**

Method for producing tile by firing it twice (first fire is for body, second is to fuse glazes or patterns in glaze onto the body). Usually, there are two glazes on the tile, first a non-transparent glaze on the body, then a transparent glaze on the surface.

**Biscuit chips**

Glazed-over chips on the edge or corner of the body of a tile.

**Biscuit cracks**

Any fractures in the body of a tile visible both on face and back.

**Bisque fire**

See Fire, bisque.

**Blaine fineness**

The fineness of powdered materials such as cement and pozzolans, expressed as surface area usually in square centimeters per gram, determined by the Blaine apparatus.

**Bleb**

A small blister or bubble.

**Bleeding**

The autogenous flow of mixing water within, or its emergence from newly placed concrete or mortar; caused by the settlement of the solid materials within the mass; also called water gain.

**Blend**

To mix or make homogeneous.

**Blistering**

The development during firing of enclosed or broken macroscopic vesicles or bubbles in a body, or in a glaze or other coating. (ASTM C242)

**Block angle**

A square of tile specially made for changing direction of the trim such as butterfly or down angle.

**Bloom**

A visible exudation or efflorescence on the surface.

**Blots**

Marks or stains on the face of a tile.

**Blunging**

The wet process of blending, or suspending ceramic material in liquid by agitation. (ASTM C242) The structural portion of a ceramic article. This term also refers to the material or mixture from which the article is made. (ASTM C242)

**Body**

The structural portion of a ceramic tile. This term also refers to the material or mixture from which the tile is made.

**Bond**

The adherence of one material to another.

**Bond breaker**

Any material preventing adhesion.

**Bond coat**

A material used between the back of the tile and the prepared surface. Suitable bond coats include pure Portland cement, Dry-Set Portland cement mortar, latex-type Portland cement mortar, organic adhesive, and the like.

**Bond Strength**

A bond coat's ability to resist separating from the tile and setting bed. Measured in pounds per square inch (psi).

**Bonding agent**

A substance applied to a substrate to create a bond between it and a succeeding layer. Such as between a subsurface and a terrazzo topping or a succeeding plaster application.

**Bone ash**

Calcined bone consisting essentially of calcium phosphate. (ASTM C242)

**Bone china**

A translucent china made from a ceramic whiteware body composition containing a minimum of 25 percent bone ash. (ASTM C242)

**Box Screed**

Essentially a box screed is a jig used to apply mortar onto the back side of large-sized ceramic, marble and granite tiles which may vary in thickness, in order to achieve a uniform unit of thickness of the tile and mortar combined.

**Brick trowel**

The brick trowel is larger than the buttering trowel. The most popular size used by tile setters is 125 mm-wide and 280 mm-long. It is used when any preparatory brick work has to be done. Some tile setters use it for quarry and terracotta tile work. Its greater surface and weight are advantageous in the buttering and tapping in of the larger tiles.

**Brick Veneer Tile**

Tile produced by several methods to simulate the appearance of brick.

**Bridge**

A straightedge used as a starting line for the laying of tile. The straightedge can be blocked up to support tile over an opening.

**Bridge deck**

The slab or other structure forming the travel surface of a bridge.

**Bright glaze**

Colorless or colored ceramic glaze having high gloss. (ASTM C242)

**Broom finish**

The surface texture obtained by stroking a broom over freshly placed concrete. (See also Brushed surface.)

**Brown coat**

The second coat in three-coat plaster application.

**Brushed surface**

A sandy texture obtained by brushing the surface of freshly placed or slightly hardened concrete with a stiff brush for architectural effect or, in pavements, to increase skid resistance. (See also Broom finish.)

**Building official**

The official charged with administration and enforcement of the applicable building code or his duly authorized representative.

**Bulking**

Increase in the bulk volume of a quantity of sand in a moist or wet condition over the volume of the same quantity of dry sand.

**Bulking curve**

Graph of change in volume of a quantity of sand due to change in moisture content.

**Bulking factor**

Ratio of the volume of moist sand to the volume of the sand when dry.

**Bull float**

A tool comprising a large, flat, rectangular piece of wood, aluminum, or magnesium usually 20 cm wide and 100 to 150 cm long, and a handle 1.2 m to 4.8 m in length used to smooth unformed surfaces of freshly placed concrete.

**Bullnose**

A trim tile with a convex radius on one edge. This tile is used for finishing the top of a wainscot or for turning an outside corner.

**Bullnose corner**

A type of bullnose trim with a convex radius on two adjacent edges.

**Burlap**

A coarse fabric of jute, hemp, or less commonly, flax, for use as a water-retaining covering in curing concrete surfaces; also called Hessian.

**Bushhammer**

A hammer that has a rectangular head with serrated or jagged faces. The bushhammer is used for roughing concrete to provide a bond for masonry.

**Butterfly**

A slang term for corner angles for trim shapes such as AB 106, AF 105, AF 200, AK106, and AU 106.

**Butt joint**

A plain square joint between two members.

**Butterfly**

A term commonly used for inside corner angles for trim shapes such as AB 106, AF 105, AF 200, AK 106, and AU 106.

**Buttering**

The spreading of a bond coat (followed by a mortar coat, a thin-setting bed mortar, or an organic adhesive) to the backs of ceramic tile just before the tile is placed.

**Buttonback Tile**

Tile that have projections on the bondable side. Many of these projections are round and therefore the term buttonback. Some projections are quite thick and can also be other shapes, such as square.

**C****Calcine**

A ceramic mineral or mixture fired to less than fusion for use as a constituent in a ceramic composition. (ASTM C242)

**Camber**

A deflection that is intentionally built into a structural element or form to improve appearance or to nullify the deflection of the element under the effects of loads, shrinkage and creep.

**Cap**

See Bullnose.

**Cassiterite (Sri 02)**

An inorganic mineral of the tetragonal form used as a source of tin and tin oxide. (ASTM C21)

**Cast-in-place**

Mortar or concrete which is deposited in the place where it is required to harden as part of the structure, as opposed to precast concrete.

**Casting**

Forming ceramic ware by introducing a body slip into a porous mold which absorbs sufficient water from the slip to produce a semi rigid article. (ASTM C242)

**Casting plaster**

A fast-setting gypsum plaster that is used to anchor marble to walls, set spots, or mix temporary "hot mud."

**Casting solid**

Forming ceramic ware by introducing a body slip into a porous mold which usually consists of two major sections, one section forming the contour of the inside of the ware and allowing a solid cast to form between the two mold faces. (ASTM C242)

**Casting, drain (hollow casting)**

Forming ceramic ware by introducing a body slip into an open porous mold, and then draining off the remaining slip when the cast has reached the desired thickness. (ASTM C242)

**Caulk**

See Sealant.

**Caulking compound**

A soft, plastic material consisting of pigment and vehicle, used for sealing joints in buildings and other structures where normal structural movement may occur. Caulking compound retains its plasticity for an extended period after application. It is available in forms suitable for application by gun and knife and in extruded preformed shapes.

**Ceiling mortar**

Extra-rich wall mortar.

**Cement**

Usually refers to Portland cement which when mixed with sand, gravel, and water forms concrete. Generally, cement is an adhesive; specifically, it is that type of adhesive which sets by virtue of a chemical reaction.

**Cement grout**

A cementitious mixture of Portland cement, sand or other ingredients and water which produces a water resistant, uniformly colored material used to fill joints between tile units.

**Cement mortar**

A cementitious mixture of Portland cement, sand or other ingredients and water which is used for bonding tile to back-up material.

**Cement Portland**

A hydraulic cement produced by pulverizing clinker consisting essentially of hydraulic calcium silicates, and usually containing one or more of the forms of calcium sulfate as an interground addition.

**Cement, white**

Portland cement which hydrates to a white paste; made from raw materials of low iron content, the clinker for which is fired by a reducing flame.

**Cement, masonry**

A hydraulic cement for use in mortars for masonry construction, containing one or more of the following materials: Portland cement, Portland blast-furnace slag cement, Portland-pozzolan cement, natural cement, slag cement or hydraulic lime; and in addition usually containing one or more materials such as hydrated lime, limestone, chalk, calcareous shell, talc, slag, or clay, as prepared for this purpose.

**Cement-body tiles**

Tiles with the body made from a mixture of sand and Portland cement. The surface may be finished with Portland cement, spheroids of marble or other materials.

**Cementitious**

Having the properties of cement.

**Centigrade**

A scale of temperature which features 0°C and 100°C as the freezing and boiling point of water respectively. To convert centigrade to Fahrenheit multiply by 1.8 and add 32, e.g., (100°Cx1.8)+32=212°F.

**Ceramic article**

An article having a glazed or unglazed body of crystalline or partly crystalline structure, or of glass, which body is produced from essentially inorganic, nonmetallic substances and either is formed from a molten mass which solidifies on cooling or is formed and simultaneously or subsequently matured by the action of the heat. (ASTM C242)

**Ceramic mosaic tile**

An unglazed tile formed by either the dust-pressed or plastic method, usually 6.4 to 9.5 mm-thick, and having a facial area of less than 6 in. and which is usually mounted on sheets approximately 0.3 by 0.6 m to facilitate setting. Ceramic mosaic tile may be of either porcelain or natural clay composition and may be either plain or with an abrasive mixture throughout. (ASTM C242)

**Ceramic paste**

A French term synonymous with "ceramic body." (ASTM C242)

**Ceramic process**

The production of articles or coatings from essentially inorganic, nonmetallic materials, the article or coating being made permanent and suitable for utilitarian and decorative purposes by the action of heat at temperatures sufficient to cause sintering, solid-state reactions, bonding, or conversion partially or wholly to the glassy state. (ASTM C242)

**Ceramic tile**

A ceramic surfacing unit, usually relatively thin in relation to facial area, made from clay or a mixture of clay; and other ceramic material, called the body of the tile, having either a "glazed" or "unglazed" face, and fired above red heat in the course of manufacture to a temperature sufficiently high to produce specific physical properties and characteristics.

**Ceramic whiteware**

A fired ware consisting of a glazed or unglazed ceramic body which is commonly white and of fine texture. This term designates such products as china, porcelain, semi vitreous ware and earthenware. (ASTM C242)

**Ceramics**

A general term applied to the art or technique of producing articles by a ceramic process, or to the articles so producing. (ASTM C242)

**Chair**

See Bar support.

**Chalk line**

Usually cotton cord coated with chalk. The cord is snapped to mark a straight line. The chalk line is used to align spots or screeds.

**Checking**

Short shallow cracks on the surface. Chemical porcelain. Vitreous ceramic whitewares used for containing, transporting, or reacting of chemicals. (ASTM C242)

**China**

A glazed or unglazed vitreous ceramic whiteware used for nontechnical purposes. This term designates such products as dinnerware, sanitary ware, and art ware when they are vitreous. (See also Bone china.) (ASTM C242)

**China process**

The method of producing glazed ware by which the ceramic body is fired to maturity, following which the glaze is applied and matured by firing at a lower temperature. (ASTM C242)

**China sanitary ware (sanitary plumbing fixtures)**

Glazed, vitrified whiteware fixtures having a sanitary service function. (ASTM C242)

**Chipped**

Caused from the same reasons as given under "pitted" or by rough handling and confined to the corners and edges of the tile.

**Chipping hammer**

The chipping hammer is a lightweight hammer that comes in a variety of sizes. The head and back can be capped with tungsten carbide for durability. It is used by the tile setter to chip excess material from the backs and edges of wall and quarry tiles, thus reducing the amount of grinding work necessary to smooth a cut.

**Chips**

The scaling or breaking off at the edges of fragments from the surface of a tile, as might result from rough handling.

**Clay**

A natural mineral aggregate, consisting essentially of hydrous aluminum silicates; it is plastic when sufficiently wetted, rigid when dried en masse, and vitrified when fired to a sufficiently high temperature. (ASTM C242)

**Clear glaze**

A colorless or colored transparent ceramic glaze. (ASTM C242)

**Cleavage membrane**

A layer of 15 lb. roofing felt, or an equivalent type of construction paper or polyethylene sheeting, used to isolate a wire reinforced mortar bed for tile from the concrete substrate. (CTI)

**Cold joint**

Any point in a tile installation where tile and setting bed have terminated and the surface has lost its plasticity before work is continued.

**Cold joint lines**

Visible lines on the surfaces of formed concrete indicating the presence of joints where one layer of concrete had hardened before subsequent concrete was placed. (See also Cold joint).

**Color**

The aspect of the appearance of an object dependent upon the spectral composition of the incident light, the spectral reflectance of transmittance of the object, and the spectral response of the observer.

**Colored grout**

Commercially prepared grout consisting of carefully graded aggregate, Portland cement, water dispersing agents, plasticizers and color fast pigments. (CTI).

**Column**

A member used primarily to support axial compression loads and with a height of at least three times its least lateral dimension.

**Compaction**

The process whereby the volume of freshly placed mortar or concrete is reduced to the minimum practical space usually by vibration, centrifugation, tamping, or some combination of these; to mold it within forms or molds and around embedded parts and reinforcement, and to eliminate voids other than entrained air.

**Composition tile**

A hard tile surfacing unit made from a mixture of chemicals. The finished surface can be the mixture of chemicals or can be marble chips to create a terrazzo finish. The unit is made hard by the set of the chemicals and the product is not fired as in the manufacture of ceramic tile. (CTI)

**Compressive strength**

The measured maximum resistance of a concrete or mortar specimen to axial loading; expressed as force per unit cross-sectional area; or the specified resistance used in design calculations, in the U.S. customary units of measure expressed in pounds per square inch (psi).

**Concrete**

A composite material which consists essentially of a binding medium within which are embedded particles or fragments of aggregate; in Portland cement concrete, the binder is a mixture of Portland cement and water.

**Concrete pump**

An apparatus which forces concrete to the placing position through a pipeline or hose. Concrete, prestressed. See Prestressed concrete. Concrete, pumped. See Pumped concrete.

**Concrete, fibrous**

Concrete containing, dispersed, randomly oriented fibers.

**Concrete, field**

Concrete delivered or mixed, placed, and cured on the job site.

**Concrete, foamed**

Concrete made very light and cellular by the addition of a prepared foam or by generation of gas within the unhardened mixture.

**Concrete, green**

Concrete which has set but not appreciably hardened.

**Concrete, lightweight**

Concrete using lightweight aggregates or combination of lightweight and normal-weight aggregates. Structural lightweight concrete air-density ranges from 85 to 115 PCF and compressive strength is in excess of 2500 PSI.

**Concrete, precast**

See Precast concrete.

**Concrete, refractory**

See Refractory concrete.

**Concrete, terrazzo**

Marble-aggregate concrete that is cast-in-place precast and ground smooth for decorative surfacing purposes on floors and walls.

**Condensation**

Usually refers to liquid drops which form when a vapor is chilled below its boiling point. Also refers to water droplets that deposit on surfaces whose temperature is below the dew point. Conductive (adj.) Having the quality or power of conducting or transmitting heat, electricity, or static electricity.

**Conductive mortar**

A tile mortar to which specific electrical conductivity is imparted through the use of conductive additives.

**Conductive tile**

Tile made from special body compositions or by methods that result in specific properties of electrical conductivity while retaining other normal physical properties of ceramic tile.

**Contaminated**

Stained tile as a result of carton and tile being saturated by moisture, oils, solvents or other materials.

**Contraction joint**

Formed, sawed, or tooled groove in a concrete structure to create a weakened plane and regulate the location or cracking resulting from the dimensional change of different parts of the structure. (See also Isolation joint.)

**Control joints**

See Contraction joint. (TCNA Handbook)

**Conventional installation**

The method of installing ceramic tile with Portland cement mortar.

**Coping**

The material or units used to form a cap or finish on top of a wall, pier, pilaster, or chimney.

**Corbel**

A projection from the face of a beam, girder, column, or wall used as a beam seat or a decoration.

**Cordierite porcelain**

A vitreous ceramic whiteware for technical application in which cordierite is the essential crystalline phase. (ASTM C242)

**Cordierite whiteware**

A ceramic whiteware in which cordierite is the essential crystalline phase. (ASTM C242)

**Corrosion**

The eating and wearing away by chemical action (pitting, rusting).

**Cove**

A trim tile unit having one edge with a concave radius. A cove is used to form a junction between the bottom wall course and the floor or to form an inside corner.

**Cove base (sanitary)**

A trim tile having a concave radius on one edge and a convex radius with a flat landing on the opposite edge. This base often is used as the only course of tile above the floor tile.

**Coverage**

A measure of the amount of material required to cover a given surface.

**Covering power**

The ability of a glaze to uniformly and completely cover the surface of the fired water. (ASTM C242)

**Crack-control reinforcement**

Reinforcement in concrete construction designed to prevent opening of cracks, often effective in limiting them to uniformly distributed small cracks.

**Cracked**

Tiles that have actually been cracked in one or more pieces usually during the beating in process of installation. These will show up as hairline cracks.

**Crack Isolation**

Prevention of transfer of cracks from the substrate through the tile or stone when substrate is subjected to horizontal movement of cracks.

**Cracks**

Hair-line fissures.

**Crawling**

A parting and contraction of the glaze on the surface of ceramic ware during drying or firing, resulting in unglazed areas bordered by coalesced glaze. (ASTM C242-58T)

**Crazing**

The cracking which occurs in fired glazes or other ceramic coatings due to critical tensile stresses. (ASTM C242)

**Creep**

Tune-dependent deformation due to sustained load.

**Crooked edges**

A curvature of the sides, either convex or concave, measured along the sides. The degree of crook is the departure from the straight line between two corners, expressed in percentage of the tile length.

**Crow hop**

A slang term used to describe tile joints that are out of alignment.

**Crystalline glaze**

Glazed tile with an extra heavy glaze produced for use on counter tops and light duty floor surfaces where abrasion or impact is not excessive. (CTI)

**CSI**

Construction Specification Institute

**CTDA**

Ceramic Tile Distributors Association

**CTEF**

Ceramic Tile Education Foundation

**CTI**

Ceramic Tile Institute

**CTIOA**

Ceramic Tile Institute of America

**Curing**

Maintenance of humidity and temperature of freshly placed concrete during some definite period following placing, casting, or finishing to assure satisfactory hydration of the cementitious materials and proper hardening of the concrete.

**Curing blanket**

A built-up covering of sacks, matting, hessian, straw, waterproof paper, or other suitable material placed over freshly finished concrete. (See also Burlap.)

**Curing compound**

A liquid that can be applied as a coating to the surface of newly placed concrete to retard the loss of water or, in the case of pigmented compounds, also to reflect heat so as to provide an opportunity for the concrete to develop its properties in a favorable temperature and moisture environment. (See also Curing.)

**Curing, electrical**

A system in which a favorable temperature is maintained in freshly-placed concrete by supplying heat generated by electrical resistance. Curing, steam. See Steam curing.

**Curling**

The distortion of an originally essentially linear or planar member into a curved shape such as the warping of a slab due to creep or to differences in temperature or moisture content in the zones adjacent to its opposite faces.

**Cushion-edged tile**

Tile on which the facial edges have a distinct curvature that result in a slightly recessed joint.

## D

### D-cracking

The progressive formation on a concrete surface of a series of fine cracks at rather close intervals, often of random patterns. Evidenced in slabs on grade by cracks paralleling edges or joints and curving across slab corners. (Also termed D-cracks and D-line cracks.)

### D-load

A constant load that in structures is due to the mass of the members, the supported structure, and permanent attachments or accessories.

### Dago float

A slang term used to describe the use of a fresh mortar screed in lieu of float strips to rod floor mortar. This method is commonly used in floor work. Terrazzo workers use this technique to align "concrete" for placement of brass or aluminum strips to the desired grade.

### Dago stick

A slang term used by tile setters when referring to a small piece of wood used to rod off mortar that has been applied to fill the holes caused by the removal of float strips.

### Darby

A hand-manipulated straightedge, usually 1 to 2.5 m long, used in the early stage leveling operations of concrete or plaster, preceding supplemental floating and finishing.

### Dash-bond coat

A thick slurry of Portland cement, Sand and water flicked on surfaces with a paddle or brush to provide a base for subsequent Portland cement plaster coats; sometimes used as a final finish on plaster.

### Deck

The form on which concrete for a slab is placed, also the floor or roof slab itself. (See also Bridge deck.)

### Deck or floor mortar

Mortar commonly used for decks or floors. It consists of sand and regular Portland cement mixed with water to a firm consistency.

### Decorated

Adorned, embellished, or made more attractive by means of color or surface detail. (ASTM C242).

### Decorating fire

See Fire, decorating.

### Decoration

See Decoration, inglaze; Decoration, overglaze; Decoration, underglaze.

### Decoration, inglaze

A ceramic decoration applied on the surface of an unfired glaze and matured with the glaze. (ASTM C242)

### Decoration, overglaze

A ceramic or metallic decoration applied and fired on the previously glazed surface of ceramic ware. (ASTM C242)

### Decoration, underglaze

A ceramic decoration applied directly on the surface of ceramic ware and subsequently covered with a transparent glaze.

(ASTM C242)

### Decorative tile

Tile with a ceramic decoration on the surface. (See heading under Decorated and Decoration.)

### Deflection

A variation in position or shape of a structure or structural element due to effects of load or volume change, usually measured as a linear deviation from an established plane rather than an angular variation.

### Deformation eutectic

See Eutectic, deformation.

### Delft ware

A calcareous earthenware having an opaque white glaze and monochrome overglaze decorations. (Originated in Delft, Holland.) (ASTM C242)

### Discoloration

Departure of color from that which is normal or desired.

### Divider strips

In terrazzo work, nonferrous metal or plastic strips of different thickness, and embedded depths usually 10 to 40 mm, used to form panels in the topping.

### Dolomite

The double carbonate of lime and magnesia having the general formula  $\text{CaCO}_3 \text{MgCA}_3$ . (ASTM C242)

### Dope coat

Neat cement applied to the setting bed.

### Double Bullnose

A type of trim with the same convex radius on two opposite sides.

### Dowel

A steel pin, commonly a plain round steel bar, which extends into two adjoining portions of a concrete construction, as at a joint in a pavement slab, so as to connect the portions and transfer shear loads. Also, as used in the construction of column and wall sections, a deformed steel reinforcing bar placed so as to transmit tension or compression as well as shear loads.

### Down Angle

Trim tile with two rounded or curved edges, which serves to finish an outside corner.

### Drain casting

See Casting, drain.

### Dry edging

Rough edges and corners of glazed ceramic ware due to insufficient glaze coating. (ASTM C242) Dry mix. See Process, dry.

### Dry pack

Concrete or mortar mixtures deposited and consolidated by dry packing.

### Dry packing

Placing of zero slump, or near zero slump, concrete, mortar, or grout by ramming into a confined space.

### Dry pressing

See Pressing, dry.

### Dry process

See Process, dry.

### Dry spots

Small areas on the face of tile which have been insufficiently glazed.

### Dry-set mortar

A water-retentive hydraulic cement mortar usable with or without sand. When this mortar is used, neither the tile nor walls have to be soaked during the installation process.

### Drying

Removal by evaporation, of uncombined water or other volatile substance from a ceramic raw material or product, usually expedited by low temperature heating. (ASTM C242)

### Dunting

The cracking that occurs in fired ceramic bodies due to thermally induced stresses. (ASTM C242)

### Dusting

The application of dry Portland cement to a wet floor or deck mortar surface. A pure coat is thus formed by suction of the dry cement.

**Dutchman**

A cut tile used as a filler in the run of a wall or floor area.

**E****Eagle beak**

A 6"x3/4" outside corner trim shape. (AC 106) Earthenware. A glazed or unglazed nonvitreous ceramic whiteware. (ASTM C242)

**Edge-mounted tile**

A type of mounted tile. Tile is assembled into units or sheets and is bonded at the edges or corners of the back of the tiles by an elastomeric or resinous material which becomes an integral part of the tile installation. Units or sheets must meet criteria of back-mounted sheets. See definition for Mounted tile.

**Edge-bonded tile**

See definition for PregROUTED tile.

**Edger**

A finishing tool used on the edges of fresh concrete to provide a rounded corner.

**Efflorescence**

The residue deposited on the surface of a material by the crystallization of soluble salts.

**Egg shelling**

The texture of a fired glaze similar in appearance to the surface of an eggshell. (ASTM C242)

**Electrical porcelain**

Vitrified white ware having an electrical insulating function. (ASTM C242)

**Electrolysis**

Production of chemical changes by the passage of current through an electrolyte.

**Elastomeric**

A natural material, for example, rubber, or a synthetic material. for example, polyvinyl, that has elastic properties.

**Embossed**

A decoration in relief or excised on the ware surface. (ASTM C242)

**Engobe**

A slip coating applied to a ceramic body for imparting color, opacity or other characteristics, and subsequently covered with a glaze. (ASTM C242)

**Entrained air**

Microscopic air bubbles intentionally incorporated into mortar or concrete during mixing, usually by use of a surface-active agent. (See also Air entrainment)

**Epoxy adhesive**

A two-part adhesive system employing epoxy resin and epoxy hardener used for bonding of ceramic tile to back-up materials.

**Epoxy grout**

A two-part grout system consisting of epoxy resin and epoxy hardener, especially formulated to have impervious qualities, stain, and chemical resistance used to fill joints between tile units.

**Epoxy mortar**

A two-part mortar system consisting of epoxy resin and epoxy hardener used to bond tile to back-up material where chemical resistance of high bond strength is a consideration.

**Epoxy resin**

An epoxy composition used as a chemical resistant setting adhesive or chemical-resistant grout.

**Equilibrium eutectic**

See Eutectic, equilibrium. Eutectic. See Eutectic, deformation; Eutectic, equilibrium.

**Eutectic, deformation**

The composition within a system of two or more components which, on heating under specific conditions, develops sufficient liquid to cause deformation at minimum temperature. (ASTM C242)

**Eutectic equilibrium (eutectic)**

The composition within any system of two or more crystalline phases which melts completely at minimum temperature, or temperature at which such a composition melts. (ASTM C242)

**Expansion joint**

A joint through tile, mortar, and reinforcing wire down to the substrate.

**Exposed-aggregate finish**

A decorative finish for concrete work achieved by removing, generally before the concrete has fully hardened, the outer skin of mortar and exposing the coarse aggregate.

**Extra duty tile**

See Special purpose tile.

**Extruded tile**

A tile or trim unit that is formed when plastic clay mixtures are forced through a pug mill opening (die) of suitable configuration, resulting in a continuous ribbon of formed clay. A wire cutter or similar cut-off device is then used to cut the ribbon into appropriate lengths and widths of tile.

**F****Face Mounted Tile**

See mounted tile.

**Facial defect**

That portion of the facial surface of the tile which is readily observed to be nonconforming and which will detract from the aesthetic appearance or serviceability of the installed tile.

**Faience mosaics**

Faience that are less than 6 in facial area, usually 8 to 9.5 mm-thick, and usually mounted to facilitate installation. (ASTM C242)

**Faience tile**

Glazed or unglazed tile, generally made by the plastic process, showing characteristic variations in the face, edges, and glaze that give a handcrafted, nonmechanical, decorative effect. (ASTM C242)

**Faience ware**

Formerly decorated earthenware with an opaque glaze, but currently designating a decorated earthenware having a transparent glaze (ASTM C242)

**Fan or fanning**

Spacing tile joints to widen certain areas so they will conform to a section that is not parallel.

**Fascia**

A flat member or band at the surface of a building or the edge beam of a bridge; exposed eaves of a building; often inappropriately called fascia.

**Feather edge**

A wood or metal tool having a beveled edge; used to straighten re-entrant angles in finish plaster coat; also edge of a concrete or mortar placement such as a patch or topping that is beveled at an acute angle.

**Featheredging file (mitering)**

The method of chipping away the body from beneath a facial edge of a tile in order to form a miter.

**Feature strip (decorated liner)**

A narrow strip of tile that has a contrasting color, texture, or design.

**Feldspar**

A mineral aggregate consisting chiefly of microcline, albite and/or anorthite. (ASTM C242)

**Fiberglass**

The name for products made of or with glass fibers ranging from 5 to 600 hundred-thousandths inch in diameter. Used for making textile fabrics and for heat or sound insulation.

**Field tile**

Tile other than trim tile covering a wall or floor.

**Filler**

See Spacing mix.

**Final setting time**

The time required for a freshly mixed cement paste, mortar or concrete to achieve final set.

**Fire**

See Fire, bisque; Fire, decorating; Fire, glost; Fire, single.

**Fire clay**

An earthy or stony mineral aggregate which has as the essential constituent hydrous silicates of aluminum with or without free silica, plastic when sufficiently pulverized and wetted, rigid when subsequently dried, and of suitable refractoriness for use in commercial refractory products.

**Fineness modulus**

A factor obtained by adding the total percentages by weight of an aggregate sample retained on each of a specified series of sieves, and dividing the sum by 100. In the United States the standard sieve sizes are No. 100 (150 µm), No. 30 (600 µm), No. 16 (1.18 mm), No. 8 (2.36 mm) and No. 4 (4.75 mm), and a/s in. (9.5 mm), 3/a in. (19 mm), 1 1/2 in. (38.1 mm), 3 in. (75 mm), and 6 in. (150 mm).

**Fire, bisque**

The process of kiln-firing ceramic ware prior to glazing. (ASTM C242)

**Fire, decorating**

The process of firing ceramic or metallic decorations on the surface of glazed ceramic ware. (ASTM C242)

**Fire, glost**

The process of kiln-firing bisque ware to which glaze has been applied. (ASTM C242)

**Fire, single**

The process of maturing an unfired ceramic body and its glaze in one firing operation. (ASTM C242)

**Firing**

The controlled heat treatment of ceramic ware in a kiln or furnace, during the process of manufacture, to develop the desired properties. (ASTM C242)

**Firing range**

The range of firing temperature within which a ceramic composition develops properties which render it commercially useful. (ASTM C242)

**Flaked**

Irregularities left on the edge of the tile mainly due to the use of machine cutting tools.

**Flammable**

Capable of being easily ignited.

**Flash point**

The temperature at which the material gives off flammable vapor in sufficient quantity to ignite momentarily on the application of a flame under specified conditions.

**Flat Back Troweling**

Formerly known as backbuttering. Using the flat side of the trowel (keying in or burning in) – of a thin layer of modified/non-modified dry-set mortar (thinset mortar) to the backside of the tile just before the tile is embedded into the still wet setting mortar.

**Flexural strength**

A property of a material or structural member that indicates its ability to resist failure in bending. (See also Modulus of rupture.)

**Float coat**

The final mortar coat over which the neat coat, pure coat, or skim coat is applied.

**Float strip**

A strip of wood about 6 mm-thick and 38 mm-wide. It is used as a guide to align mortar surfaces.

**Floating**

A method of using a straightedge to align mortar with the float strips or screeds. This technique also is called dragging, pulling, rodding, or rodding off.

**Fluorite (Ca F<sub>2</sub>) (fluorspar)**

An inorganic mineral of the isometric form, used as a source of fluorine for fluxing of glasses and glazes.

**Flux**

A substance that promotes fusion in a given ceramic mixture. (ASTM C242)

**Fog curing**

1. Storage of concrete in a moist room in which the desired high humidity is achieved by the atomization of fresh water. (See also Moist room).
2. Application of atomized fresh water to concrete, stucco, mortar, or plaster.

**Form oil**

Oil applied to interior surface of form work to promote easy release from the concrete when forms are removed.

**Forming**

The shaping or molding of ceramic ware. (ASTM C242)

**Forsterite porcelain**

A vitreous ceramic whiteware for technical application in which forsterite (2MgO SiO) is the essential crystalline phase. (ASTM C242)

**Forsterite whiteware**

Any ceramic whiteware in which Forsterite (2MgO - SiO) is the essential crystalline phase. (ASTM C242)

**Freehand floating**

The application of wall mortar without the use of guide screeds. This technique is used by specialists when they are setting glass mosaic murals.

**Frit**

A glass which contains fluxing material and is employed as a constituent in a glaze, body or other ceramic composition. (ASTM C242)

**Fritted glaze**

A glaze in which a part or all of the fluxing constituents are prefused. (ASTM C242)

**Frost proof tile**

Tile produced for use where freezing and thawing conditions occur. (CTI)

### **Furan mortar**

A two-part mortar system of furan resin and furan hardener used for bonding tile to back-up material where chemical resistance of floors is important.

### **Furan Plastics**

Plastics based on resins in which the furan ring is an integral part of the polymer chain, made by the polymerization -or polycondensation of furfural, furfuryl alcohol, or other compounds containing a furan ring, or by the reaction of these furan compounds with other compounds, the furan being in greater amount by weight.

### **Furan Grout**

An intimate mixture of a furan resin, selected fillers and an acid catalyst. Fillers are generally carbon, silica or a combination thereof into which the acid catalyst, or setting agent, may be incorporated. When combined, the components form a flowable chemical resistant material for grouting tile.

### **Furan resin**

A furan resin composition used as a chemical-resistant setting adhesive or chemical-resistant grout.

### **Furan resin grout**

A two-part grout system of furan resin and furan hardener used for filling joints between quarry tile and pavers where chemical resistant properties are required.

### **Furring**

Stripping used to build out a surface such as a studded wall where strips of suitable size are added to the studs to accommodate vent pipes or other fixtures.

### **Fusion**

The process of melting; usually the result of interaction of two or more materials. (ASTM C242)

## **G**

### **Gauged Porcelain Tile (GPT)**

Tiles that have been manufactured to a specific nominal thickness, and whose thickness characteristic is largely associated with how they are installed and/or used. See ANSI A136.3

### **Gauged Porcelain Tile Panel/Slab (GPTPS)**

See Gauged Porcelain Tile

### **Gilmore needle**

A device used in determining time of setting of hydraulic cement.

### **Glass Mesh Mortar Unit/Cementitious Backer Unit**

A backer board designed for use with ceramic tile in wet areas. It can be used in place of metal lath, Portland cement scratch coat and mortar bed.

### **Glass mosaic tiles**

Tiles made of glass, usually in sizes not over 2" square and 1/4"-thick, mounted on sheets of paper. Usually sheets are 12" square.

### **Glaze**

A ceramic coating matured to the glassy state on a formed ceramic article. The term glaze also refers to the material or mixture from which the coating is made. (ASTM C242). Bright glaze. A high-gloss coating with or without color. (ASTM C242). Clear glaze. A transparent glaze with or without color. (ASTM C242). Crystalline glaze. A glaze that contains microscopic crystals. (ASTM C242). Fritted glaze. A glaze in which a part or all of the fluxing constituents are prefused. (ASTM C242). Matt glaze. A low-gloss ceramic glaze with or without color. (ASTM C242). Opaque glaze. A nontransparent glaze with or without color. (ASTM C242). Raw glaze. A glaze compounded primarily from raw constituents. It contains no prefused materials. (ASTM C242). Semi matte glaze. A medium-gloss ceramic glaze with or without color. (ASTM C242). Speckled glaze. A glaze containing granules of oxides or ceramic stains that are of contrasting colors.

### **Glaze fit**

The stress relationship between the glaze and body of a fired ceramic product. (ASTM C242)

### **Glazed interior tile**

A glazed tile with a body that is suitable for interior use and which is usually nonvitreous, and is not required or expected to withstand excessive impact or be subject to freezing and thawing conditions. (ASTM C242)

### **Glazed paver tile**

See Pavers. Glazed quarry tile. See Quarry tile. Glazed tile. Tile with a fused impervious facial finish composed of ceramic materials, fused into the body of the tile which may be a nonvitreous, semi vitreous, vitreous, or impervious body. The glazed surface may be clear, white, or colored. (ASTM C242) Glazed tile, extra duty glaze. Tile with a durable glaze that is suitable for light duty floors and all other surfaces on interiors where there is no excessive abrasion or impact. (ASTM C242)

### **Glost fire**

See Fire, glost.

### **Grade**

A predetermined degree of slope for floors requiring drainage.

### **Grades**

Grades of tile recognized in ANSI standard specifications for ceramic tile.

### **Grout**

A rich or strong cementitious or chemically setting mix used for filling tile joints.

### **Grouting**

The process of filling the tile joints with grout.

### **Grout saw**

The grout saw is a saw-toothed carbide steel blade mounted on a wooden handle. It is used to remove old grout. It also is used in patching work. Care should be used as it can easily damage adjacent tiles. The carbide steel blade is brittle, and it will shatter if it is dropped or abused. On front of the saw blade is a spring steel tip, used for scraping grout out of corners where the saw blade cannot reach.

### **Grout scrubbing pad**

A no scratch nylon pad impregnated with abrasive used for cleaning grout off tile. Hairline cracking.

### **Grout, colored**

See Colored grout.

## **H**

### **Half and half**

See Spacing mix.

### **Hard screed**

A mortar screed that has become firm.

### **Hard Tile**

A term used in the tile trade to designate types of tile, such as ceramic, glass mosaic, marble tile, etc. over which the tile trade has jurisdiction. Hard tile as compared to resilient tile.

### **Hawk**

Hawks range in size from 254 mm to 356 mm square, but tile setters generally prefer the 280 mm square. Most hawks are made of aluminum with a wooden handle at the center. A rubber pad fits over the handle and covers that portion of the metal hawk that would come in contact with the hand. The hawk should not be held with a hand that is wet or covered with lime or mortar.

### **Healing power**

The ability of a glaze to heal surface blemishes during firing. (ASTM C242).

**Heavy duty tile**

Tile suitable for areas where heavy pedestrian traffic is prevalent. Tile can be specified to meet higher test values as determined by job requirements but a minimum heavy duty tile test requirement is necessary.

**Hod**

A portable trough for carrying mortar, bricks, etc., fixed crosswise on top of a pole and carried on the shoulder.

**Hollow casting**

See Casting, drain.

**Hopped-up mud**

Mortar mixed with an accelerator.

**Horizontal broken joints**

A style of laying tile with each course offset one-half its length.

**Horizontal Broken Joints**

A style of laying tile with each course offset one-half its length.

**Hot cement**

Newly manufactured cement which has not had an opportunity to cool after burning and grinding of the component materials.

**Hot-Mopped Pan**

A type of shower pan made of alternating layers of hot asphalt and tar paper.

**Hot mud or hot stuff**

Mortar mixed with an accelerator. Hot pressing.- See Pressing, hot, hopped-up mud.

**Hue**

The attribute by which a perceived color is distinguished as red, yellow, green, blue, purple or a combination of these. White, gray and black colors possess no hue. Lightness – The attribute by which a perceived color is judged to be equivalent to a member of the continuous series of grays ranging from black to white. Saturation – The attribute by which a perceived color is judged to depart from gray of equal lightness toward a pure hue.

**Hydrate**

A chemical combination of water with another compound or an element.

**Hydrated lime**

Calcium hydroxide, a dry powder obtained by treating quicklime with Hydraulic – (cement) (mortar) Those products that will set or harden under water.

**I****Impervious**

That degree of vitrification evidenced visually by complete resistance to dye penetration. (ASTM C242). NOTE: The term impervious generally signifies zero absorption, except for floor and wall tile which are considered impervious up to 0.5 percent water absorption.

**Impervious tile**

Water absorption of 0.5 percent or less.

**In/Out Corner**

Trim tile for turning a right-angle inside or outside wall corner.

**Incised**

Decorated by cutting or indenting the ware surface. (ASTM C242)

**Inglaze decoration**

See Decoration, inglaze.

**Initial setting time**

The time required for a freshly mixed cement paste, mortar, or concrete to achieve initial set. (See also Final setting time.)

**Ironstone ware**

(Also called Stone China or Granite Ware) Historic term for a durable English earthenware. (ASTM C242)

**ISO**

International Standards Organization

**Isolation joint**

A separation between adjoining parts of a concrete structure, usually a vertical plane, at a designed location such as to interfere least with performance of the structure, yet such as to allow relative movement and avoid formation of cracks elsewhere in the concrete. (See also Contraction joint.)

**J****Jagged edges**

Irregularities left on the edges of the tile due to the use mainly of hand cutting tools.

**Jasper ware**

A vitreous, opaque, colored unglazed ceramic ware having white or contrasting relief-decorations and containing a substantial amount of barite. Originally developed by Josiah Wedgwood. (ASTM C242)

**Jigging**

Forming ceramic ware from a plastic body by differential rotation of a profile tool and mold, the mold having the contour of one surface of the ware and the profile tool that of the other surface. (ASTM C242)

**Jitterbug**

A grate tamper for pushing coarse aggregate slightly below the surface of a slab to facilitate finishing.

**Joint filler**

Compressible material used to fill a joint to prevent the infiltration of debris and to provide support for sealants.

**Joint sealant**

Compressible material used to exclude water and solid foreign materials from joints.

**Joint, control**

See Expansion joint.

**Joint, contraction**

See Contraction joint.

**Joint, expansion**

See Expansion joint.

**Jointer (concrete)**

A metal tool about 150 mm long and from 50 to 100 mm wide and having shallow, medium, or deep bits (cutting edges) ranging from 5 to 20 mm or deeper used to cut a joint partly through fresh concrete.

**Journeyman**

An experienced reliable worker who has learned his trade and works for another person.

**K****Kaolin (china clay)**

A refractory clay consisting essentially of minerals of the kaolin group and which fires to a white or nearly white color. (ASTM C242)

**Keene's cement**

A cement composed of finely ground, anhydrous, calcined gypsum, the set of which is accelerated by the addition of other materials.

**Knockings**

The oversize residue obtained in screening a ceramic slip. (ASTM C242)

**Kyanite**

The most abundant of the mineral polymorphs that include andalusite and sillimanite. Kyanite is used as a source of mullite in ceramics. (ASTM C21)

**L****L cut**

A piece of tile cut or shaped to the letter L.

**Laitance**

A layer of weak and nondurable material containing cement and fines from aggregates, brought by bleeding water to the top of wet concrete; the amount of which is generally increased by overworking or over manipulating concrete at the surface by improper finishing or by job traffic.

**Lap**

The length by which one bar or sheet of fabric reinforcement overlaps another.

**Latex**

A water emulsion of a synthetic rubber or plastic obtained by polymerization and used especially in coatings and adhesives.

**Latex-Portland cement grout**

A Portland cement grout with a special latex additive which results in a less rigid, less permeable grout than regular Portland cement grout.

**Latex-Portland cement mortar**

A mixture of Portland cement, sand, and special latex additives which is used for bonding tile to back-up material. It is less rigid than Portland cement mortar.

**Lath**

A wood strip or metal mesh, which acts as a background or reinforcing agent for the scratch coat or mortar coat.

**Layout Lines**

Lines chalked on a substrate to guide in accurately setting tile.

**Layout stick**

A long strip of wood marked at the appropriate joint intervals for the tile to be used. It is used to check the length, width, or height of the tile work. A common name for this item is idiot stick.

**Leadless glaze**

A ceramic coating matured to a glassy state on a formed article, or the material or the mixture from which the coating is made, to which no lead has been deliberately added. (ASTM C21) NOTE: This does not imply that the glaze is nontoxic or that it contains no lead. Because of plant practices and conditions, a small percentage of lead, 0.1 to 0.2% (by dry weight), expressed as lead monoxide, may be present.

**Leg**

A tile wall running alongside a bathtub or abutment. This term sometimes is used to describe a narrow strip of tile wall.

**Level**

- a. A surface or line with all points at the same elevation
- b. Horizontally straight.

**Leveling coat**

See Plumb scratch.

**Light duty tile**

Tile suitable for limited pedestrian traffic such as entry ways in single family residences.

**Lime**

Specifically, calcium oxide (CaO); also, loosely, a general term for the various chemical and physical forms of quicklime, hydrated lime and hydraulic hydrated lime.

**Limestone**

A sedimentary carbonate rock, composed chiefly of calcite (Ca CO<sub>3</sub>), but sometimes containing appreciable dolomite. (ASTM C21)

**Lippage**

A condition where one edge of a tile is higher than an adjacent tile giving the finished surface an uneven appearance.

**Live load**

Any load that is not permanently applied to a structure.

**Load-bearing wall**

A wall designed and built to carry superimposed vertical and shear loads as opposed to no-load-bearing walls.

**Lugs**

See Self-spacing tile.

**M****Marble mosaic tile**

Tile made of small marble tesserae that varies slightly in size, usually about one half inch square and mounted on sheets of paper to facilitate installation. (CTI)

**Marble tiles**

Quarried marble, usually 3/4"-thick or less, various sizes, finishes available are polished, honed, split faced, acid washed etc.

**Master Grade certificate**

A certificate that states tile listed in the shipment and described on the certificate are made in accordance with TCNA 137.1-76.

**Mastic**

Tile adhesive.

**Mastic grout**

A chemical mixture of organic and inorganic ingredients forming a one part grouting composition that is used directly from the manufacturer's container.

**Mat glaze**

A colorless or colored ceramic glaze having low gloss. (ASTM C242)

**Maturing range**

The time-temperature range within which a ceramic body, glaze, or other composition may be fired to yield specified properties. (ASTM C242-72)

**Medium duty tile**

Tile suitable for pedestrian traffic such as entryways in multiple dwellings and lobbies.

**Melt**

To change a solid into a liquid by the application of heat; or the liquid resulting from such action. (ASTM C242)

**Metal quarry tile rack**

Metal quarry tile racks are available in many patterns, and they can be made to order for special patterns. They are used to maintain the same width between the quarry tiles.

**Mexican paver tile**

Terracotta-like tile, used mainly for floors, and handmade. This tile varies in color, texture and appearance, from tile to tile and within each tile. Available in squares up to 300 mm, hexagon, octagon, elongated hexagon, fleur de lis and other shapes. Tiles are coated with various types of sealers because of their soft absorptive characteristics. Coatings provide a wear surface for residential to light commercial use.

**MIA**

Marble Institute of America.

**MMSA**

Materials & Methods Standards Association.

**Mix**

The act or process of mixing; also mixture of materials, such as mortar or concrete.

**Mixer**

A machine used for blending the constituents of concrete, grout, mortar, cement paste, or other mixture.

**Mixer efficiency**

The adequacy of a mixer in rendering a homogeneous product within a stated period; homogeneity is determinable by testing for relative differences in physical properties of samples extracted from different portions of a freshly mixed batch.

**Mixer no tilting**

A horizontally rotating drum mixer that charges, mixes, and discharges without tilting.

**Mixer plant**

See Batch plant.

**Mixer, colloidal**

A mixer designed to produce colloidal grout.

**Mixer, horizontal shaft**

A mixer having a stationary cylindrical mixing compartment, with the axis of the cylinder horizontal, and one or more rotating horizontal shafts to which mixing blades or paddles are attached.

**Mixer, open-top**

A truck-mounted mixer consisting of a trough or a segment of a cylindrical mixing compartment with paddles or blades rotating about the horizontal axis of the trough. (See also Mixer, horizontal shaft.)

**Mixer, pan**

See Mixer, vertical shaft.

**Mixer, tilting**

A rotating drum mixer that discharges by tilting the drum about a fixed or movable horizontal axis at right angles to the drum axis. The drum axis may be horizontal or inclined while charging and mixing.

**Mixer, vertical shaft**

A cylindrical or annular mixing compartment having an essentially level floor and containing one or more vertical rotating shafts to which blades or paddles are attached; the mixing compartment may be stationary or rotate about a vertical axis.

**Mixing cycle**

The time taken for a complete cycle in a batch mixer, i.e., the time elapsing between successive repetitions of the same operation (e.g., successive discharges of the mixer).

**Mixing speed**

Rotation rate of a mixer drum or of the paddles in an open-top, pan, or trough mixer, when mixing a batch; expressed in revolutions per minute (rpm), or in peripheral feet per minute of a point on the circumference at maximum diameter.

**Mixing time**

The period during which the constituents of a batch of concrete are mixed by a mixer; for a stationary mixer, time is given in minutes from the completion of mixer charging until the beginning of discharge; for a truck mixer, time is given in good mixing in a specific mixing speed or expressed in terms of total revolutions at a specific mixing speed.

**Mixing water**

The water in freshly mixed sand-cement grout, mortar, or concrete, exclusive of any previously absorbed by the aggregate (e.g., water considered in the computation of the net water-cement ratio).

**Mixture**

The assembled, blended, co-mingled ingredients of mortar, concrete, or the like; or the proportions for their assembly.

**Modular ratio**

The ratio of modulus of elasticity of steel  $E_s$  to that of concrete  $E_c$ , usually denoted by the symbol  $N$ .

**Modulus of deformation**

A concept of modulus of elasticity expressed as a function of two time variables; strain in loaded concrete as a function of the age at which the load is initially applied and of the length of time the load is sustained.

**Modulus of rigidity**

The ratio of unit shearing stress to the corresponding unit shearing strain; referred to as "shear modulus" and "modulus of elasticity in shear"; denoted by the symbol  $G$ . (See also Modulus of elasticity.)

**Modulus of rupture**

A measure of the ultimate load carrying capacity of a beam and sometimes referred to as "rupture modulus" or "rupture strength". It is calculated for apparent tensile stress in the extreme fiber of a transverse test specimen under the load which produces rupture. (See also Flexural strength.)

**NOTE:** The actual stress in the extreme fiber is less than the apparent stress since the flexure formula employed in the calculation is valid only for stresses within the proportional limit of the material. Nevertheless, the nominal rupture strength so obtained is considered the rupture modulus.

**Modulus of sub grade reaction**

Ratio of load per unit area of horizontal surface (of a mass of soil) to corresponding settlement of the surface; it is determined as the slope of the secant, drawn between the point corresponding to zero settlement and a specified point on the load-settlement curve obtained from a plate load test on a soil using a 762 mm or greater diameter loading plate.

**Moist room**

A room in which the atmosphere is maintained at a selected temperature (usually  $23^{\circ}\text{C} \pm 1.7^{\circ}\text{C}$ ) and a relative humidity of at least 98 percent, for the purpose of curing and storing cementitious test specimen; the facilities must be sufficient to maintain free moisture continuously on the exterior of test specimens.

**Moisture expansion**

An increase in dimension or bulk volume of a ceramic article caused by reaction with water or water vapor. (ASTM C242) **NOTE:** This reaction may occur in time at atmospheric temperature and pressure, but is expedited by exposure of the article to water or water vapor at elevated temperatures and pressures.

**Moisture movement**

1. The movement of moisture through a porous medium;
2. The effects of such movement on efflorescence and volume change in hardened cement paste, mortar, concrete, or rock.

**Mold**

1. A divider containing a cavity into which neat cement, mortar, or concrete test specimens are cast;
2. A form used in the fabrication of precast mortar or concrete units (e.g., masonry units).

**Mold oil**

A mineral oil that is applied to the interior surface of a clean mold, before casting concrete or mortar therein, to facilitate removal of the mold after the concrete or mortar has hardened. (See also Form oil, Bond breaker, and Release agent).

**Moment distribution**

A method of structural analysis for continuous beams and rigid frames whereby successive converging corrections are made to an assumed set of moments until the desired precision is obtained; also known as the Hardy Cross method.

**Monochrome decoration**

A single color decoration. (ASTM C242)

**Monocottura (Single-Fired)**

Manufacturing process which allows the simultaneous firing of the clay with the glaze producing a finished tile. A single firing.

**Monolith**

A body of plain or reinforced concrete cast or erected as a single integral mass or structure.

**Monolithic concrete**

Concrete cast with no joints other than construction.

**Monolithic terrazzo**

The application of a 15 mm terrazzo topping directly to a specially prepared concrete substrata, eliminating an underbed.

**Monolithic topping**

On flatwork: a higher quality, more serviceable topping course placed promptly after the base course has lost all slump and bleeding water.

**Monomer**

An organic liquid, of relatively low molecular weight, that creates a solid polymer by reacting with itself or other compounds of low molecular weight.

**Monomolecular**

Composed of single molecules; specifically, films that are one molecule thick. Denotes a thickness equal to one molecule (e.g., certain chemical compounds develop a "monomolecular film" over bleeding water at the surface of freshly placed concrete or mortar as a means of reducing the rate of evaporation).

**Montmorillonite**

See Montmorillonoid.

**Montmorillonoid**

A group of clay minerals, including montmorillonite, characterized by a sheet-like internal molecular structure; consisting of extremely finely divided hydrous aluminum or magnesium silicates that swell on wetting, shrink on drying, and are subject to ion exchange.

**Mortar**

A mixture of cement paste and fine aggregate; in fresh concrete, the material occupying the interstices among particles of coarse aggregate; in masonry construction, mortar may contain masonry cement, or may contain hydraulic cement with lime (and possibly other admixtures) to afford greater plasticity and workability than are attainable with standard hydraulic cement mortar. (See also Cement, masonry and Masonry mortar).

**Mortar bed**

The layer of mortar on which tile is set. The final coat of mortar on a wall, floor or ceiling.

**Mortar hoe**

The mortar hoe is used for hand-mixing mortar. The best type has a perforated blade and a handle about 1676 mm in length. The hoe should be kept clean and free of all mortar so it can be pushed and pulled easily through a box of mortar.

**Mortar mixer**

An electric or gas driven machine designed to mix mortar.

**Mortar pumping machine**

The mortar pumping machine is used with the mortar mixer. Mixed mortar is poured into the hopper, and a pneumatic gun forces the mortar through a hose. The mortar can be delivered through the hose to tile setters working as high as 13 stories above the street. Admixtures are added to the mortar as a bonder so that the mortar in the hose will not separate. The plastering gun can be used on the hose, or the hose can be used as a hoist.

**Mortarboard**

The mortarboard is used as a table to hold mortar. It is usually 762 mm square.

**Mosaics**

Small tile or bits of tile, stone, or glass. These are used to form a surface design or an intricate pattern.

**Mounted tile**

Tile assembled into units or sheets by suitable material to facilitate handling and installation. Tile may be face-mounted, back-mounted or edge-mounted. Face-mounted tile assemblies may have paper or other suitable material applied to the face of each tile, usually by water soluble adhesives so that it can be easily removed after installation and prior to grouting of the joints. Back-mounted tile assemblies may have perforated paper, fiber mesh, resin or other suitable material bonded to the back and/or edges of each tile which becomes an integral part of the tile installation. Back-mounted and edge mounted tile assemblies shall have a sufficient exposure of tile and joints surrounding each tile to comply with bond strength requirements. Tile manufacturers must specify whether back-mounted and edge-mounted tile assemblies are suitable for installation in swimming pools, on exteriors and/or in wet areas.

**Mud**

A slang term for mortar.

**Murals**

Tile installed in a precise area of a wall or floor to provide a decorative design or picture. Glass or marble mosaic tile (tesserae) made to form a picture or design. Ceramic tile, painted and fired to form a picture or design. See Decorated and Decoration.

**Muriatic acid**

Hydrochloric acid (30% HCL), commercial grade.

**N****Natural clay tile**

A tile made by either the dust-pressed method or the plastic method, from clays that produce a dense body having a distinctive, slightly textured appearance. (ASTM C242).

**Neat cement grout**

Hydraulic cement in the non-hydrated state. Neat cement grout. A fluid mixture of hydraulic cement and water, with or without admixture; also the hardened equivalent of such mixture.

**Neat cement paste**

A mixture of hydraulic cement and water, both before and after setting and hardening.

**Neoprene**

A type of synthetic rubber with outstanding oil resistance. Can be used for quick-setting, high strength adhesives.

**NIOSH**

National Institute for Occupational Safety and Health

**Nominal sizes**

This is the approximate facial size or thickness of tile, expressed in inches or fractions of an inch, for general reference.

**Non-slip tile**

Tile having greater non-slip characteristics due to an abrasive admixture, abrasive particles in the surface, grooves or patterns in the surface or because of natural non-skid surface characteristics.

**Non-vitreous (non-vitrified) tile**

That degree of vitrification evidenced by relatively high water absorption. (ASTM C242)

**NOTE:** The term nonvitrificous generally signifies more than 10.0 percent water absorption, except for floor and wall tile which are considered nonvitreous when water absorption exceeds seven percent.

**Notched Back-Troweling**

After flat back-troweling has been completed, additional modified/non-modified dry-set mortar (thin-set mortar) is applied to the backside of tile and uniformly combed in one direction with an appropriate notched trowel just before the tile is embedded into the setting mortar

**NTCA**

National Tile Contractors Association

**NTMA**  
National Terrazzo and Mosaic Association

**O**

**Opaque glaze**  
A nontransparent colored or colorless glaze. (ASTM C242).

**Open time**  
The period of time during which the bond coat retains its ability to adhere to the tile and bond the tile to the substrate.

**Orange peel**  
A pitted texture of a fired glaze resembling the surface of rough orange peel. (ASTM C242)

**Organic adhesive**  
A prepared organic material, ready to use with no further addition of liquid or powders, for bonding tile to back-up material by the thinset method. Cures or sets by evaporation.

**Oven ware**  
Ceramic whiteware for culinary oven use. (ASTM C242).

**Overglaze decoration**  
See Decoration, overglaze.

**P**

**P.S.I. or psi**  
Pounds per square inch, a unit measure of pressure.

**Packing house tile**  
Similar to quarry tile but usually of greater thickness.

**Paper and wire**  
Felt paper and wire mesh (or metal lath) that are used as a backing; for the installation of tile. Paper mounted ceramic mosaics Ceramic mosaic tiles mounted on paper. Paper is applied to face of tile in sheets approximately twelve inches wide, twenty-four inches long.

**Pate dure (hard paste)**  
A French term designating ceramic whitewares fired at relatively high temperatures. (ASTM C242)

**Pate tendre (soft paste)**  
A French term designating ceramic whitewares fired at relatively low temperatures. (ASTM C242)

**Pavers**  
Unglazed porcelain or natural clay tile formed by the dust-pressed method and similar to ceramic mosaics in composition and physical properties but relatively thicker with 6 in. or more of facial area. (ASTM C242)

**Peeling**  
See Orange peel; Shivering.

**Pencil rod**  
Reinforcing steel rod with a diameter of 6 mm.

**pH**  
A simplified system of measuring acidity or alkalinity irrespective of the acid or alkali involved; in which neutrality is 7.0, e.g., Mineral Acid Solution is 1.0-2.8, Acetic Acid Solution or Citric Acid Solution is 3.0-4.0, Ammonia is 9.0, Lime Water is 12.0.  
Physical properties of ceramic tile. Those properties as measured by ASTM tests.

**Pinholes**  
Imperfections in the surface of a ceramic body or glaze resembling pin pricks. (ASTM C242)

**Pitted**  
Indentations in the finished surface of individual tiles other than at the corners and edges. These are caused by sharp corners on trowels and other tools of the workmen and are different than manufacturing defects.

**Pitting**  
Development of relatively small cavities in a surface, due to phenomena such as corrosion or cavitation, or, in concrete, localized disintegration. (See also Pop out.)

**Plaster**  
A cementitious material or combination of cementitious material and aggregate that, when mixed with a suitable amount of water, forms a plastic mass or paste which when applied to a surface, adheres to it and subsequently hardens, preserving in a rigid state the form or texture imposed during the period of plasticity; also the placed and hardened mixture. (See also Stucco.)

**Plastic cracking**  
Cracking that occurs in the surface of fresh concrete soon after it is placed and while it is still plastic.

**Plastic flow**  
See Creep.

**Plastic pressing**  
See Pressing, wet.

**Plasticity**  
A complex property of a material involving a combination of qualities of mobility and magnitude of yield value; that property of freshly mixed cement paste concrete, or mortar which determines its resistance deformation or ease of molding.

**Plasticizer**  
A material that increases plasticity of a cement paste, mortar, or concrete mixture.

**PLI**  
Pounds per lineal inch.

**Plumb**  
Perpendicular to a true level.

**Plumb scratch**  
An additional scratch coat that has been applied to obtain a uniform setting bed on a plumb vertical plane.

**Pointing mix**  
Mortar with a consistency of stiff paste. The mix is forcibly compressed into the tile joints where it hardens.

**Poisson's ratio**  
The ratio of transverse (lateral) strain to the corresponding axial (longitudinal) strain resulting from uniformly distributed axial stress below the proportional limit of the material; the value will average about 0.2 for concrete and 0.25 for most metals.

**Polychrome decoration**  
A multicolor decoration. (ASTM C242)

**Polyethylene**  
A thermoplastic high-molecular-weight organic compound used in formulating protective coatings or, in sheet form, as a protective cover for concrete surfaces during the curing period, or to provide a temporary enclosure for construction operations.

**Pop out**  
The breaking away of small portions of a concrete surface due to internal pressure which leaves a shallow, typically conical, depression.

**Porcelain**  
A glazed or unglazed vitreous ceramic white ware used for technical purposes. This term designates such products as electrical, chemical, mechanical, structural, and thermal wares when they are vitreous. (See also, Alumina porcelain; Cordierite porcelain; Forsterite porcelain; Steatite porcelain; Titania porcelain; and Zircon porcelain.) (ASTM C242)

**Porcelain process**

The method of producing glazed ware by which a ceramic body and glaze are matured together in the same firing operation. (ASTM C242)

**Porcelain tile**

A ceramic mosaic tile or paver that is generally made by the dust-pressed method, of a composition resulting in a tile that is dense, fine-grained, and smooth with sharply formed face, usually impervious. (ASTM C242)

**Porosity, apparent**

The relationship of the open pore space to the bulk volume, expressed in percent. (ASTM C242)

**Post-tensioning**

A method of pre-stressing reinforced concrete in which tendons are tensioned after the concrete has hardened.

**Pot life**

The period of time during which a material maintains its workable properties after it has been mixed.

**Pottery**

All fired ceramic wares that contain clay when formed, except technical, structural and refractory products. (ASTM C242)

**Precast**

A concrete member that is cast and cured in other than its final position; the process of placing and finishing precast concrete.

**Precast concrete**

Concrete cast elsewhere than its final position.

**Preload**

The term used to describe mortar that has been placed and allowed to harden prior to bonding tile to it with thin-set materials.

**Pregouted tile**

A surface unit consisting of an assembly of ceramic tile bonded together at their edges by a material, generally elastomeric, which seals the joints completely. Such material (grout) may fill the joint completely, or partially and may cover all, a portion or none of the back surfaces of the tiles in the sheets. The perimeter of these factory pregouted sheets may include the entire, or part of the joint between the sheets or none at all. The term edge bonded tile is sometimes used to designate a particular type of pregouted tile sheets having the front and back surfaces completely exposed.

**Pressing**

See Pressing, dry; Pressing, hot; Pressing, wet.

**Pressing, dry**

Forming ceramic ware in dies from powdered or granular material by direct pressure. (ASTM C242)

**Pressing, hot**

A jiggering process wherein a heated profile tool or plunger is employed. (ASTM C242-72)

**Pressing, wet (plastic pressing)**

Forming ceramic ware in dies from a plastic body by direct pressure. (ASTM C242)

**Prestressed concrete**

Concrete in which internal stresses of such magnitude and distribution are introduced that the tensile stresses resulting from the service loads are counteracted to a desired degree; reinforced concrete the prestress is commonly introduced by tensioning the tendons.

**Pretensioning**

A method of pre-stressing reinforced concrete in which the tendons are tensioned before the concrete has hardened.

**Primary clay (residual clay)**

A clay which remains geologically at its site of formation. (ASTM C242).

**Process, dry (dry mix)**

The method of preparation of a ceramic body wherein the constituents are blended dry, following which liquid may be added as required for subsequent processing. (ASTM C242)

**Process, wet (slip process)**

The method of preparation of a ceramic body wherein the constituents are blended in sufficient liquid to produce a fluid suspension for use as such or for subsequent processing. (ASTM C242)

**Pumice**

A highly porous and vesicular lava usually of relatively high silica content composed largely of glass drawn into approximately parallel or loosely entwined fibers, which themselves contain sealed vesicles.

**Pumped concrete**

Concrete which is transported through hose or pipe by means of a pump.

**Pure**

See Neat cement.

**Pure coat**

A thin coat of pure Portland cement which is used to bond tile to mortar.

**Pyrophyllite**

A hydrated aluminum silicate mineral of the theoretical composition  $A12O3 \cdot 4SiO2 \cdot H2O$ , having physical properties in the raw state resembling mineral talc. (ASTM C21)

**Q****Quality assurance**

A system of procedures for selecting project or portion thereof to perform the functions intended, and assuring that these levels are obtained.

**Quality control**

A system of procedures and standards by which a constructor, product manufacturer, materials processor, or the like, monitors the properties of the finished work.

**Quarry tile**

Unglazed tile, usually 150 mm or more in surface area and 13 to 19 mm in thickness, made by the extrusion process from natural clay or shales. (ASTM C242)

**Quartering**

A method of obtaining a representative sample by dividing a circular pile of a larger sample into four equal parts and discarding opposite quarters successively until the desired size of sample is obtained.

**Quicklime**

Calcium oxide (CaO). (See also Lime.)

**R****Rack**

A metal grid that is used to properly space and align floor tiles.

**Ragging Off**

The procedure of spreading a damp cloth and pulling it over the tile surface during the tile grouting process in order to clean the tile.

**Rake or rake line**

The inclination from a horizontal direction.

**Raked joint**

A joint in a masonry wall which has the mortar raked out to a specified depth while it is only slightly hardened.

**Raw glaze**

A glaze compounded primarily from raw constituents, that is, containing no prefused materials. (ASTM C242)

**Receptor**

A metallic or nonmetallic waterproof support for a shower stall.

**Reducer**

A trim unit used to reduce the radius of a bullnose or a cove to another radius or to a square.

**Reference lines**

A pair of lines chalked on a substrate that intersect at a 90 degree angle and establish the starting point for plotting a grid of layout lines to guide in accurately setting tile.

**Refractory concrete**

Concrete having refractory properties, and suitable for use at high temperatures (generally about 315° to 1315°C), in which the binding agent is hydraulic cement.

**Reinforced concrete**

Concrete containing adequate reinforcement (prestressed or not prestressed) and designed on the assumption that the two materials act together in resisting forces.

**Reinforced masonry**

Unit masonry in which reinforcement is embedded in such a manner that the two materials act together in resisting forces.

**Reinforcement, mesh**

See Welded-wire fabric and Welded-wire fabric reinforcement.

**Relative humidity**

The ratio of the quantity of water vapor actually present to amount present in a saturated atmosphere at a given temperature; expressed as a percentage.

**Release agent**

Material used to prevent bonding of concrete to a surface. (See also Bond breaker.)

**Return**

The ending of a small splash wall or a wainscot at right angle to the major wall.

**Rockingham ware**

A semi-vitreous ware or earthenware having a brown or mottled brown bright glaze. Originated in England on the estate of the Marquis of Rockingham. (ASTM C242)

**Rod saw**

The rod saw is one of the newest tools used in the cutting of tile. It is a steel rod approximately 1/8" in diameter. The rod has tungsten carbide particles embedded in the surface. The rod saw is used to cut circles or irregular curves in tile.

**Rodding**

See Floating.

**Roughing in**

The act of preparing a surface by applying tar paper and metal lath (or wire mesh). Sometimes called wiring.

**Rubber trowel**

The rubber trowel used for grouting is a non-porous synthetic-rubber-faced float that is mounted on an aluminum back with a wood handle. This trowel is used to force material deep into tile joints and to remove excess material for a perfect finish.

**Rubbing stone**

A carborundum stone that is used to smooth the rough edges of tile.

**Running bond**

Stretchers overlapping one another by one-half unit, with vertical joint in alternate courses.

**S****Sag**

A term used when a wall surface has developed a slide.

**Salamander**

A portable source of heat, customarily oil burning, used to heat an enclosure around or over newly placed concrete to prevent the concrete from freezing.

**Saltillo Tile**

Adobe-type tile made of clay and other natural raw materials, molded and allowed to dry. Not a fired clay product.

**Sampling**

The method of obtaining tile for testing from an agreed-upon lot.

**Sand holes**

Tiny pits in the surface of the tile.

**Sandblast**

A system of cutting or abrading a surface such as concrete by a stream of sand ejected from a nozzle at high speed by compressed air; often used for cleanup of horizontal construction joints or for exposure of aggregate in architectural concrete.

**Sandblasting**

A method of scarifying the surface of concrete or masonry to provide a bondable surface. Compressed air is used to propel a stream of wet or dry sand onto the surface.

**Sander-grinder (Cutting tool)**

In addition to sander and grinder attachment both uninstalled and installed tile. The cutting is done dry.

**Sand-Portland Cement Grout**

An on-the-job mixture of Portland cement, fine graded sand, lime and water.

**Saturated Surface Dry (SSD)**

The condition when the pore space between the aggregate in the concrete full of water but no water is present on the surface.

**Saw cut**

A cut in hardened concrete utilizing diamond or silicone-carbide blades or discs.

**Sawed joint**

A joint cut in hardened concrete, generally not to the full depth of the member, by means of special equipment.

**Scaffolding**

A temporary structure for the support of deck forms, cart ways, or workmen, or a combination of these such as an elevated platform for supporting workmen, tools, and materials; adjustable metal scaffolding is frequently adapted for shoring in concrete work.

**Scarify**

Mechanical means of roughening a surface to obtain a better bond.

**Scarred faces**

Surface blemishes caused by scraping or other marring of the tile.

**Scratch**

A mixture of Portland cement, sand, and water.

**Scratch coat**

The first coat of plaster or stucco applied to a surface in three-coat work; usually cross-raked or scratched to form a mechanical key with the brown coat.

**Scratched**

Tiles that have surface scratches (usually glazed wall tile) caused from sand, tools or rough handling.

**Scratcher**

Any serrated or sharply tined object that is used to roughen the surface of one coat of mortar to provide a mechanical key for the next coat.

**Scratches**

Any serrated or sharply tined object that is used to roughen the surface of one coat of mortar to provide a mechanical key for the next coat. See also Scarify.

**Scratching**

The application of a scratch coat and its combing with a scratches.

**Screed**

To strike off mortar laying above the desired plane or shape.

**Screed guide**

Firmly established grade strips or side forms for unformed concrete which will guide the strike off in producing the desired plane or shape.

**Screed or Screed Strip**

Strips of wood, metal, mortar or other material used as guides on which a straightedge is worked to obtain a true mortar surface.

**Sculptured tile**

Tile with a decorative design of high and low areas molded into the finished fare.

**Sealant**

An elastomeric material that is used to fill and seal the expansion joint. This material prevents the passage of moisture and allows horizontal and lateral movement at the expansion joint.

**Sealing compound**

See joint sealant.

**Second grade ceramic tile**

Ceramic tile with appearance defects not affecting wearing or sanitary qualities.

**Self-furring**

Metal lath or welded wire fabric formed in the manufacturing process to include means by which the material is held away from the supporting surface, thus creating a space for "keying" of the insulating concrete, plaster, or stucco.

**Self-spacing tile**

Tile with lugs, spacers, or protuberances on the sides. These devices automatically space the tile for the grout joints. (SS-T-308b)

**Semi-mat glaze**

Having moderate gloss. (ASTM C242)

**Semi-porcelain**

A trade term designating semi-vitreous dinnerware. (ASTM C242)

**Semi-vitreous**

Less than 3 percent to 7 percent water absorption.

**Set**

The condition reached by a cement paste, mortar, or concrete when it has lost plasticity to an arbitrary degree, usually measured in terms of resistance to penetration or deformation; initial set refers to first stiffening; final set refers to attainment of significant rigidity; also, strain remaining after removal of stress.

**Setting Bed**

The layer of mortar on which the tile is set. The final coat of mortar on a wall or ceiling may also be called a setting bed.

**Setting time**

See Set.

**Shade**

The gradation of color.

**Sharp sand**

Coarse sand of which the particles are of angular shape.

**Shear**

A force that tends to slide or rupture one part of a body from another part of the body or from attached objects.

**Shear test**

A method of separating two materials by forcing (either by compression or tension) the interfaces to slide over the other. The force exerted is distributed over the entire bonded area at the same time. Strengths are recorded in psi.

**Shear wall**

A wall portion of a structural frame intended to resist lateral forces, such as earthquake, wind, and blast, acting in or parallel to the plane of the wall.

**Shelf Life**

The maximum period of time that an item can be stored before it is used.

**Ship and galley tile**

A special quarry tile having an indented pattern on the face of the tile to produce an anti-slip effect. (ASTM C242)

**Shivering (peeling)**

The splintering which occurs in fired glazes or other ceramic coatings due to critical compressive stress. (ASTM C242)

**Shore A hardness**

The reading of a material's hardness on a durometer, the scale of which is 0-100, used on elastomers as polyacrylic esters and natural rubber. Consists of a pinpoint depression into the material, the material being at least 100 mils thick. A Shore A reading of 80 equals a Shore D reading of 30.

**Shore D hardness**

The reading of a material's hardness on a durometer similar to the Shore A durometer, the scale of which is 0-100, used on rigid and semi-rigid materials such as polystyrene. Consists of a pinpoint depression into the material. Both the Shore A and Shore D instruments are made by the Shore Instrument Manufacturing Company, Inc., Jamaica, New York.

**Shower pan**

Terminology in some areas for Waterproof membrane. (CTI)

**Shower receptor**

The floor and side walls of the shower tip to and including the curb of the shower. (CTI) Shower receptor liner or lining. Terminology used in some areas for Waterproof membrane.

**Shrinkage**

The decrease in volume, or contraction, of a material by the escape of any volatile substance, or by a chemical or physical change in the material. Shrinkage crack. Crack due to restraint of shrinkage.

**Shrinkage cracking**

Cracking of a structure or member due to failure in tension caused by external or internal restraints as reduction in moisture content develops, or as carbonation occurs, or both.

**Silica (SiO<sub>2</sub>)**

The common oxide of silicon usually found naturally as quartz or in complex combination with other elements as silicates. Various polymorphs and natural occurrences of silica include cristobalite, tridymite, cryptocrystalline chert, flint, chalcedony, and hydrated opal.

**Silicone Grout**

An engineered elastomeric grout system for interior use.

**Sink Angle**

Trim shape used on a drain board at the corners of the kitchen sink. This trim shape, which is AU 106, is also called a "Butterfly"

**Skid resistance**

A measure of the frictional characteristics of a surface.

**Skim coat**

See Bond coat.

**Slake**

Allowing the mixtures of mortar, thinset mortar or grout to stand for a brief period of time after the ingredients have been thoroughly combined and before the final mixing occurs. Slaking enables the moisture in the mix to penetrate lumps in the dry components, making it easier to complete the mixing procedure.

**Slide**

A fresh tile wall that has buckled or sagged. This condition may be caused by excessive mortar, insufficient lime in the mortar, or excessive moisture in the scratch coat. A slide also may result if the surface is slick or the mortar is too soft.

**Slip (slurry)**

A suspension of ceramic material in liquid. (ASTM C242)

**Slip coating**

A ceramic material or mixture other than a glaze, applied to a ceramic body and fired to the maturity required to develop specified characteristics. (ASTM C242)

**Slip glaze**

A glaze consisting primarily of a readily fusible clay or silt. (ASTM C242)

**Slip process**

See Process, wet.

**Slip-resistant tile**

Tile having greater slip-resistant characteristics due to an abrasive admixture, abrasive particles in the surface or grooves or patterns in the surface.

**Slot cut**

Description of a tile that has been cut to fit around pipes or switch boxes. This tile is usually in the shape of the letter u or the letter L.

**Slump**

A measure of consistency of freshly mixed concrete, mortar, or stucco equal to the subsidence measured.

**Slump cone**

A mold in the form of the lateral surface of the frustum of a cone with a base diameter of 203 mm, top diameter 102 mm, and height 305 mm, used to fabricate a specimen of freshly mixed concrete for the slump test; a cone 152 mm high is used for tests of freshly mixed mortar and stucco.

**Slump test**

The procedure for measuring slump.

**Slurry**

A mixture of water and any finely divided insoluble material, such as Portland cement, slag, or clay in suspension.

**Slush coat**

A pure coat of very soft consistency. This also is called a slurry coat.

**Smelt**

A specific batch or lot of frit. The act of melting a batch of frit. (ASTM C21).

**Smelter**

A furnace in which the raw materials of a frit batches are melted. (ASTM C21)

**Soaping tile**

The method of applying a soapy film to newly tiled walls to protect them from paint and plaster during construction.

**Soffit**

The underside of a part or member of a structure, such as a beam, stairway, or arch.

**Soil**

A generic term for unconsolidated natural surface material above bedrock.

**Soldier course**

Oblong tile laid with the long side vertical and all joints in alignment.

**Solid casting**

See Casting, solid.

**Solids**

The dry ingredients remaining after evaporation of all volatile solvent or water. Not a fluid and not flowable.

**Soluble (adj.)**

Describes the property of a substance to dissolve in another and form a solution, e.g., sugar is soluble in water.

**Solution**

The process by which a substance (solid, liquid, or gas) is homogeneously mixed with a liquid, called the solvent, and the mixture being incapable of mechanical separation into its components. Alloys and amalgams are solutions of metals in metal; brines are solutions of a salt in water; syrups are solutions of sugars in water. Solution should not be confused or used interchangeably with such terms as dispersion, suspension or emulsion.

**Solvent**

In a solution, that substance which dissolves another is called the solvent. Solvent is also a common term for many liquids which are commonly used in making solutions, e.g., organic solvents, petroleum solvents, etc. Also used for thinning down a fluid, and for cleaning purposes.

**Spacers**

T-shaped, Y-shaped and cross shaped, they are used in installations to separate tile on walls and floors. They are manufactured in thicknesses of 1.5 mm, 3 mm, 6 mm, 10 mm, and 13 mm.

**Spacing; mix**

A dry or dampened mixture of one part Portland cement and one part extra-fine sand. This mix is used as a filler in the joints of mounted ceramic mosaic tiles to keep them evenly spaced during installation.

**Spall**

A fragment, usually in the shape of a flake, detached from a larger mass by a blow, by the action of weather, by pressure, or by expansion within the larger mass.

**Spandrel**

That part of a wall between the head of a window and the sill of the window above it.

**Special-purpose tile**

A tile, either glazed or unglazed, made to meet or to have specific physical design or appearance characteristics such as size, thickness, shape, color, or decoration; keys or lugs on backs or sides, special resistance to staining, frost, alkalis, acids, thermal shock, physical impact, high coefficient of friction, or electrical properties. (ASTM C242)

**Specific gravity**

The ratio of the weight of any volume of a mass or substance to the weight of an equal volume of water at a given temperature. The specific gravity of a substance times the density of water equals the density of the substance.

**Specks**

Any dark dots on the tile less than .4 mm in diameter, and noticeable at a distance of more than three feet.

**Spit out**

A glaze defect of the pinhole type developed in the decorating kiln, due to evolution of minute gas bubbles from body or glaze. (ASTM C242)

**Splash walls**

The walls of a tile drain board or bathtub.

**Split L Cut**

An improper "L" cut that is made by splitting a tile instead of cutting it.

**Spodumene (alpha spodumene)**

A lithium mineral of the theoretical composition  $\text{Li}_2\text{O} - \text{Al}_2\text{O}_3 - 4\text{SiO}_2$  (monoclinic crystallization) which on heating inverts to beta spodumene, a form having very low nil thermal expansion. (ASTM C21)

**Spots**

Any dark dots on the face of the tile more than .4 mm in diameter.

**Spread**

The quantity of adhesive per unit area applied to an adherent, usually expressed in pounds of adhesive per thousand square feet of area.

1. Single Spread refers to application of adhesive to only one adherent.
2. Double Spread refers to application of adhesive to both adherents.

**Stability**

The ability to remain unchanged; equilibrium, steady, constant. Ability to restore to original condition after being disturbed by some force.

**Stacking tile**

A method of installation whereby glazed tiles are placed on the wall so that they are in direct contact with the adjacent tiles. The width of the joints is not maintained by the use of string or other means. The tiles may be set with either straight or broken joints.

**Staining**

Discoloration caused by a foreign matter chemically affecting the material itself.

**Standard grade ceramic tile**

Highest grade of all types of ceramic tile.

**Steam curing**

Curing of concrete or mortar in water vapor at atmospheric or higher pressures and at temperatures between about 40° and 215°C. (See also Autoclave curing).

**Steatite porcelain**

A vitreous ceramic whiteware for technical application in which magnesium metasilicate ( $\text{MgO} - \text{SiO}_2$ ) is the essential crystalline phase. (ASTM C 242)

**Steatite talc**

Massive talc or the pulverized product. thereof having the general formula  $3\text{MgO} - 4\text{SiO}_2, \text{H}_2\text{O}$ . (ASTM C242)

**Steatite whiteware**

Any ceramic whiteware in which magnesium metasilicate ( $\text{MgO} - \text{SiO}_2$ ) is the essential crystalline phase. (ASTM C242)

**Steel square**

The steel square is one of the most important tile setting tools. The large arm of the square is 51 mm-wide and 600 mm-long and is called the body or blade. The smaller arm is at a 90-degree angle to the blade and is 38 mm-wide and 406 mm-long; it is called the tongue. The point where the outside edges of the blade and tongue join is called the heel. The surface with the manufacturer's name is called the face; the opposite surface is called the back.

**Stoneware**

A vitreous or semi vitreous-ceramic ware of fine texture, made primarily from nonrefractory fire clay. (ASTM C 242)

**Stoning**

Use of a carborundum stone to smooth rough edges caused by cutting.

**Storage life**

The period of time during which a materials can be stored under specified temperature conditions and remain suitable for use. Sometimes called "shelf life".

**Story pole**

See Layout stick.

**Straight joint**

The usual style of laying tile where all the joints are in alignment.

**Straightedge**

A straight piece of lumber that is used to rod mortar and to align tile.

**Stretcher**

A masonry unit laid with its length horizontal and parallel with the face of a wall or other masonry member.

**Striking joints**

A process of removing excess grout from the joints by wiping with a sponge or cloth or scraping with a curved instrument.

**Structural defects**

Cracks or laminations in the body of the tile which detract from the aesthetic appearances and/or the structural soundness of the tile installation.

**Stucco**

A cement plaster used for coating exterior walls and other exterior surfaces of buildings. (See also Plaster.)

**Stud**

Vertical member of appropriate size 50x100 to 100x250 mm and spacing 400 to 750 mm to support sheathing; also a headed steel device used to anchor steel plates or shapes to concrete members.

**Sub floor**

A rough floor – plywood or boards – laid over joists and on which an underlayment or substrate is installed.

**Substrate**

The underlying support for the ceramic tile installation.

**T****Taber Abrader**

An instrument used to test the abrasion resistance of a material.

**Take-off man**

Someone who can read blueprints and is familiar with the specifications. This person makes tracings of special details concerning the tile work after gathering the necessary information and then estimates the labor, materials, tile quantities, and special trim shapes needed to complete the job.

**Tapping tile**

An inspection technique whereby a coin, key, or other small metallic object is tapped against an installed tile to determine by sound whether the tile is completely bonded to its backing. Tile setters often tap the tile with a pointing trowel to determine that a good bond has been achieved.

**TCNA**

Tile Council of North America

**Tensile strength**

The pulling force necessary to break a given specimen divided by the cross sectional area. Units given in lbs./ins. (P.S.I.). It measures the resistance of a material to stretching without rupture. Normally is not used with reference to elastic materials which recover after elongation.

**Terra cotta**

Hard baked clayware, including tile, of variable color, averaging reddish red-yellow in hue and of high saturation. (CTI)

**Terra sigillata**

A porous, red clay ware characterized by embossed decorations of the same color and a satin-like unglazed surface. Originated on the Island of Samos. (ASTM C242)

**Terrazzo concrete**

See Concrete, terrazzo.

**Terrazzo tile**

A terrazzo surface, on a Portland cement and sand body, made by a mixture of marble chips and Portland cement and usually ground smooth. (CTI)

**Tessara, tessarae**

A small chip of glass or marble used in mosaic formations. (CTI)

**Test**

A trial, examination, observation, or evaluation used as a means of measuring a physical or chemical characteristic of a material, or a physical characteristic of a structural element or a structure.

**Testing machine**

A device for applying test conditions and accurately measuring results.

**Testing of ceramic tile**

The act of determining whether ceramic tile is acceptable. See Physical properties of ceramic tile.

**Thermal conductivity**

Ability of a material to conduct heat; physical constant for quantity of heat that passes through unit volume of a substance in unit of time when difference in temperature of two opposite faces is one degree.

**Thick-bed mortar**

A thick layer of mortar (more than 13 mm) that is used for leveling.

**Thin-set**

A term used to describe the bonding of tile with suitable materials applied approximately 3 mm thick. See also Dry-Set mortar.

**3-4-5 Triangle**

A triangle with sides in the proportion of 3:4:5, which produces one 90 degree corner. Plotting a 3-4-5 triangle is a method used to establish a pair of square reference lines on a large surface. These lines can be used to determine if the installation site is square and to create a grid of layout lines for setting tile.

**Threshold, marble**

A piece of marble placed beneath a door.

**Tie wire**

The 18-gauge galvanized wire used in construction work.

**Tile**

A ceramic surfacing unit, usually relatively thin in relation to facial area, made from clay or a mixture of clay and other ceramic materials, called the body of the tile, having either a glazed or unglazed face and fired above red heat in the course of manufacture to a temperature sufficiently high to produce specific physical properties and characteristics. (ASTM C242)

**Tile assemblies**

See definition for Mounted tile.

**Tile cutter**

The cutter is one of the most efficient and economical tools in the tile setting trade. A popular model is the hand-drawn tile cutting board that is adjustable.

**Tile, mounted**

Tile assembled into units or sheets and bonded together to facilitate handling.

**Tile, back-mounted**

Mounted tile with perforated paper, fiber mesh, or other suitable bonding material applied to the backs or edges of the tile so that a relatively large proportion of tile area is exposed to the setting bed.

**Tile, face-mounted**

Mounted tile with paper applied to the faces of the tile. The water-soluble adhesive can be removed easily prior to grouting of the joints.

**Tile Nipper**

Special pliers that nibble away little bites of ceramic tile to create small, irregular or curved cuts.

**Tin Oxide (Sri OQ)**

In finely ground form used in glazes as an opacifier.

**Titania porcelain**

A vitreous ceramic whiteware for technical application in which titania (TiO<sub>2</sub>) is the essential crystalline phase. (ASTM C242)

**Titania whiteware**

Any ceramic whiteware in which titania (TiO<sub>2</sub>) is the essential crystalline phase. (ASTM C242)

**Tongue and groove**

A type of lumber or precast concrete tile having mated projecting and grooved edges to provide a tight fit, abbreviated "T & G."

**Trammel bar**

A trammel bar, which is easy to construct, is more accurate than many other layout tools. It is used to erect perpendicular lines and to bisect angles. The tile setter can make a trammel bar from a stick of a size that is suitable for the particular job.

**Trial batch**

A batch of concrete prepared to establish or check proportions of the constituents.

**Trimmers**

Units of various shapes consisting of such items as bases, caps, corners, moldings, angles, etc. necessary or desirable to make a complete installation and to achieve sanitary purposes as well as architectural design for all types of tile work. (ASTM C242)

**Trowels****Buttering trowel**

The blade of the buttering trowel is 114 mm-wide and 180 mm-long. It is used in buttering pure cement to tile, a method commonly used in the eastern states. The trowel is more efficient than the pointer for working on the larger and heavier tiles because more weight can be placed on it.

**Flat trowel**

The flat trowel is used in conjunction with the hawk for the transferring of mortar from the mortarboard to the wall or to other vertical surfaces. It is frequently used for spreading pure cement finished float coat. The flat trowel also is used for spreading mortar on floor surfaces before tiles are set.

**Gauging trowel**

The gauging trowel is larger than the pointing trowel but smaller than the buttering trowel. Tile setters prefer the 82 mm x 180 mm size.

**Notched trowels**

Notched trowels are available in the serrated, square tooth, and round designs. The teeth are made in various sizes. The correct tooth size and depth must be used to apply the thickness of bonding mortar specified. These trowels are used to apply all of the various kinds of bonding materials for ceramic tile. When the teeth become worn, the trowel has to be sharpened or replaced.

**U****Underglaze decoration**

See Decoration, underglaze. Unglazed paver tile. See Pavers.

**Unglazed quarry tile**

See Quarry tile.

**Unglazed tile**

A hard, dense tile of homogeneous composition throughout, deriving color and texture from the materials of which the body is made. The colors and characteristics of the tile are determined by the materials used in the body, the method of manufacture, and the thermal treatment. (ASTM C242)

**Urethane**

An elastomeric polymer with excellent chemical and water resistance. Single component (moisture cure) and 2-part (chemical cure) systems are available. Both types may be applied in a fluid state and cure (polymerize) after installation. Typical tile industry applications include sealants, caulks, waterproofing membranes, and high performance flexible adhesives.

**V****Vapor barrier**

Waterproof membrane placed under concrete floor slabs that are placed on grade.

**V-Cap Trim**

V-shaped trim tile used on the front edge of a countertop. The tile's top surface is gently curved upward at the front edge to prevent water from running onto the floor.

**Vellum glaze**

A semi-mat glaze having a satin-like appearance. (ASTM C242)

**Vertical broken joint**

Style of laying tile with each vertical row of tile offset for half its length.

**Vitreous**

0.5 percent to 3 percent water absorption.

**Vitreous (Vitrified)**

That degree of verification evidenced by low water absorption. (See also Impervious; Nonvitreous; Semivitreous.) (ASTM C242).

NOTE: The term vitreous generally signifies less than .5 percent absorption, except for floor and wall tile and low voltage electrical porcelain which are considered vitreous up to 3.0 percent water absorption.

**Vitreous slip**

A slip coating matured on a ceramic body, producing a vitrified surface. (ASTM C242)

**Vitreous tile**

Tile with water absorption of more than 0.5 percent, but not more than 3.0 percent. (ANSI A137.1-1980)

**Vitrification**

The progressive reduction in porosity of a ceramic composition as a result of heat treatment, or the process involved. (ASTM C242)

**Vitrification range**

The maturing range of a vitreous body, producing a vitrified surface. (ASTM C242)

**Void**

An unfilled space in a material of trapped air or other gas.

**W****Wainscot Tile**

The lower part of an interior wall when finished in tile.

**Wall tile**

A glazed tile with a body that is suitable for interior use and which is usually nonvitreous and is not required nor expected to withstand excessive impact.

**Warpage**

A concave or convex curvature of a tile so that the surface is not perfectly flat.

**Water absorption**

The ability to take up and retain water.

**Water-cement ratio**

The ratio of the amount of water, exclusive only of that absorbed by the aggregates, to the amount of cement in a concrete or mortar mixture; preferably stated as a decimal by weight.

**Water level**

The water level is a piece of clear plastic hose 10 mm to 13 mm in diameter and usually about 15,240 mm in length. It is filled with water, from which all air must be removed.

**Waterproof membrane**

A membrane, usually made of built-up roofing, to provide a positive waterproof floor over the substrate, which is to receive a tile installation using a wire reinforced mortar bed. (CTI)

**Wearing course**

A topping or surface treatment to increase the resistance of a concrete pavement or slab to abrasion.

**Weathering**

Changes in color, texture, strength, chemical composition or other properties of a natural or artificial material due to the action of the weather.

**Welded-wire fabric**

A series of longitudinal and transverse wires arranged substantially at right angles to each other and welded together at all points of intersection.

**Welded-wire fabric reinforcement**

Welded-wire fabric in either sheets or rolls, used to reinforce mortar and concrete.

**Well-graded aggregate**

Aggregate having a particle size distribution which will produce maximum density, i.e., minimum void space.

**Wet areas**

Tile surfaces that are either soaked, saturated or regularly and frequently subjected to moisture or liquids (usually water) such as gang showers, tub enclosures, showers, laundries, saunas, steam rooms, swimming pools, hot tubs and exterior areas.

**Wet pressing**

See Pressing, wet. Wet process. See Process, wet.

**Wetting**

The thorough impregnation of a material by a liquid. The more viscous a fluid, and the higher its surface tension, the more difficult it is for the liquid to "wet" materials. Certain additives, such as, water softeners, reduce surface tension or viscosity and improve wetting properties, allowing the material to be better absorbed.

**Wetting agent**

A substance capable of lowering the surface tension of liquids, facilitating the wetting of solid surfaces and permitting the penetration of liquids into the capillaries.

**Whiting**

Calcium carbonate powder of high purity. (ASTM C242)

**Wire mesh**

See Welded-wire fabric.

**Wood float**

The wood float is sometimes used in place of the flat trowel for floating mortar. It is good for smoothing small irregularities left on the mortar bed, working the surface of the mortar before troweling on the pure coat, or compacting floor and deck mortar.

**Workability**

The property of freshly mixed concrete or mortar which determines the ease and homogeneity with which it can be mixed, placed, compacted, and finished.

**Wrinkled sheets**

Pertaining to ceramic mosaics mounted on paper. Due primarily to rough handling in shipment.

**Y****Yellow ware**

A yellow semi-vitreous ware or an earthenware with a colorless clear glaze. (ASTM C242)

**Z****Zircon porcelain**

A vitreous ceramic whiteware for technical application in which zircon is the essential crystalline phase. (ASTM C242)

**Zircon whiteware**

Any ceramic whiteware in which zircon is the essential crystalline phase. (ASTM C242)

# Metric Conversion Guide

To convert inches to millimetres, multiply the number of inches by 25.4 to obtain millimetres. To convert feet to millimetres, multiply the number of feet by 304.88 to obtain millimetres. To convert millimetres to feet multiply the number of millimetres by .00328 to obtain feet.

For a reference only, some common (rounded nominal) industry metric conversions to the imperial equivalents follow:

| mm to inch conversion |                      |                      |                     |
|-----------------------|----------------------|----------------------|---------------------|
| 1 mm = 1/32 inch      | 19 mm = 3/4 inch     | 150 mm = 6 inches    | 600 mm = 24 inches  |
| 1.5 mm = 1/16 inch    | 22 mm = 7/8 inch     | 180 mm = 7 inches    | 1000 mm = 40 inches |
| 3 mm = 1/8 inch       | 25 mm = 1 inch       | 200 mm = 8 inches    | 1200 mm = 4 feet    |
| 5 mm = 3/16 inch      | 30 mm = 1-1/8 inches | 280 mm = 11 inches   | 2400 mm = 7.8 feet  |
| 6 mm = 1/4 inch       | 32 mm = 1-1/4 inches | 300 mm = 12 inches   | 2440 mm = 8 feet    |
| 8 mm = 5/16 inch      | 38 mm = 1-1/2 inches | 356 mm = 14 inches   | 3000 mm = 10 feet   |
| 10 mm = 3/8 inch      | 51 mm = 2 inches     | 380 mm = 15 inches   | 3600 mm = 12 feet   |
| 11 mm = 7/16 inch     | 75 mm = 3 inches     | 406 mm = 16 inches   | 4600 mm = 15 feet   |
| 13 mm = 1/2 inch      | 92 mm = 3.62 inches  | 480 mm = 19 inches   | 4900 mm = 16 feet   |
| 14 mm = 9/16 inch     | 100 mm = 4 inches    | 488 mm = 19.2 inches | 6100 mm = 20 feet   |
| 16 mm = 5/8 inch      | 125 mm = 5 inches    | 500 mm = 20 inches   | 9000 mm = 30 feet   |

| kg to lbs conversion |                 |                    |
|----------------------|-----------------|--------------------|
| 1 kg = 3 lbs         | 5.4 kg = 12 lbs | 135 kg = 298 lbs   |
| 2,27 kg = 5 lbs      | 40 kg = 90 lbs  | 136 kg = 300 lbs   |
| 4.5 kg = 10 lbs      | 45 kg = 99 lbs  | 727 kg = 1,600 lbs |

| MPa to PSI conversion |                     |                    |                     |
|-----------------------|---------------------|--------------------|---------------------|
| .27 MPa = 40 PSI      | 4.8 MPa = 700 PSI   | 17 MPa = 2,500 PSI | 69 MPa = 10,000 PSI |
| 1.3 MPa = 200 PSI     | 5.5 MPa = 800 PSI   | 21 MPa = 3,000 PSI | 48 MPa = 7,000 PSI  |
| 2.75 MPa = 400 PSI    | 6.8 MPa = 1,000 PSI | 24 MPa = 3,500 PSI |                     |
| 3.1 MPa = 450 PSI     | 10 MPa = 1,500 PSI  | 34 MPa = 5,000 PSI |                     |
| 4.1 MPa = 600 PSI     | 14 MPa = 2,000 PSI  | 62 MPa = 9,000 PSI |                     |

| kPa to psf conversion |                   |
|-----------------------|-------------------|
| .48 kPa = 10 psf      | 1.92 kPa = 40 psf |

| kg/m <sup>3</sup> to lb/ft <sup>3</sup> conversion |
|--|
| 1681 kg/m <sup>3</sup> = 105 lb/ft <sup>3</sup>    |

| kg/m <sup>3</sup> to cu. ft conversion      |
|---|
| 1842.12 kg/m <sup>3</sup> = 115 per cu. ft. |

| kg of force to lbs of force conversion         |
|--|
| 907 Kilograms of force = 2,000 pounds of force |

| m <sup>2</sup> to ft <sup>2</sup> conversion |
|--|
| 93 m <sup>2</sup> = 1,000 ft <sup>2</sup>    |

| N/mm <sup>2</sup> to PSI conversion |
|-------------------------------------|
| 13.78 N/mm <sup>2</sup> = 2,000 PSI |









**Head Office**

5250 Satellite Drive  
Unit 35  
Mississauga, Ontario  
L4W 5B8  
T: 905.660.9640  
800.201.8599  
F: 905.660.0513

**Western Office**

T: 604.294.6885  
F: 604.294.2406

**E-mail:** [association@ttmac.com](mailto:association@ttmac.com)  
[technicalinfo@ttmac.com](mailto:technicalinfo@ttmac.com)

**Web site:** [ttmac.com](http://ttmac.com)