



SUITABLE SUBSTRATES

- Suitable panel subfloors over wood joist at maximum of 406 mm o.c. where deflection under both dead and live loads conforms to local and national building codes.

MATERIALS

- TILE - Ceramic, mosaic, porcelain, quarry, pavers, agglomerate, precast terrazzo natural stone.
- BOND COAT - Latex-Portland cement mortars, modified epoxy emulsion mortars or 100% solids epoxy mortars.
- GROUT - Portland cement, latex-Portland cement or epoxy.

DETAIL A – THIN-SET ON PLYWOOD – Suitable Subfloor: Douglas Fir plywood, Canadian Softwood plywood, Poplar plywood, Construction sheathing or OSB. Joists to be spaced 406 mm o.c. Apply both layers of panel with top grain at right angles to joist, and with top layer staggered to give 50% overlap of sheets of sub-floor. Gap the top layer of plywood 6 mm between sheets. Underlayment: Only 16 mm or thicker Douglas Fir exterior-grade plywood Select Tight-faced, meeting CSA-0121. Attach underlayment with 30 mm screws placed 152 mm o.c. around perimeter and 203 mm o.c. throughout the body of the panel. Underlayment screws to go through the total thickness of the assembly but should not penetrate the joists or cross bridging/solid blocking. **Use sufficient bond coat to ensure minimum 80% contact.** Contact shall be evenly distributed to give full support of the tile. Slide tile firmly into position. Allow bond coat to cure. Force grout into full depth of joint, remove excess grout and clean.

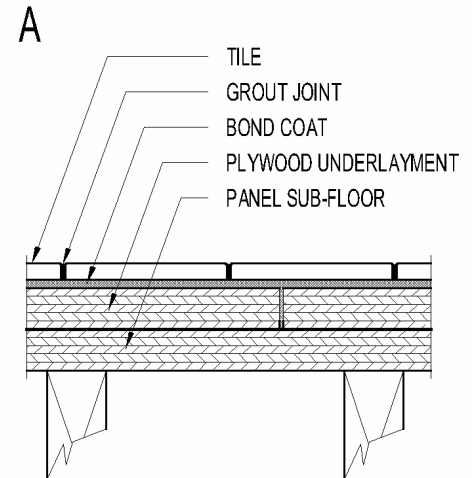

DETAIL B – THIN-SET ON BACKER UNIT/BOARD Suitable Subfloor: Douglas Fir plywood, Canadian Softwood plywood, Poplar plywood, Construction sheathing or OSB. Underlayment: Minimum 13 mm cementitious backer unit (CBU) or coated glass mat backer board or nominal 11 mm thick fibre-cement backer board meeting ASTM C1288-1999 bedded in latex-Portland cement mortar and gapped 3 mm. Fasten underlayment to subfloor with 30 mm galvanized screws 203 mm o.c. throughout the body of the panel. Do not counter sink screws for coated glass mat backer board. Treat joints as per manufacturer’s directions. Apply bond coat, filling gaps in underlayment. Apply tile to bond coat before bond coat skins over. **Use sufficient bond coat to ensure minimum 80% contact.** Contact shall be evenly distributed to give full support of the tile. Slide tile firmly into position. Allow bond coat to cure. Force grout into full depth of joint, remove excess grout and clean.

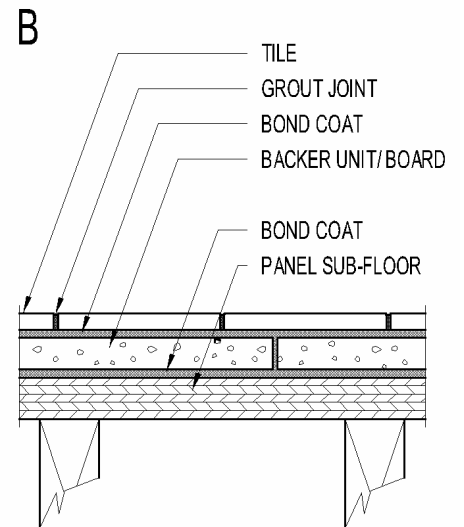

DETAIL C – MORTAR BED WITH CLEAVAGE MEMBRANE

Install polyethylene film, galvanized metal lath, 32 mm mortar bed (see Tile Guide Specification Section Mixes 2.5.3) and tile as per application directions of detail 314F-2006/2007. Finished tolerance of mortar bed not to exceed 6 mm in 3049 mm or 2 mm in 305 mm.

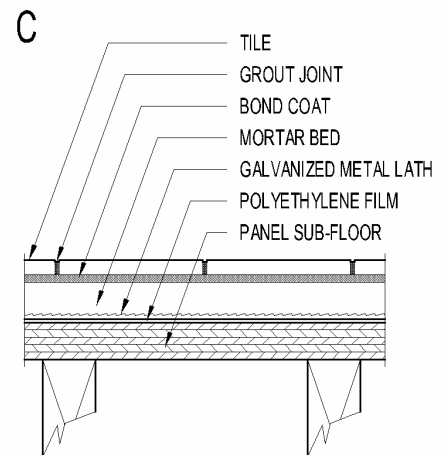

Continued next page

313F-2006/2007 DETAIL D – THIN-SET ON UNCOUPLING SYSTEM

Suitable Subfloor: Minimum 15 mm Douglas Fir plywood, Canadian Softwood plywood, Poplar plywood, Construction sheathing or OSB for joists spaced 406 mm o.c. For floor trusses or I-joists spaced 480 mm o.c., sub-floor minimum 20 mm meeting CSA as indicated above. For floor trusses or I-joists spaced 610 mm o.c. sub-floor minimum 20 mm with overlay of 10 mm minimum of plywood meeting CSA 0121 or O.S.B. meeting CSA 0437.0 or CSA 0325.0, with 3 mm gap between sheets. Underlayment screws to go through the total thickness of the assembly but should not penetrate the joists or cross bridging/solid blocking. Install uncoupling system to manufacturer's recommendations. **Use sufficient bond coat to ensure minimum 80% contact.** Contact shall be evenly distributed to give full support of the tile. Slide tile firmly into position. Allow bond coat to cure. Force grout into full depth of joint, remove excess grout and clean. Floor systems, including the framing system and subfloor panels, over which the tile will be installed shall be in conformance with the Canadian National Building Code 2005 and applicable local building codes taking into consideration anticipated live and dead loads. Uncoupling system to be placed over heating system, follow manufacturer's recommendations. For definition of uncoupling system see Glossary.

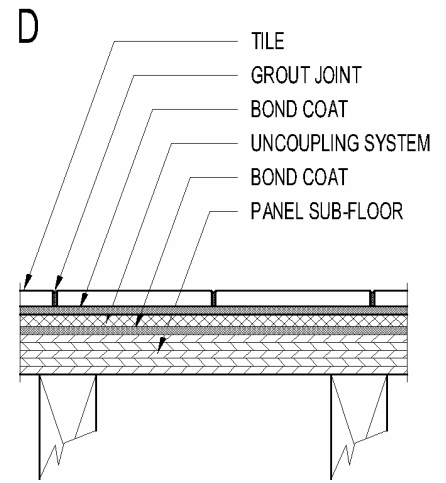

LIMITATIONS

- For use on interior floors in dry areas. For residential or light commercial use only.
- Waferboard, particleboard and similar products should not be used for subfloors or underlayment.

OTHER CONSIDERATIONS

- Local practice sometimes incorporates an expanded metal lath attached to the plywood. This is an acceptable method of installation, providing that two layers of plywood is used as per detail (A) and the material used to fill the metal lath is one of the bond coats listed above.
- Cross bridge floor joists but preferably solid blocking.
- Refer to Notes For The Professional and 301MJ-2006/2007.
- When using detail (C), recess floor joist with respect to adjacent areas to accommodate the thickness of the finished tile installation, or use transition strip where tile work abuts other floor coverings.
- For residential only a 25 mm mortar bed may be used. The sub-floor shall have a minimum thickness of 16 mm.
- For natural stone and some tile larger than 305 mm x 305 mm deflection must not exceed $L/720$ of span.